

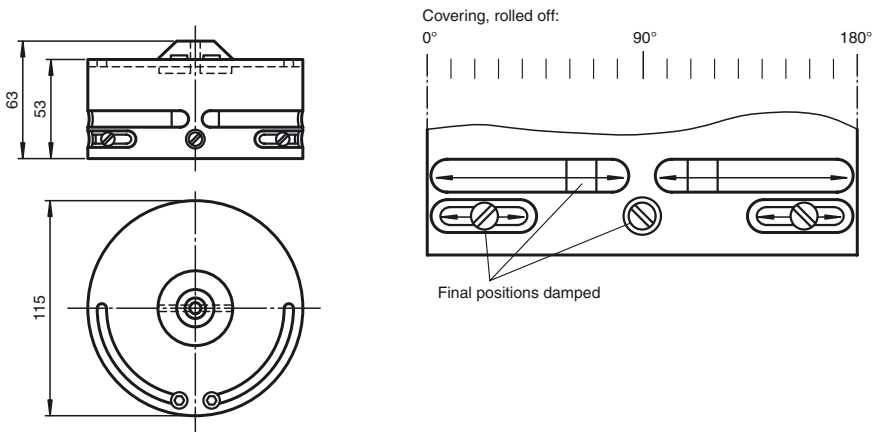

**Dimensions**



**Model Number**

**BT115B**

Activator for F31 series

**Features**

- 3-position indication option with F31 series double sensor
- Upper and lower damping levels are continuously adjustable
- One fixed actuating lug
- 2 x two 90° offset, 90° adjustable actuating lugs
- Suitable for right and left rotating drives

**Technical data**

**General specifications**

Ring diameter	≤ 105 mm
Spring ring height	≤ 5 mm

**Ambient conditions**

Ambient temperature	-25 ... 70 °C (-13 ... 158 °F)
---------------------	--------------------------------

**Mechanical specifications**

Shaft diameter	< 90 mm
Shaft height	30 mm and 50 mm
Mounting hole pattern	30 x 130 mm

**Material**

Housing	POM
Spacer disk	PA (2 units, 10 mm strong)
Mounting screw	for activator: 1.4305 / AISI 303 (1 x M6 x 35) for sensors - F31: 1.4305 / AISI 303 (4 items M5 x 16, (2 pieces M5 x 12)

Activation target	Stainless steel 1.4305 / AISI 303 (integrated)
-------------------	--

Release date: 2016-06-10 18:11 Date of issue: 2016-06-10 122900\_eng.xml