

Jul.1.2021 Copyright 2021 HIROSE ELECTRIC CO., LTD. All Rights Reserved.
 In case of consideration for using Automotive equipment / device which demand high reliability, kindly contact our sales window correspondents.

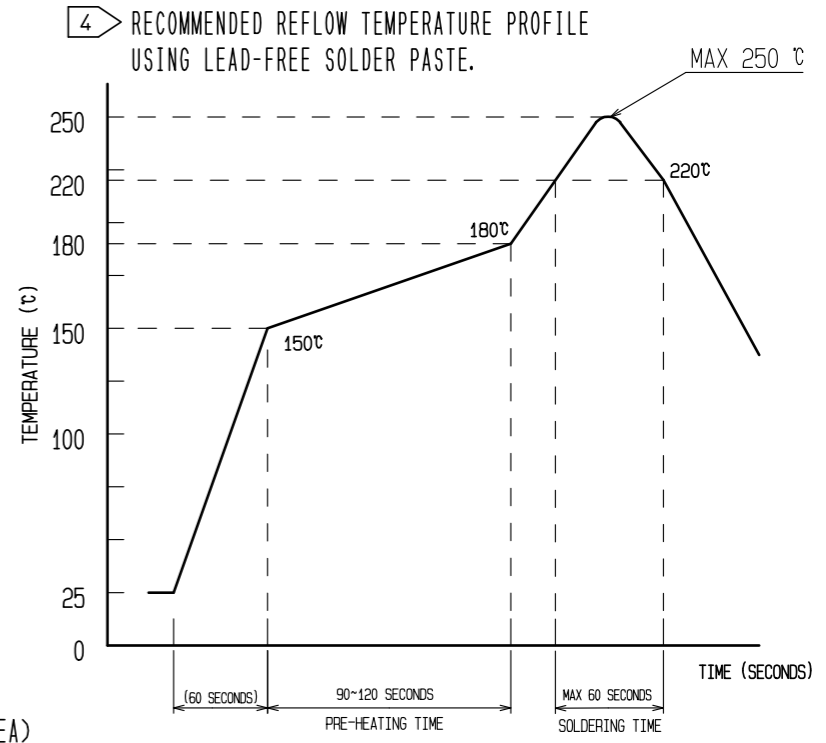

REFLOW METHOD: IR REFLOW
 NUMBER OF REFLOW CYCLES: 2 CYCLES MAX.
 1) REFLOW TIME
 DURATION ABOVE 220°C, 60 SEC MAX.
 (PEAK TEMPERATURE: 250°C MAX)
 2) PRE-HEAT TIME
 PRE-HEAT TEMPERATURE (MIN): 150°C
 PRE-HEAT TEMPERATURE (MAX): 180°C
 PRE-HEAT TIME: 90-120 SEC.

- NOTE 1. ALL LEAD CO-PLANARITY SHALL BE 0.08mm MAX.
 2 CONTACT PLATING SPECIFICATIONS
 CONTACT AREA : GOLD 0.05 μm MIN
 SMT LEAD : GOLD 0.05 μm MIN
 UNDER PLATING : NICKEL 1 μm MIN
 (SURFACE : SEALING)
 3 CAV No. AND HRS MARK EXIST IN THE INDICATED POSITION.

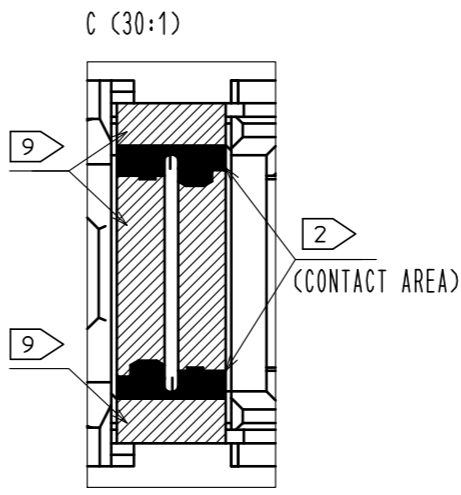
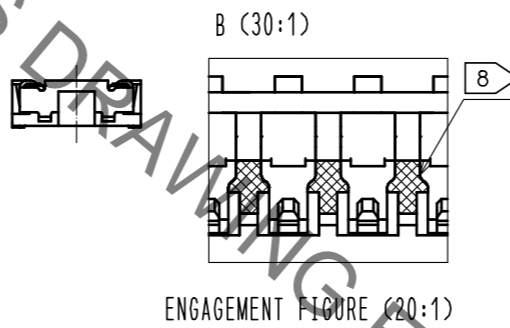
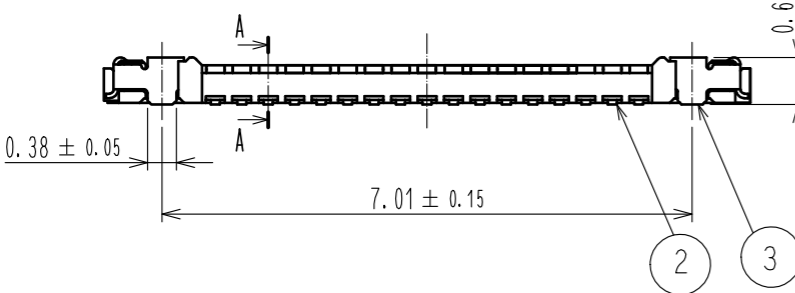
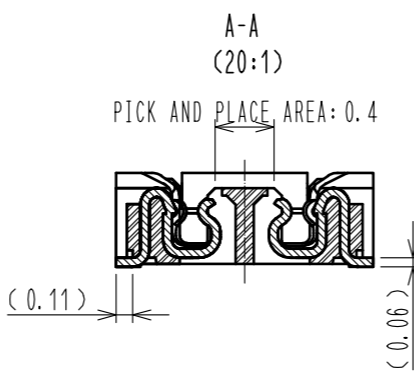
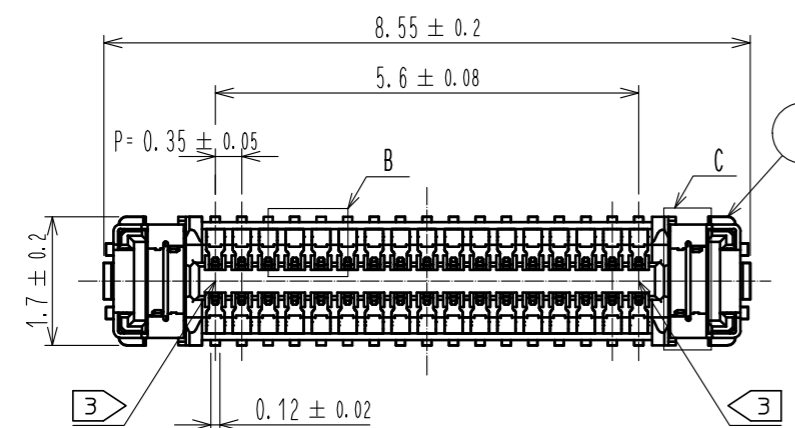
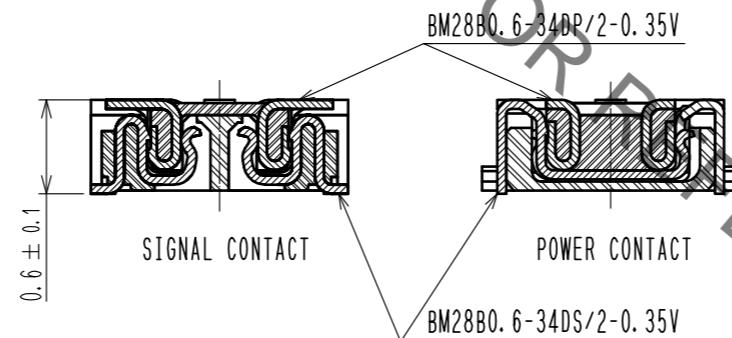

- 4 THIS TEMPERATURE PROFILE IS PER THE CONDITIONS SHOWN ABOVE. ADDITIONAL FACTORS, SUCH AS SOLDER PASTE TYPE, PCB SIZE AND OTHER MOUNTED COMPONENTS COULD AFFECT THE PROFILE. THEREFORE, A THOROUGH EVALUATION OF MOUNTING COONDITION IS REQUIRED PRIOR TO PRODUCTION. TEPERATURE IS MEASURED AT CONTACT LEAD.
 5. PLEASE CONTACT US IN CASE YOU WILL MAKE DIFFERENT SETTINGS FROM OUR RECOMMENDATION.
 6. THIS PRODUCT SATISFIES HALOGEN FREE REQUIREMENTS DEFINED AS 900ppm MAXIMUM CHLORINE, 900ppm MAXIMUM BROMINE, AND 1500ppm MAXIMUM TOTAL OF CHLORINE AND BROMINE.
 7. THIS PRODUCT COMPLY WITH RoHS.
 8 WELD LINE APPEARS IN THE INDICATED POSITION.
 9 NO GOLD PLATING IS ACCEPTABLE FOR THIS AREA.

◆ RECOMMENDED PCB LAYOUT

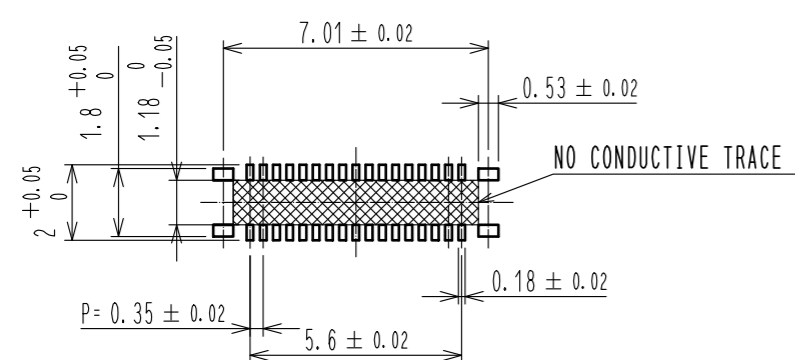

◆ RECOMMENDED METAL MASK DIMENSIONS
 METAL MASK THICKNESS : 80 μm

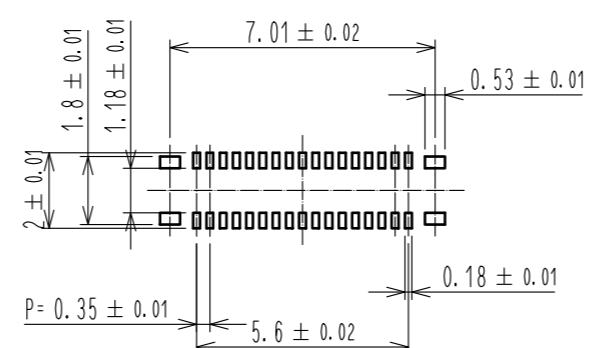

4	PS	CLEAR(EMBOSSED CARRIER TAPE)			
3	COPPER ALLOY	2	7	PS	CLEAR (REINFORCEMENT COLLAR)
2	COPPER ALLOY	2	6	PS	BLACK (PLASTIC REEL)
1	LCP	UL94 V-0, BLACK	5	POLYESTER	CLEAR (COVER TAPE)
NO.	MATERIAL	FINISH . REMARKS	NO.	MATERIAL	FINISH . REMARKS
UNITS mm		SCALE 10 : 1	COUNT	DESCRIPTION OF REVISIONS	
DESIGNED		CHECKED		DATE	
APPROVED : MO. ISHIDA 17.01.05			DRAWING NO. EDC-370835-51-01		
CHECED : TS. MIYAZAKI 17.01.05			PART NO. BM28B0.6-34DS/2-0.35V(51)		
DESIGNED : RT. SHIMIZU 16.12.29			CODE NO. CL673-5065-0-51		
DRAWN : RT. SHIMIZU 16.12.29			1/2		

Jul.1.2021 Copyright 2021 HIROSE ELECTRIC CO., LTD. All Rights Reserved.
 In case of consideration for using Automotive equipment / device which demand high reliability, kindly contact our sales window correspondents.

EMBOSSED CARRIER TAPE PACKAGING (5:1)

STYLE AND DIMENSION OF REEL (FREE)

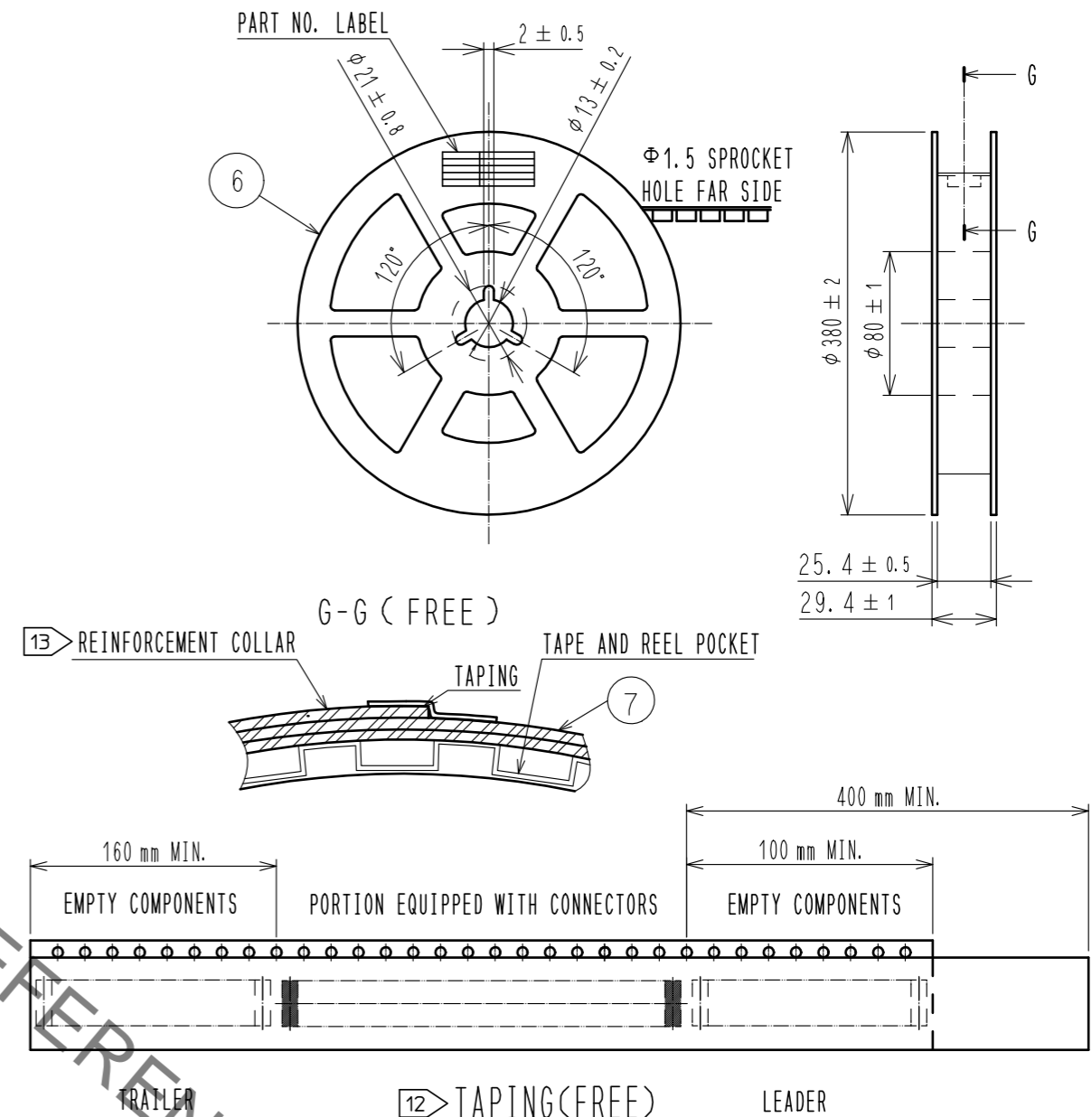
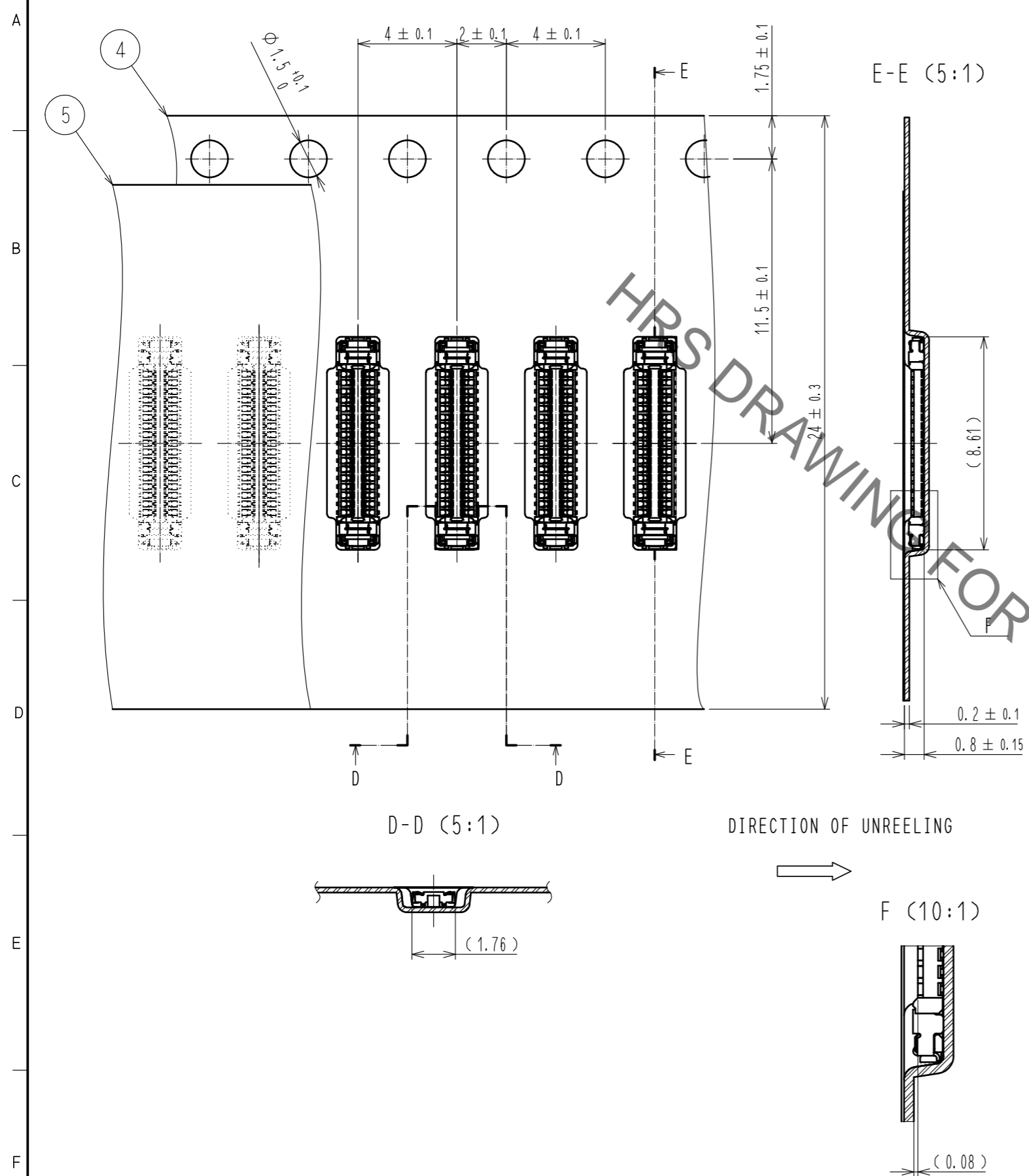

DETAIL OF PART NO. LABEL

製造年月日	** ** *
製品コード	CL0673-****-**
製品名	BM28B0.6-**
数量	20,000
納入者	ヒロセ電機(株)

DATA OF MANUFACTURED
 CODE NO.
 PART NO.
 QUANTITY
 SUPPLIER

- 10. PER REEL 20,000 CONNECTORS.
- 11. THE DIMENSIONS IN PARENTHESES ARE FOR REFERENCE.
- 12. REFER TO JIS C 0806, IEC 60286-3(PACKAGING OF COMPONENTS FOR AUTOMATIC HANDLING)
- 13. AFTER PACKAGING, ROLL 2 METERS OF THE REINFORCEMENT COLLAR TO OUTER CIRCUMFERENCE OF TAPE AND REEL POCKET. AND TAPE DOWN AT THE END THE COLLAR.

HRS	DRAWING NO.	EDC-370835-51-01
	PART NO.	BM28B0.6-34DS/2-0.35V(51)
	CODE NO.	CL673-5065-0-51
		△ 2/2