



Our Focus is in Plastics

Polymer Optics Ltd.

6 Kiln Ride, Wokingham,
Berks., RG40 3JL, England
Tel/Fax: +44 (0) 1189 893341
www.polymer-optics.co.uk

30mm Colour Mixer Reflector for SSC P5-II RGB LED - Part No. 232



- Designed for Seoul Semiconductor P5-II RGB LEDs
- Colour mixing chamber design provides uniform beam colour, which with the output reflector optic, provides a narrow colour mixed beam
- Narrow beam angle of 5 degrees half angle, 10 degrees FWHM (full width half maximum intensity)
- Optical efficiency of >60%
- Also available for other Seoul Semiconductor LED types

Precision moulded using POL's patent applied for metallised optical insert moulding technique with a polycarbonate frame construction for superior mechanical and thermal stability

Polymer Optics "Modular LED Optics"[®] design, based on a hexagonal format, allows maximum packing density and assembly flexibility. Arrays of Colour Mixer Reflector optics can be easily constructed to produce high power luminaire designs

The 232 Reflector Optic base is designed to mounts over the P5-II RGB LED package to align to the LED source and provides a colour mixed beam for collimation by the reflector optic.

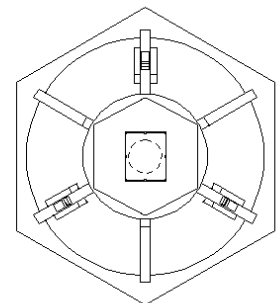
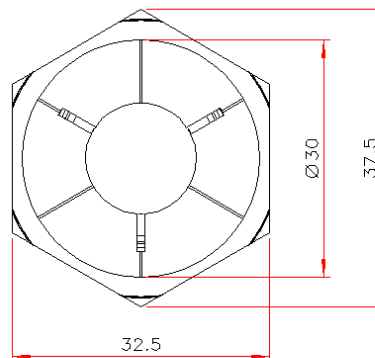
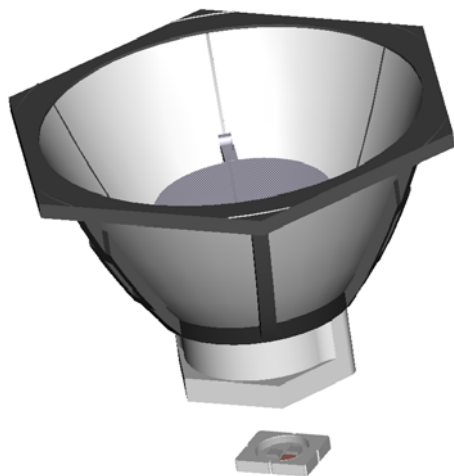

ORIENTATION OF BASE TO SSC P5-II PACKAGE

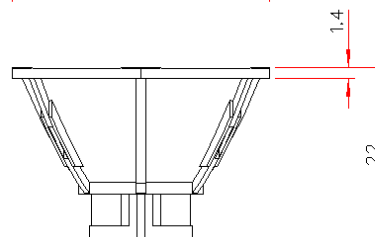

Typical dimensional tolerances to +/-0.2mm



Our Focus is in Plastics

Polymer Optics Ltd.

6 Kiln Ride, Wokingham,
Berks., RG40 3JL, England
Tel/Fax: +44 (0) 1189 893341
www.polymer-optics.co.uk

30mm Colour Mixer Reflector for SSC P5-II RGB LED - Part No. 232

The perfect colour mixing achieved with the POL 232 optic allows an infinite range of illumination colours to be produced with a constant and stable beam geometry.

An additional advantage is that the appearance of the emitted light from the POL 232 optic is a uniform mixed colour too, removing the usual visible spots of RGB seen in other colour mixing products.

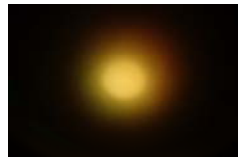
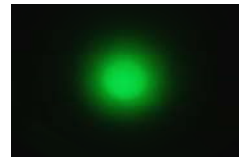
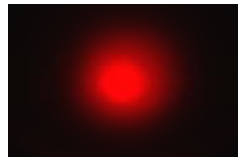
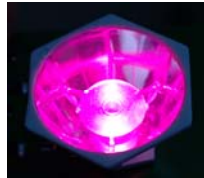

The POL 232 optic's narrow, high intensity beam is ideal for demanding applications, such as:

- ✓ Architectural spot lights
- ✓ Theatrical lights and follow-spots
- ✓ Forensic torches
- ✓ Medical lighting applications

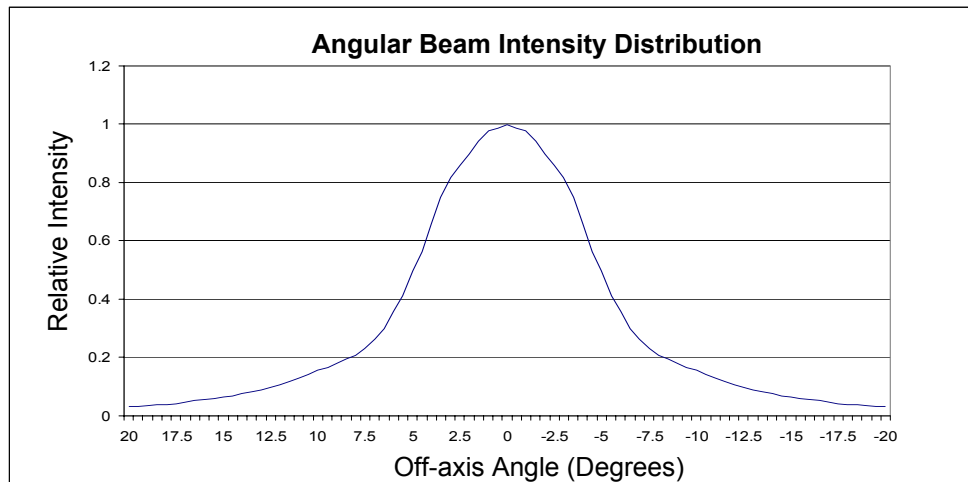

Performance values given are typical values and will vary dependant on LED binning, colour and drive profile