

## 18/36/72-Mbit Programmable FIFOs

### Features

- Memory organization
  - Industry's largest first in first out (FIFO) memory densities: 18-Mbit, 36-Mbit, and 72-Mbit
  - Selectable memory organization:  $\times 9$ ,  $\times 12$ ,  $\times 16$ ,  $\times 18$ ,  $\times 20$ ,  $\times 24$ ,  $\times 32$ ,  $\times 36$
- Up to 133-MHz clock operation
- Unidirectional operation
- Independent read and write ports
  - Supports simultaneous read and write operations
  - Reads and writes operate on independent clocks, upto a maximum ratio of two, enabling data buffering across clock domains.
  - Supports multiple I/O voltage standard: low voltage complementary metal oxide semiconductor (LVCMOS) 3.3 V and 1.8 V voltage standards.
- Input and output enable control for write mask and read skip operations
- Mark and retransmit: resets read pointer to user marked position
- Empty, full, half-full, and programmable almost-empty and almost-full status flags with configured offsets
- Flow-through mailbox register to send data from input to output port, bypassing the FIFO sequence
- Configure programmable flags and registers through serial or parallel modes
- Separate serial clock (SCLK) input for serial programming
- Master reset to clear entire FIFO
- Partial reset to clear data but retain programmable settings
- Joint test action group (JTAG) port provided for boundary scan function
- Industrial temperature range:  $-40\text{ }^{\circ}\text{C}$  to  $+85\text{ }^{\circ}\text{C}$

### Functional Description

The Cypress programmable FIFO family offers the industry's highest-density programmable FIFO memory device. It has independent read and write ports, which can be clocked up to 133 MHz. User can configure input and output bus sizes. The maximum bus size of 36 bits enables a maximum data throughput of 4.8 Gbps. The user-programmable registers enable user to configure the device operation as desired. The device also offers a simple and easy-to-use interface to reduce implementation and debugging efforts, improve time-to-market, and reduce engineering costs. This makes it an ideal memory choice for a wide range of applications including multiprocessor interfaces, video and image processing, networking and telecommunications, high-speed data acquisition, or any system that needs buffering at high speeds across different clock domains.

As implied by the name, the functionality of the FIFO is such that the data is read out of the read port in the same sequence in which it was written into the write port. If writes and inputs are enabled (WEN & IE), data on the write port gets written into the device at the rising edge of write clock. Enabling reads and outputs (REN & OE) fetches data on the read port at every rising edge of read clock. Both reads and writes can occur simultaneously at different speeds provided the ratio between read and write clock is in the range of 0.5 to 2. Appropriate flags are set whenever the FIFO is empty, almost-empty, half-full, almost-full or full.

The device also supports mark and retransmit of data, and a flow-through mailbox register.

All product features and specs are common to all densities (CYF0072V, CYF0036V, and CYF0018V). All descriptions are given assuming the 72Mbit (CYF0072V) device is operated in  $\times 36$  mode. They are valid for other densities (CYF0036V, and CYF0018V) and all port sizes  $\times 9$ ,  $\times 12$ ,  $\times 16$ ,  $\times 18$ ,  $\times 20$ ,  $\times 24$  and  $\times 32$  unless otherwise specified. The only difference will be in the input and output bus width. [Table 1 on page 7](#) shows the part of bus with valid data from D[35:0] and Q[35:0] in  $\times 9$ ,  $\times 12$ ,  $\times 16$ ,  $\times 18$ ,  $\times 20$ ,  $\times 24$ ,  $\times 32$  and  $\times 36$  modes.

For a complete list of related documentation, [click here](#).

**Errata:** For information on silicon errata, see [Errata](#) on page 31. Details include trigger conditions, devices affected and proposed workaround.

### Logic Block Diagram

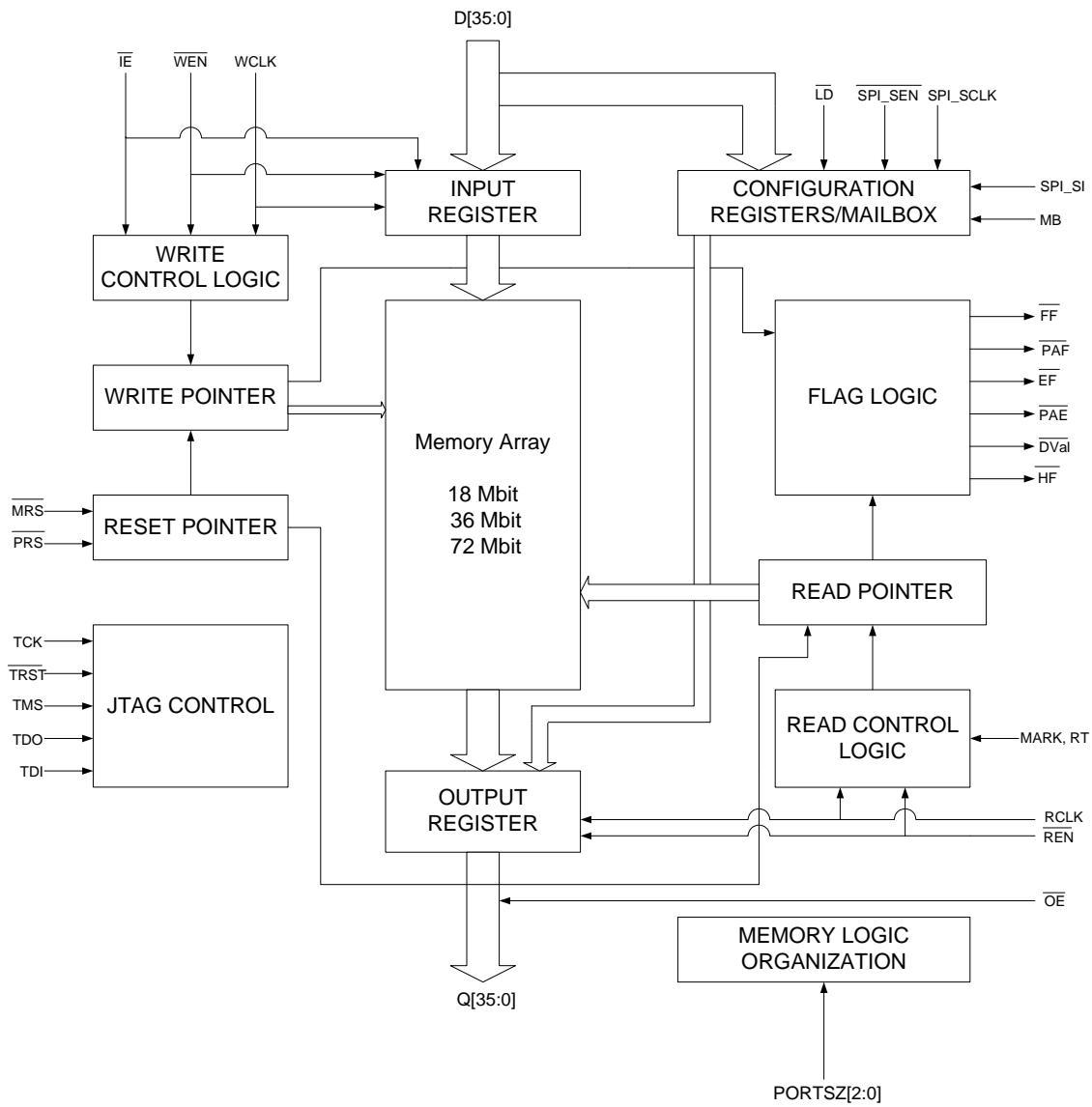

## Contents

<b>Pin Diagram for CYF0XXXVXXL [1]</b> .....	<b>4</b>	<b>Switching Characteristics</b> .....	<b>18</b>
<b>Pin Definitions</b> .....	<b>5</b>	<b>Switching Waveforms</b> .....	<b>19</b>
<b>Architecture</b> .....	<b>7</b>	<b>Ordering Information</b> .....	<b>28</b>
Reset Logic .....	7	Ordering Code Definitions .....	28
Selecting Word Sizes .....	7	<b>Package Diagram</b> .....	<b>29</b>
Memory Organization for Different Port Sizes .....	7	<b>Acronyms</b> .....	<b>30</b>
Data Valid Signal (DVal) .....	8	<b>Document Conventions</b> .....	<b>30</b>
Write Mask and Read Skip Operation .....	8	Units of Measure .....	30
Flow-through Mailbox Register .....	8	<b>Errata</b> .....	<b>31</b>
Flag Operation .....	8	Part Numbers Affected .....	31
Retransmit from Mark Operation .....	9	18-Mbit, 36-Mbit, and 72-Mbit Programmable FIFO	
Programming Flag Offsets and		Qualification Status .....	31
Configuration Registers .....	9	18-Mbit, 36-Mbit, and 72-Mbit Programmable FIFO	
Width Expansion Configuration .....	13	Errata Summary .....	31
Power Up .....	13	<b>Document History Page</b> .....	<b>33</b>
Read/Write Clock Requirements .....	13	<b>Sales, Solutions, and Legal Information</b> .....	<b>36</b>
JTAG Operation .....	14	Worldwide Sales and Design Support .....	36
<b>Maximum Ratings</b> .....	<b>15</b>	Products .....	36
<b>Operating Range</b> .....	<b>15</b>	PSoC® Solutions .....	36
<b>Recommended DC Operating Conditions</b> .....	<b>15</b>	Cypress Developer Community .....	36
<b>Electrical Characteristics</b> .....	<b>15</b>	Technical Support .....	36
<b>I/O Characteristics</b> .....	<b>16</b>		
<b>Latency Table</b> .....	<b>16</b>		

**Pin Diagram for CYF0XXXVXXL** <sup>[1]</sup>

**Figure 1. 209-ball FBGA pinout (Top View)**

	1	2	3	4	5	6	7	8	9	10	11
A	$\overline{\text{FF}}$	D0	D1	DNU	PORTSZ0	PORTSZ1	DNU	DNU	RT	Q0	Q1
B	$\overline{\text{EF}}$	D2	D3	DNU	DNU	PORTSZ2	DNU	DNU	$\overline{\text{REN}}$	Q2	Q3
C	D4	D5	$\overline{\text{WEN}}$	DNU	V <sub>CC1</sub>	DNU	V <sub>CC1</sub>	DNU	RCLK	Q4	Q5
D	D6	D7	V <sub>SS</sub>	V <sub>CC1</sub>	DNU	$\overline{\text{LD}}$	DNU	V <sub>CC1</sub>	V <sub>SS</sub>	Q6	Q7
E	D8	D9	V <sub>CC2</sub>	V <sub>CC2</sub>	V <sub>CCIO</sub>	V <sub>CCIO</sub>	V <sub>CCIO</sub>	V <sub>CC2</sub>	V <sub>CC2</sub>	Q8	Q9
F	D10	D11	V <sub>SS</sub>	V <sub>SS</sub>	V <sub>SS</sub>	DNU	V <sub>SS</sub>	V <sub>SS</sub>	V <sub>SS</sub>	Q10	Q11
G	D12	D13	V <sub>CC2</sub>	V <sub>CC2</sub>	V <sub>CCIO</sub>	V <sub>CC1</sub>	V <sub>CCIO</sub>	V <sub>CC2</sub>	V <sub>CC2</sub>	Q12	Q13
H	D14	D15	V <sub>SS</sub>	V <sub>SS</sub>	V <sub>SS</sub>	V <sub>CC1</sub>	V <sub>SS</sub>	V <sub>SS</sub>	V <sub>SS</sub>	Q14	Q15
J	D16	D17	V <sub>CC2</sub>	V <sub>CC2</sub>	V <sub>CCIO</sub>	V <sub>CC1</sub>	V <sub>CCIO</sub>	V <sub>CC2</sub>	V <sub>CC2</sub>	Q16	Q17
K	DNU	DNU	WCLK	DNU	V <sub>SS</sub>	$\overline{\text{IE}}$	V <sub>SS</sub>	DNU	V <sub>CCIO</sub>	V <sub>CCIO</sub>	V <sub>CCIO</sub>
L	D18	D19	V <sub>CC2</sub>	V <sub>CC2</sub>	V <sub>CCIO</sub>	V <sub>CC1</sub>	V <sub>CCIO</sub>	V <sub>CC2</sub>	V <sub>CC2</sub>	Q18	Q19
M	D20	D21	V <sub>SS</sub>	V <sub>SS</sub>	V <sub>SS</sub>	V <sub>CC1</sub>	V <sub>SS</sub>	V <sub>SS</sub>	V <sub>SS</sub>	Q20	Q21
N	D22	D23	V <sub>CC2</sub>	V <sub>CC2</sub>	V <sub>CCIO</sub>	V <sub>CC1</sub>	V <sub>CCIO</sub>	V <sub>CC2</sub>	V <sub>CC2</sub>	Q22	Q23
P	D24	D25	V <sub>SS</sub>	V <sub>SS</sub>	V <sub>SS</sub>	$\overline{\text{SPI\_SEN}}$	V <sub>SS</sub>	V <sub>SS</sub>	V <sub>SS</sub>	Q24	Q25
R	D26	D27	V <sub>CC2</sub>	V <sub>CC2</sub>	V <sub>CCIO</sub>	V <sub>CCIO</sub>	V <sub>CCIO</sub>	V <sub>CC2</sub>	V <sub>CC2</sub>	Q26	Q27
T	D28	D29	V <sub>SS</sub>	V <sub>CC1</sub>	V <sub>CC1</sub>	SPI_SI	V <sub>CC1</sub>	V <sub>CC1</sub>	V <sub>SS</sub>	Q28	Q29
U	$\overline{\text{DVal}}$	DNU	D30	D31	$\overline{\text{PRS}}$	DNU <sup>[2]</sup>	SPI_SCLK	V <sub>REF</sub>	$\overline{\text{OE}}$	Q30	Q31
V	$\overline{\text{PAF}}$	$\overline{\text{PAE}}$	D32	D33	DNU	$\overline{\text{MRS}}$	MB	DNU	MARK	Q32	Q33
W	TDO	$\overline{\text{HF}}$	D34	D35	TDI	$\overline{\text{TRST}}$	TMS	TCK	DNU	Q34	Q35

**Notes**

1. Pin Diagram for 18-Mbit, 36-Mbit & 72-Mbit; 1.8V & 3.3V IO voltage options.
2. This pin should be tied to V<sub>SS</sub> preferably or can be left floating to ensure normal operation.

## Pin Definitions

Pin Name	I/O	Pin Description
$\overline{\text{MRS}}$	Input	Master reset: $\overline{\text{MRS}}$ initializes the internal read and write pointers to zero, resets all flags and sets the output register to all zeroes. During Master Reset, the configuration registers are set to default values.
$\overline{\text{PRS}}$	Input	Partial reset: $\overline{\text{PRS}}$ initializes the internal read and write pointers to zero, resets all flags and sets the output register to all zeroes. During Partial Reset, the configuration register settings are retained.
PORTSZ [2:0]	Input	Port word size select: Port word width select pins (common for read and write ports).
WCLK	Input	Write clock: The rising edge clocks data into the FIFO when writes are enabled ( $\overline{\text{WEN}}$ asserted). Data is written into the FIFO memory when $\overline{\text{LD}}$ is high and into configuration registers when $\overline{\text{LD}}$ is low.
$\overline{\text{LD}}$	Input	Load: When $\overline{\text{LD}}$ is LOW, D[7:0] (Q[7:0]) are written (read) into (from) the configuration registers. When $\overline{\text{LD}}$ is HIGH, D[35:0] (Q[35:0]) are written (read) into (from) the FIFO memory.
$\overline{\text{WEN}}$	Input	Write enable: Control signal to enable writes to the device. When $\overline{\text{WEN}}$ is low data present on the inputs is written to the FIFO memory or configuration registers on every rising edge of WCLK.
$\overline{\text{IE}}$	Input	Input enable: $\overline{\text{IE}}$ is the data input enable signal that controls the enabling and disabling of the 36-bit data input pins. If it is enabled, data on the D[35:0] pins is written into the FIFO. The internal write address pointer is always incremented at rising edge of WCLK if WEN is enabled, regardless of the $\overline{\text{IE}}$ level. This is used for 'write masking' or incrementing the write pointer without writing into a location.
D[35:0]	Input	Data inputs: Data inputs for a 36-bit bus.
RCLK	Input	Read clock: The rising edge initiates a read from the FIFO when reads are enabled ( $\overline{\text{REN}}$ asserted). Data is read from the FIFO memory when $\overline{\text{LD}}$ is high & from the configuration registers if $\overline{\text{LD}}$ is low.
$\overline{\text{REN}}$	Input	Read enable: Control signal to enable reads from the device. When $\overline{\text{REN}}$ is low data is read from the FIFO memory or configuration registers on every rising edge of RCLK.
$\overline{\text{OE}}$	Input	Output enable: When $\overline{\text{OE}}$ is LOW, FIFO data outputs are enabled; when $\overline{\text{OE}}$ is HIGH, the FIFO's outputs are in High Z (high impedance) state.
Q[35:0]	Output	Data outputs: Data outputs for a 36-bit bus.
$\overline{\text{DVal}}$	Output	Data valid: Active low data valid signal to indicate valid data on Q[35:0].
MARK	Input	Mark for retransmit: When this pin is asserted the memory location corresponding to the data present on the output bus is marked. Any subsequent retransmit operation resets the read pointer to this location.
RT	Input	Retransmit: A HIGH pulse on RT resets the internal read pointer to a physical location of the FIFO which is marked by the user (using MARK pin). With every valid read cycle after retransmit, previously accessed data is read until the FIFO is empty.
MB	Input	Mailbox: When asserted the reads and writes happen to flow-through mailbox register.
$\overline{\text{EF}}$	Output	Empty flag: When $\overline{\text{EF}}$ is LOW, the FIFO is empty. $\overline{\text{EF}}$ is synchronized to RCLK.
$\overline{\text{PAE}}$	Output	Programmable almost-empty: When $\overline{\text{PAE}}$ is LOW, the FIFO is almost empty based on the almost-empty offset value programmed into the FIFO. It is synchronized to RCLK.
$\overline{\text{HF}}$	Output	Half-full flag: When $\overline{\text{HF}}$ is LOW, half of the FIFO is full. $\overline{\text{HF}}$ is synchronized to WCLK.
$\overline{\text{PAF}}$	Output	Programmable almost-full: When $\overline{\text{PAF}}$ is LOW, the FIFO is almost full based on the almost-full offset value programmed into the FIFO. It is synchronized to WCLK.
$\overline{\text{FF}}$	Output	Full flag: When $\overline{\text{FF}}$ is LOW, the FIFO is full. $\overline{\text{FF}}$ is synchronized to WCLK.
SPI_SCLK	Input	Serial clock: A rising edge on SPI_SCLK clocks the serial data present on the SPI_SI input into the offset registers if SPI_SEN is enabled.
SPI_SI	Input	Serial input: Serial input data in SPI mode.
$\overline{\text{SPI_SEN}}$	Input	Serial enable: Enables serial loading of programmable flag offsets and configuration registers.
TCK	Input	Test clock (TCK) pin for JTAG.

**Pin Definitions** (continued)

Pin Name	I/O	Pin Description
TRST	Input	Reset pin for JTAG.
TMS	Input	Test mode select (TMS) pin for JTAG.
TDI	Input	Test data in (TDI) pin for JTAG.
TDO	Output	Test data out (TDO) pin for JTAG.
V <sub>REF</sub>	Input Reference	Reference voltage: Reference voltage (regardless of I/O standard used)
V <sub>CC1</sub>	Power Supply	Core voltage supply 1: 1.8 V supply voltage
V <sub>CC2</sub>	Power Supply	Core voltage supply 2: 1.5 V supply voltage
V <sub>CCIO</sub>	Power Supply	Supply for I/Os
V <sub>SS</sub>	Ground	Ground
DNU	–	Do not use: These pins need to be left floating.

## Architecture

The CYF0072V, CYF0036V, and CYF0018V are memory arrays of 72-Mbit, 36-Mbit, and 18-Mbit respectively. The memory organization is user configurable and word sizes can be selected as  $\times 9$ ,  $\times 12$ ,  $\times 16$ ,  $\times 18$ ,  $\times 20$ ,  $\times 24$ ,  $\times 32$ , or  $\times 36$ . The logic blocks to implement the FIFO functionality and the associated features are built around these memory arrays.

The input and output data buses have a maximum width of 36 bits. The input data bus goes to an input register and the data flow from the input register to the memory is controlled by the write control logic. The inputs to the write logic block are  $\overline{WCLK}$ ,  $\overline{WEN}$  and  $\overline{IE}$ . When the writes are enabled through  $\overline{WEN}$  and if the inputs are enabled by  $\overline{IE}$ , then the data on the input bus is written into the memory array at the rising edge of  $\overline{WCLK}$ . This also increments the write pointer. Enabling writes but disabling the data input pins through  $\overline{IE}$  only increments the write pointer without doing any writes or altering the contents of the memory location.

Similarly, the output register is connected to the data output bus. Transfer of contents from the memory to the output register is controlled by the read control logic. The inputs to the read control logic include  $\overline{RCLK}$ ,  $\overline{REN}$ ,  $\overline{OE}$ ,  $\overline{RT}$  and  $\overline{MARK}$ . When reads are enabled by  $\overline{REN}$  and outputs are enabled using  $\overline{OE}$ , the data from the memory pointed by the read pointer is transferred to the output data bus at the rising edge of  $\overline{RCLK}$  along with active low  $\overline{DVal}$ . If the outputs are disabled but the reads enabled, the outputs are in high impedance state, but internally the read pointer is incremented.

During write operation, the number of writes performed is always an even number (i.e., minimum write burst length is two and number of writes always a multiple of two). Whereas during read operation, the number of reads performed can be even or odd (i.e., minimum read burst length is one).

The  $\overline{MARK}$  signal is used to 'mark' the location from which data is retransmitted when requested and  $\overline{RT}$  is asserted to retransmit the data from the marked location.

## Reset Logic

The FIFO can be reset in two ways: Master Reset ( $\overline{MRS}$ ) and Partial Reset ( $\overline{PRS}$ ). The  $\overline{MRS}$  initializes the read and write pointers to zero and sets the output register to all zeroes. It also resets all flags & the configuration registers to their default values. The word size is configured through pins; values of the three  $\overline{PORTSZ}$  pins are latched during  $\overline{MRS}$ . A Master Reset is required after power-up before accessing the FIFO.

$\overline{PRS}$  resets the read pointer, write pointer and mark location to the first physical location in the memory array. It also resets all flags to their default values.  $\overline{PRS}$  does not affect the programmed configuration register values. Any changes to configuration registers during device operation mandates a  $\overline{PRS}$  cycle to guarantee accurate flag operation.

## Selecting Word Sizes

The word sizes are configured based on the logic levels on the  $\overline{PORTSZ}$  pins during the master reset ( $\overline{MRS}$ ) cycle only (latched on low to high edge). The port size cannot be changed during normal mode of operation and these pins are ignored. Table 1. explains the pins of  $D[35:0]$  and  $Q[35:0]$  that will have valid data in modes where the word size is less than  $\times 36$ . If word size is less than  $\times 36$ , the unused output pins are tri-stated by the device and unused input pins will be ignored by the internal logic. The pins with valid data input  $D[N:0]$  and output  $Q[N:0]$  is given in Table 1.

## Memory Organization for Different Port Sizes

The 72-Mbit memory has different organization for different port sizes. Table 1 shows the depth of the FIFO for all port sizes.

Note that for all port sizes, four to eight locations are not available for writing the data and are used to safeguard against false synchronization of empty and full flags.

**Table 1. Word Size Selection**

$\overline{PORTSZ}[2:0]$	Word Size	FIFO Depth <sup>[3]</sup>	Memory Size <sup>[3]</sup>	Active Input Data Pins $D[N:0]$	Active Output Data Pins $Q[N:0]$
000	$\times 9$	8 Meg	72-Mbit	$D[8:0]$	$Q[8:0]$
001	$\times 12$	4 Meg	48-Mbit	$D[11:0]$	$Q[11:0]$
010	$\times 16$	4 Meg	64-Mbit	$D[15:0]$	$Q[15:0]$
011	$\times 18$	4 Meg	72-Mbit	$D[17:0]$	$Q[17:0]$
100	$\times 20$	2 Meg	40-Mbit	$D[19:0]$	$Q[19:0]$
101	$\times 24$	2 Meg	48-Mbit	$D[23:0]$	$Q[23:0]$
110	$\times 32$	2 Meg	64-Mbit	$D[31:0]$	$Q[31:0]$
111	$\times 36$	2 Meg	72-Mbit	$D[35:0]$	$Q[35:0]$

**Note**

3. For all port sizes, four to eight locations are not available for writing the data.



## Data Valid Signal ( $\overline{\text{DVal}}$ )

Data valid ( $\overline{\text{DVal}}$ ) is an active low signal, synchronized to RCLK and is provided to check for valid data on the output bus. When a read operation is performed, the  $\overline{\text{DVal}}$  signal goes low along with output data. This helps user to capture the data without keeping track of REN to data output latency. This signal also helps when write and read operations are performed continuously at different frequencies by indicating when valid data is available at the output port Q[35:0].

## Write Mask and Read Skip Operation

As mentioned in [Architecture on page 7](#), enabling writes but disabling the inputs (IE HIGH) increments the write pointer without doing any write operations or altering the contents of the location.

This feature is called Write Mask and allows user to move the write pointer without actually writing to the locations. This “write masking” ability is useful in some video applications such as Picture In Picture (PIP).

Similarly, during a read operation, if the outputs are disabled by keeping the  $\overline{\text{OE}}$  high, the read data does not appear on the output bus; however, the read pointer is incremented. This feature is referred to as a Read Skip Operation.

## Flow-through Mailbox Register

This feature transfers data from input to output directly bypassing the FIFO sequence. When MB signal is asserted the data present in D[35:0] will be available at Q[35:0] after two WCLK cycles. Normal read and write operations are not allowed during flow-through mailbox operation. Before starting Flow-through mailbox operation FIFO read should be completed to make data valid  $\overline{\text{DVal}}$  high in order to avoid data loss from FIFO. The width of flow-through mailbox register always corresponds to port size.

## Flag Operation

This device provides five flag pins to indicate the condition of the FIFO.

### Full Flag

The Full Flag ( $\overline{\text{FF}}$ ) operates on double word (burst length of two) boundaries and goes LOW when the device is full. Write operations are inhibited whenever  $\overline{\text{FF}}$  is LOW regardless of the state of  $\overline{\text{WEN}}$ .  $\overline{\text{FF}}$  is synchronized to WCLK, that is, it is exclusively updated by each rising edge of WCLK. The worst

case assertion latency for Full Flag is four. As the user cannot know that the FIFO is full for four clock cycles, it is possible that user continues writing data during this time. In this case, the four data words written will be stored to prevent data loss and these words have to be read back in order for full flag to get de-asserted. The minimum number of reads required to de-assert full-flag is two and the maximum number of reads required to de-assert full flag is six. The assertion and de-assertion of Full flag with associated latencies is explained in Latency Table on page 14.

### Half-Full Flag

The Half-Full ( $\overline{\text{HF}}$ ) flag goes LOW when half of the memory array is written.  $\overline{\text{HF}}$  is synchronized to WCLK. The assertion and de-assertion of Half-Full flag with associated latencies is explained in [Latency Table on page 16](#).

### Empty Flag

The Empty Flag ( $\overline{\text{EF}}$ ) deassertion depends on burst writes and goes LOW when the device is empty. Read operations are inhibited whenever  $\overline{\text{EF}}$  is LOW, regardless of the state of  $\overline{\text{REN}}$ .  $\overline{\text{EF}}$  is synchronized to RCLK, that is, it is exclusively updated by each rising edge of RCLK. The assertion and de-assertion of Empty flag with associated latencies is explained in [Latency Table on page 16](#).

### Programmable Almost-Empty and Almost-Full Flags

The CYF0072V includes programmable Almost-Empty and Almost-Full flags. Each flag operates on word boundaries and is programmed (see [Programming Flag Offsets and Configuration Registers on page 9](#)) a specific distance from the corresponding boundary flags (Empty or Full). (offset can range from 16 to 1023) When the FIFO contains the number of words for which the flags are programmed, the  $\overline{\text{PAF}}$  or  $\overline{\text{PAE}}$  is asserted, signifying that the FIFO is either almost-full or almost-empty. The default flag offset for both  $\overline{\text{PAE}}$  and  $\overline{\text{PAF}}$  is 127 words. These programmable flag boundaries have thresholds associated with them. [Table 2](#) gives the assertion and de-assertion conditions for  $\overline{\text{PAE}}$  &  $\overline{\text{PAF}}$  flags based on these thresholds assuming default offset values.

The  $\overline{\text{PAF}}$  flag signal transition is caused by the rising edge of WCLK and the  $\overline{\text{PAE}}$  flag transition is caused by the rising edge of RCLK. The assertion and de-assertion of these flags with associated latencies is explained in [Latency Table on page 16](#).

**Table 2. Programmable Flag Assertion/De-assertion Thresholds**

Operation	$\overline{\text{PAE}}$ offset	Number of FIFO words - $\overline{\text{PAE}}$	$\overline{\text{PAF}}$ offset	Number of FIFO words - $\overline{\text{PAF}}$
Assertion	127	# FIFO words $\leq$ (PAE offset + 2) i.e. # FIFO words $\leq$ 129	127	# FIFO words $\geq$ FIFO depth - (offset + 1) i.e. # FIFO words $\geq$ 2M - 128
Deassertion	127	# FIFO words $>$ (offset) i.e. # FIFO words $>$ 127	127	# FIFO words $<$ FIFO depth - (offset) i.e. # FIFO words $<$ 2M - 127



## Retransmit from Mark Operation

The retransmit feature is useful for transferring packets of data repeatedly. It enables the receipt of data to be acknowledged by the receiver and retransmitted if necessary. Initiation of a retransmit operation (using RT pin) resets the internal read pointer to a physical location of the FIFO that is marked by the user (using the MARK pin). With every valid read cycle after retransmit, data is read out starting from the marked location and the read pointer is incremented until the FIFO is empty. Data written to FIFO after initiation of a retransmit operation are also transmitted. The full depth of the FIFO can be repeatedly retransmitted.

Flags are governed by the relative locations of the read and write pointers and are updated during a retransmit cycle. Refer to the latency table for the associated flag update latencies after initiation of a retransmit cycle<sup>[4]</sup>.

Asserting RT initiates a retransmit operation. The retransmit feature can be used when two or more data words have been written to the FIFO. When the MARK pin is asserted, the memory location corresponding to the data present on the output bus is marked. A mark operation is mandated prior to initiating a Retransmit operation.

A retransmit operation should not be initiated when reads or writes are in progress. User should wait for four RCLK cycles after disabling reads before RT is asserted to ensure that the reads are completed.

On initiation of RT the 'marked' location becomes the new Full Boundary. If user continues to write the data after initiation of a retransmit operation,  $\overline{FF}$  will be asserted when this boundary is reached i.e.  $\overline{FF}$  is asserted once the write pointer reaches the marked location. This prevents overwriting and data-loss. During RT reads the full boundary remains frozen to the marked location and is released when the FIFO becomes empty. i.e.  $\overline{FF}$  remains LOW until the entire FIFO is read. Full flag is released

$\overline{LFF\_RELEASE}$  clocks after the  $\overline{EF}$  is asserted. Full boundary is also released on a reset operation (MRS or PRS)<sup>[4]</sup>.

Refer to [Latency Table on page 16](#) for more details.

## Programming Flag Offsets and Configuration Registers

The CYF0072V has ten 8-bit user configurable registers. These registers contain the almost-full (M) and almost-empty (N) offset values which decide when the PAF and PAE flags are asserted.

These registers can be programmed in one of two ways: serial loading or parallel loading method. The loading method is selected using the SPI\_SEN (Serial Enable) pin. A low on the SPI\_SEN selects the serial method for writing into the registers. For serial programming, there is a separate SCLK and a Serial Input (SI). In parallel mode, a LOW on the load (LD) pin causes the write and read operation to these registers. The write and read operation happens from the first location (0x1) to the last location (0xA) in a sequence. If LD is HIGH, the writes occur to the FIFO.

Register values can be read through the parallel output port regardless of the programming mode selected (serial or parallel). Register values cannot be read serially. The registers may be programmed (and reprogrammed) any time after master reset, regardless of whether serial or parallel programming is selected. Any changes to configuration registers during device operation mandates a PRS cycle to guarantee accurate flag operation.

See [Table 4 on page 11](#) and [Table 5 on page 12](#) for access to configuration registers in serial and parallel modes.

In parallel mode, the read and write operations loop back when the maximum address location of the configuration registers is reached. Simultaneous read and write operations should be avoided on the configuration registers. Any change in configuration registers will take effect after eight write clock cycles (WCLK) cycles.

### Note

4. **Errata:** Refer to [Errata](#) on page 31 for details on flag operation and full boundary freezing during Mark and Retransmit operation.

**Table 3. Configuration Registers**

ADDR	Configuration Register	Default	Bit [7]	Bit [6]	Bit [5]	Bit [4]	Bit [3]	Bit [2]	Bit [1]	Bit [0]
0x1	Reserved	0x00	X	X	X	X	X	X	X	X
0x2	Reserved	0x00	X	X	X	X	X	X	X	X
0x3	Reserved	0x00	X	X	X	X	X	X	X	X
0x4	Almost-Empty Flag generation address - (LSB) (N)	0x7F	D7	D6	D5	D4	D3	D2	D1	D0
0x5	Almost-Empty Flag generation address - (MSB) (N)	0x00	X	X	X	X	X	X	D9	D8
0x6	Reserved	0x00	X	X	X	X	X	X	X	X
0x7	Almost-Full Flag generation address - (LSB) (M)	0x7F	D7	D6	D5	D4	D3	D2	D1	D0
0x8	Almost-Full Flag generation address - (MSB) (M)	0x00	X	X	X	X	X	X	D9	D8
0x9	Reserved	0x00	X	X	X	X	X	X	X	X
0xA	Fast CLK Bit Register	1XXXXXXXXb	Fast CLK bit	X	X	X	X	X	X	X

**Table 4. Writing and Reading Configuration Registers in Parallel Mode**

SPI_SEN	LD	WEN	REN	WCLK	RCLK	SPI_SCLK	Operation
1	0	0	1	↑ First rising edge because both LD and WEN are low	X	X	Parallel write to first register
1	0	0	1	↑ Second rising edge	X	X	Parallel write to second register
1	0	0	1	↑ Third rising edge	X	X	Parallel write to third register
1	0	0	1	↑ Fourth rising edge	X	X	Parallel write to fourth register
1	0	0	1	•	X	X	•
1	0	0	1	•	X	X	•
1	0	0	1	•	X	X	•
1	0	0	1	↑ Tenth rising edge	X	X	Parallel write to tenth register
1	0	0	1	↑ Eleventh rising edge	X	X	Parallel write to first register (roll back)
1	0	1	0	X	↑ First rising edge since both LD and REN are low	X	Parallel read from first register
1	0	1	0	X	↑ Second rising edge	X	Parallel read from second register
1	0	1	0	X	↑ Third rising edge	X	Parallel read from third register
1	0	1	0	X	↑ Fourth rising edge	X	Parallel read from fourth register
1	0	1	0	X	•	X	•
1	0	1	0	X	•	X	•
1	0	1	0	X	•	X	•
1	0	1	0	X	↑ Tenth rising edge	X	Parallel read from tenth register
1	0	1	0	X	↑ Eleventh rising edge	X	Parallel read from first register (roll back)
1	X	1	1	X	X	X	No operation
X	1	0	X	↑ Rising edge	X	X	Write to FIFO memory
X	1	X	0	X	↑ Rising edge	X	Read from FIFO memory
0	0	X	1	X	X	X	Illegal operation

**Table 5. Writing into Configuration Registers in Serial Mode**

SPI_SEN	LD	WEN	REN	WCLK	RCLK	SCLK	Operation
0	1	X	X	X	X	↑ Rising edge	Each rising of the SCLK clocks in one bit from the SI (Serial In). Any of the 10 registers can be addressed and written to, following the SPI protocol.
X	1	0	X	↑ Rising edge	X	X	Parallel write to FIFO memory.
X	1	X	0	X	↑ Rising edge	X	Parallel read from FIFO memory.
1	0	1	1	X	X	X	This corresponds to parallel mode (refer to <a href="#">Table 4 on page 11</a> ).

**Figure 2. Serial WRITE to Configuration Register**

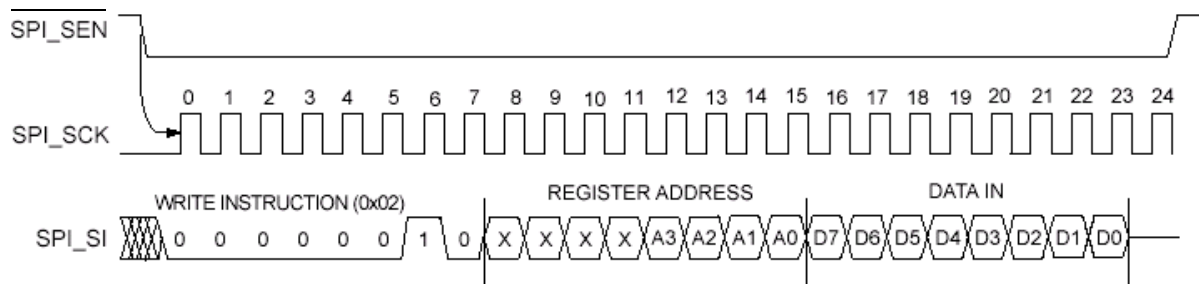

### Width Expansion Configuration

The width of CYFX072V can be expanded to provide word widths greater than 36 bits. During width expansion mode, all control line inputs are common and all flags are available. Empty (Full) flags are created by ANDing the Empty (Full) flags of every FIFO; the PAE and PAF flags can be detected from any one device. This technique avoids reading data from or writing data to the FIFO that is “staggered” by one clock cycle due to the variations in skew between RCLK and WCLK. Figure 3 demonstrates an example of 72 bit-word width by using two 36-bit word CYFX072Vs.

**Figure 3. Using Two CYFX072V for Width Expansion**

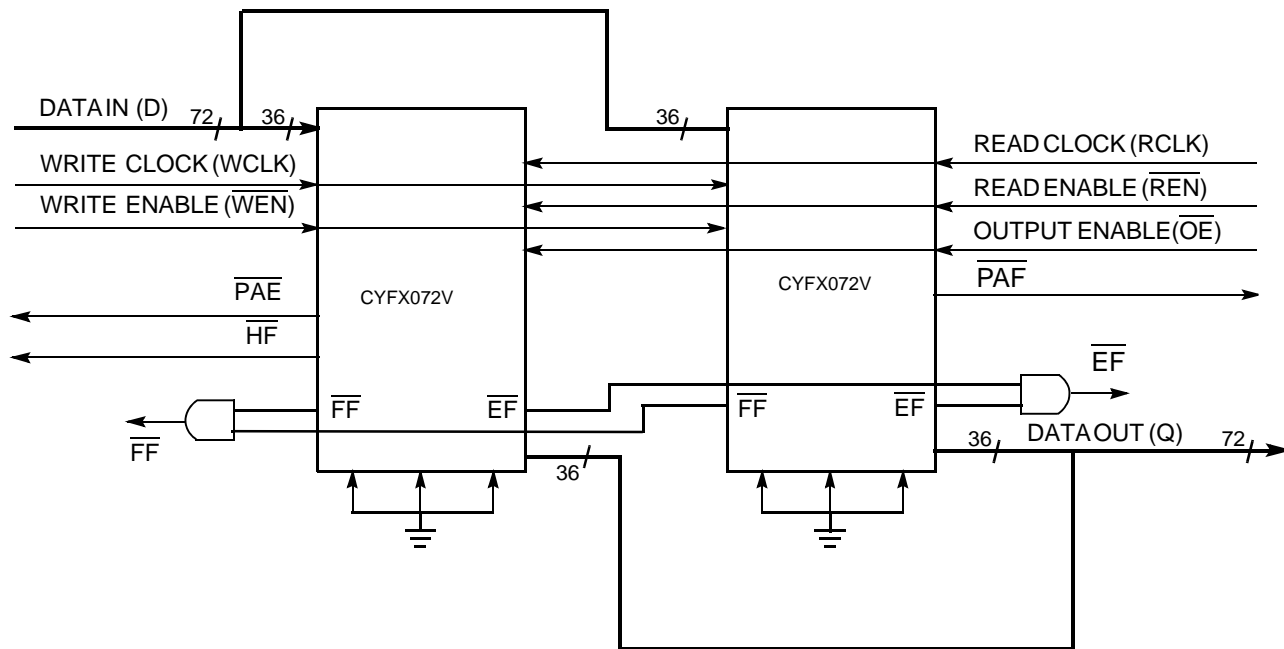

### Power Up

The device becomes functional after  $V_{CC1}$ ,  $V_{CC2}$ ,  $V_{CCIO}$ , and  $V_{REF}$  attain minimum stable voltage required as given in [Recommended DC Operating Conditions on page 15](#). The device can be accessed  $t_{PU}$  time after these supplies attain the minimum required level (see [Switching Characteristics on page 18](#)). There is no specific power sequencing required for the device.

### Read/Write Clock Requirements

The read and write clocks must satisfy the following requirements:

- Both read (RCLK) and write (WCLK) clocks should be free-running.
- The clock frequency for both clocks should be between the minimum and maximum range given in [Electrical Characteristics on page 15](#).
- The WCLK to RCLK ratio should be in the range of 0.5 to 2.

For proper FIFO operation, the device must determine which of the input clocks – RCLK or WCLK – is faster. This is evaluated using counters after the MRS cycle. The device uses two 9-bit counters (one running on RCLK and other on WCLK), which count 256 cycles of read and write clocks after MRS. The clock of the counter which reaches its terminal count first is used as master clock inside the FIFO.

When there is change in the relative frequency of RCLK and WCLK during normal operation of FIFO, user can specify it by using “Fast CLK bit” in the configuration register (0xA).

“1” - indicates  $f_{req}(WCLK) > f_{req}(RCLK)$

“0” - indicates  $f_{req}(WCLK) < f_{req}(RCLK)$

The result of counter evaluated frequency is available in this register bit. User can override the counter evaluated frequency for faster clock by changing this bit.

Whenever there is a change in this bit value, user must wait  $t_{PLL}$  time before issuing the next read or write to FIFO.

## JTAG Operation

CYFX072V has two devices connected internally in a JTAG chain as shown in Figure 4

**Figure 4. Device Connection in a JTAG Chain**

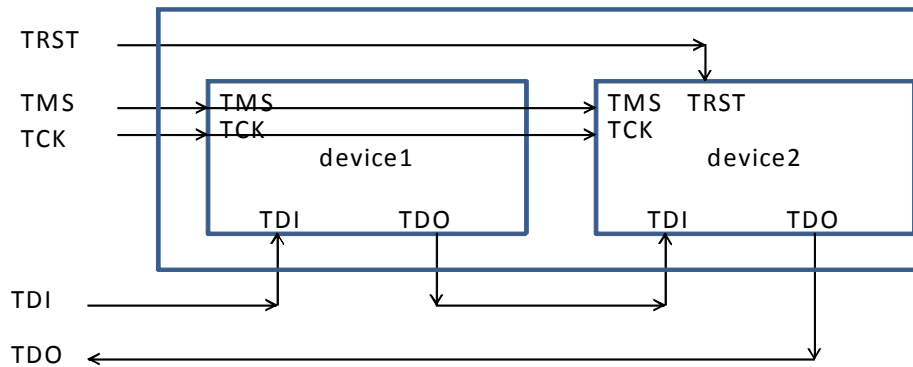

Table 6 shows the IR register length and device ID

**Table 6. JTAG IDCODES**

	IR Register Length	Device ID (HEX)	Bypass Register Length
Device-1	3	"Ignore"	1
Device-2	8	1E3261CF	1

**Table 7. JTAG Instructions for Device-1**

Device-1	Opcode (Binary)
BYPASS	111

**Table 8. JTAG Instructions for Device-2**

Device-2	Opcode (HEX)
EXTEST	00
HIGHZ	07
SAMPLE/PRELOAD	01
BYPASS	FF
IDCODE	0F

## Maximum Ratings

Exceeding maximum ratings may shorten the useful life of the device. These user guidelines are not tested.

Storage temperature (without bias) ..... -65 °C to +150 °C  
 Ambient temperature with power applied ..... -55 °C to +125 °C  
 Core supply voltage 1 ( $V_{CC1}$ ) to ground potential ..... -0.3 V to 2.5 V  
 Core supply voltage 2 ( $V_{CC2}$ ) to ground potential ..... -0.3 V to 1.65 V  
 Latch up current ..... >100 mA  
 I/O port supply voltage ( $V_{CCIO}$ ) ..... -0.3 V to 3.7 V

Voltage applied to I/O pins ..... -0.3 V to 3.75 V  
 Output current into outputs (LOW) ..... 24 mA  
 Static discharge voltage (per MIL-STD-883, Method 3015) ..... > 2001 V

## Operating Range

Range	Ambient Temperature
Industrial	-40 °C to +85 °C

## Recommended DC Operating Conditions

Parameter <sup>[5]</sup>	Description	Min	Typ	Max	Unit	
$V_{CC1}$	Core supply voltage 1	1.70	1.80	1.90	V	
$V_{CC2}$	Core supply voltage 2	1.425	1.5	1.575	V	
$V_{REF}$	Reference voltage (irrespective of I/O standard used)	0.7	0.75	0.8	V	
$V_{CCIO}$	I/O supply voltage, read and write banks.	LVC MOS33	3.00	3.30	3.60	V
		LVC MOS18	1.70	1.8	1.90	V

## Electrical Characteristics

Parameter	Description	Conditions	Min	Typ	Max	Unit
$I_{CC}$	Active current	$V_{CC1} = V_{CC1MAX}$	-	-	300	mA
		$V_{CC2} = V_{CC2MAX}$ (All I/O switching, 133 MHz)	-	-	600	mA
		$V_{CCIO} = V_{CCIO MAX}$ (All outputs disabled)	-	-	100	mA
$I_I$	Input pin leakage current	$V_{IN} = V_{CCIO max}$ to 0 V	-15	-	15	μA
$I_{OZ}$	I/O pin leakage current	$V_O = V_{CCIO max}$ to 0 V	-15	-	15	μA
$C_P$	Capacitance for TMS and TCK	-	-	-	16	pF
$C_{PIO}$	Capacitance for all other pins except TMS and TCK	-	-	-	8	pF

### Note

5. Device operation guaranteed for a supply rate > 1 V / μs.



## I/O Characteristics

(Over the operating range)

I/O standard	Nominal I/O supply voltage	Input Voltage (V)		Output voltage (V)		Output Current (mA)	
		V <sub>IL</sub> (max)	V <sub>IH</sub> (min)	V <sub>OL</sub> (max)	V <sub>OH</sub> (min)	I <sub>OL</sub> (max)	I <sub>OH</sub> (max)
LVC MOS33	3.3 V	0.80	2.20	0.45	2.40	24	24
LVC MOS18	1.8 V	30% V <sub>CCIO</sub>	65% V <sub>CCIO</sub>	0.45	V <sub>CCIO</sub> - 0.45	16	16

## Latency Table

Latency Parameter	Number of cycles	Detail
L <sub>FF_ASSERT</sub>	Max = 4	Last data write to FF going low.
L <sub>EF_ASSERT</sub>	0	Last data read to EF going low.
L <sub>PRS_TO_ACTIVE</sub>	32 <sup>[6]</sup>	PRS deassert to normal operation.
L <sub>MAILBOX</sub>	2	Latency from write port to read port when MB = 1 (wrt WCLK).
L <sub>REN_TO_DATA</sub>	4	Latency when REN is asserted low to first data output from FIFO.
L <sub>REN_TO_CONFIG</sub>	4	Latency when REN is asserted along with LD to first data read from configuration registers.
L <sub>WEN_TO_PAE_HI</sub>	5 <sup>[6]</sup>	Write to PAE going high.
L <sub>WEN_TO_PAF_LO</sub>	5 <sup>[6]</sup>	Write to PAF going low.
L <sub>REN_TO_PAE_LO</sub>	7 <sup>[6]</sup>	Read to PAE going low.
L <sub>REN_TO_PAF_HI</sub>	7 <sup>[6]</sup>	Read to PAF going high.
L <sub>FF_DEASSERT</sub>	8 <sup>[6]</sup>	Read to FF going high.
L <sub>RT_TO_REN</sub>	17	First RCLK posedge after RT goes low to initiation of reads by pulling REN low. Flags update within this period after initiation of a retransmit operation.
L <sub>RT_TO_DATA</sub>	Max = 21 <sup>[6]</sup>	First RCLK posedge after RT goes LOW to valid data on Q[35:0].
L <sub>IN</sub>	Max = 26 <sup>[6]</sup>	Initial latency for data read after FIFO goes empty during simultaneous read/write.
L <sub>EF_DEASSERT</sub>	Max = 24 <sup>[6]</sup>	Write to EF going high.
L <sub>FF_RELEASE</sub> <sup>[7]</sup>	Max = 6	EF going low to FF deassert during retransmit reads.

### Note

6. These latency values are valid for a clock ratio of 1.

7. **Errata:** Refer to [Errata](#) on page 31 for details on flag operation and full boundary freezing during Mark and Retransmit operation.

Figure 5. AC Test Load Conditions

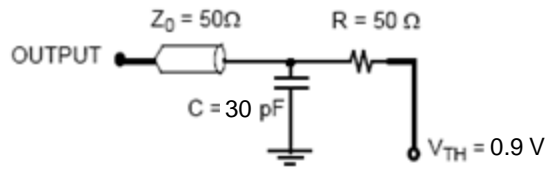

(a)  $V_{CCIO} = 1.8\text{ Volt}$

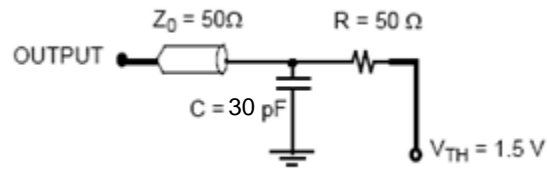

(b)  $V_{CCIO} = 3.3\text{ Volt}$

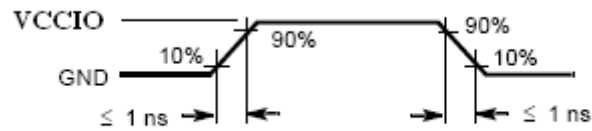

(c) All Input Pulses

## Switching Characteristics

Parameter	Description	-133		Unit	
		Min	Max		
t <sub>PU</sub>	Power-up time after all supplies reach minimum value	–	2	ms	
t <sub>S</sub>	Clock cycle frequency	3.3 V LVCMOS	24	133	MHz
t <sub>S</sub>	Clock cycle frequency	1.8 V LVCMOS	24	133	MHz
t <sub>A</sub>	Data access time	–	10	ns	
t <sub>CLK</sub>	Clock cycle time	7.5	41.67	ns	
t <sub>CLKH</sub>	Clock high time	3.375	–	ns	
t <sub>CLKL</sub>	Clock low time	3.375	–	ns	
t <sub>DS</sub>	Data setup time	3	–	ns	
t <sub>DH</sub>	Data hold time	3	–	ns	
t <sub>ENS</sub>	Enable setup time	3	–	ns	
t <sub>ENH</sub>	Enable hold time	3	–	ns	
t <sub>ENS_SI</sub>	Setup time for SPI_SI and $\overline{\text{SPI\_SEN}}$ pins	5	–	ns	
t <sub>ENH_SI</sub>	Hold time for SPI_SI and $\overline{\text{SPI\_SEN}}$ pins	5	–	ns	
t <sub>RATE_SPI</sub>	Frequency of SCLK	–	25	MHz	
t <sub>RS</sub>	Reset pulse width	100	–	ns	
t <sub>PZS</sub>	Port size select to $\overline{\text{MRS}}$ setup time	25	–	ns	
t <sub>PZH</sub>	$\overline{\text{MRS}}$ to port size select hold time	25	–	ns	
t <sub>RSF</sub>	Reset to flag output time	–	50	ns	
t <sub>PRT</sub>	Retransmit pulse width	5	–	RCLK cycles	
t <sub>OLZ</sub>	Output enable to output in Low Z	4	15	ns	
t <sub>OE</sub>	Output enable to output valid	–	15	ns	
t <sub>OHZ</sub>	Output enable to output in High Z	–	15	ns	
t <sub>WFF</sub>	Write clock to $\overline{\text{FF}}$	–	8.5	ns	
t <sub>REF</sub>	Read clock to $\overline{\text{EF}}$	–	8.5	ns	
t <sub>PAF</sub>	Clock to $\overline{\text{PAF}}$ flag	–	17	ns	
t <sub>PAE</sub>	Clock to $\overline{\text{PAE}}$ flag	–	17	ns	
t <sub>HF</sub>	Clock to $\overline{\text{HF}}$ flag	–	17	ns	
t <sub>PLL</sub>	Time required to synchronize PLL	–	1024	cycles	
t <sub>RATE_JTAG</sub>	JTAG TCK cycle time	100	–	ns	
t <sub>S_JTAG</sub>	Setup time for JTAG TMS,TDI	8	–	ns	
t <sub>H_JTAG</sub>	Hold time for JTAG TMS,TDI	8	–	ns	
t <sub>CO_JTAG</sub>	JTAG TCK low to TDO valid	–	20	ns	

## Switching Waveforms

Figure 6. Write Cycle Timing

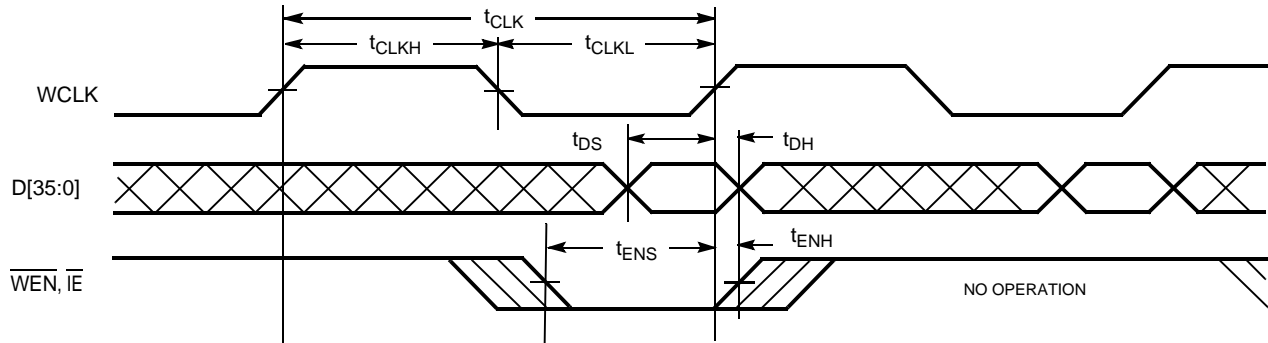
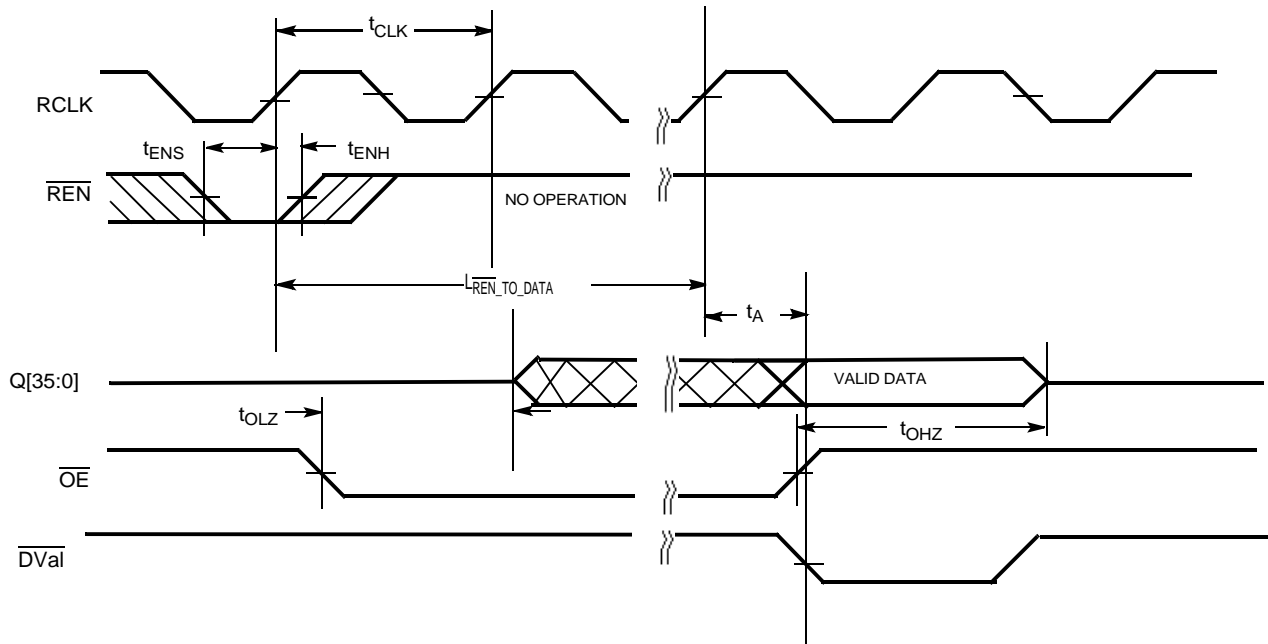

Figure 7. Read Cycle Timing



Switching Waveforms (continued)

Figure 8. Reset Timing

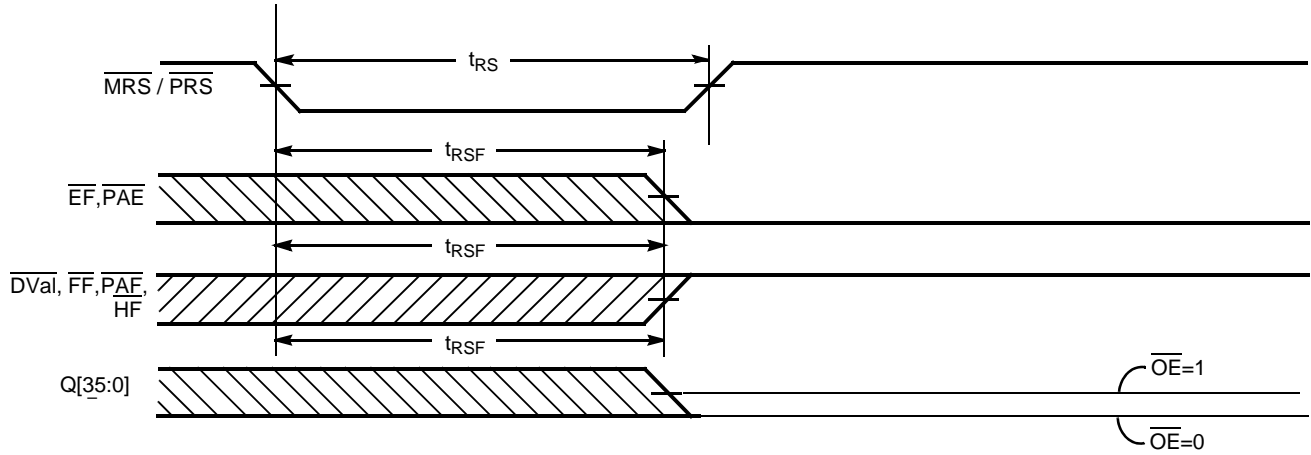
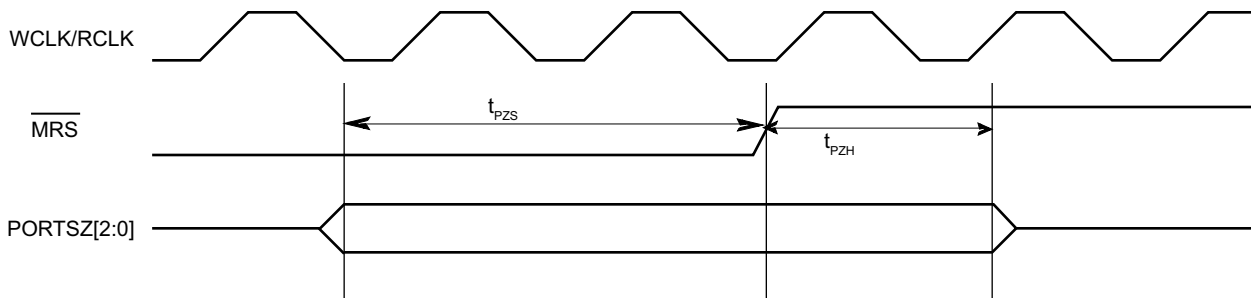

Figure 9.  $\overline{\text{MRS}}$  to PORTSZ[2:0]



Switching Waveforms (continued)

Figure 10. Empty Flag Timing

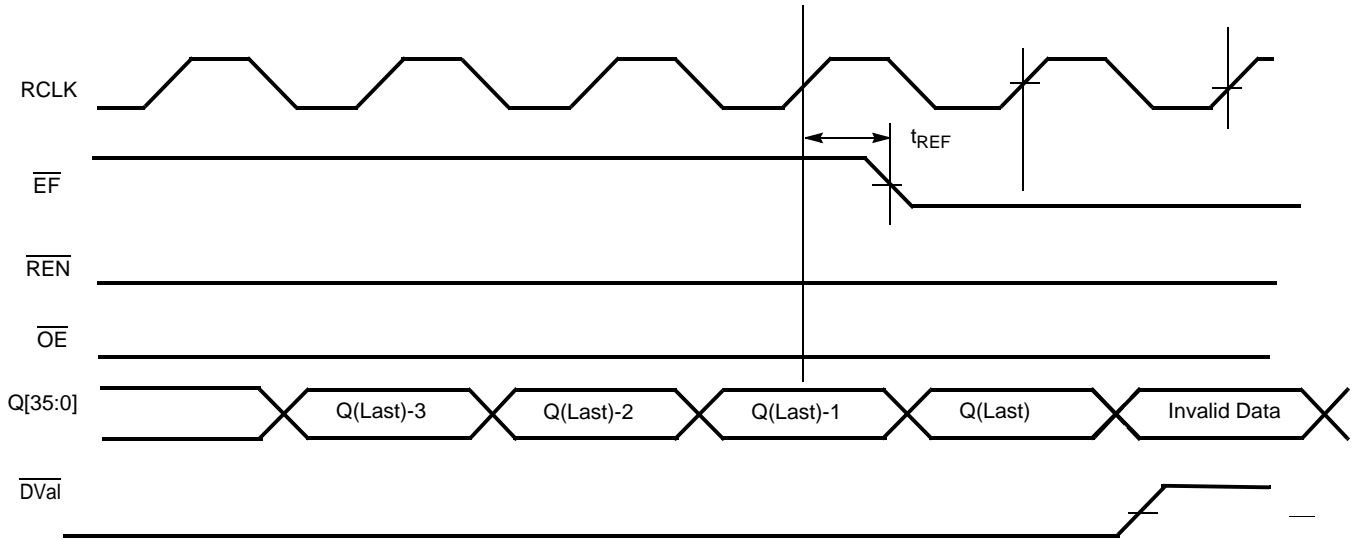
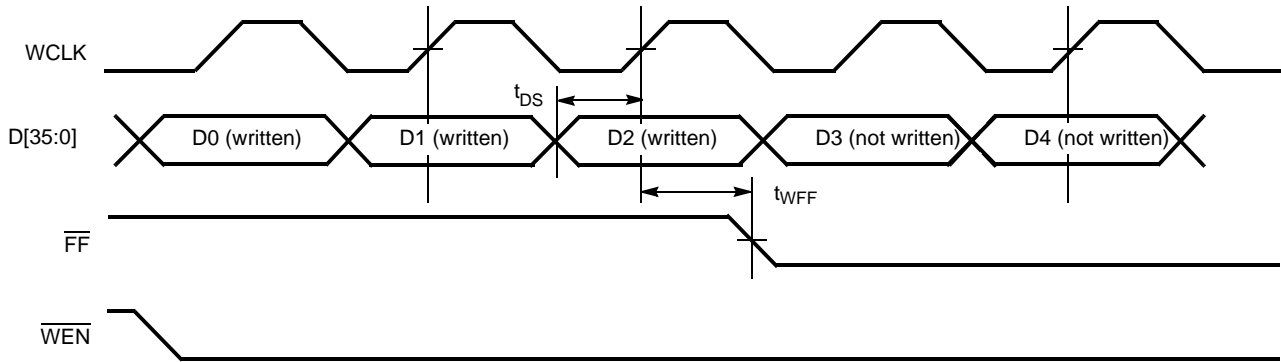

Figure 11. Full Flag Timing



Switching Waveforms (continued)

Figure 12. Initial Data Latency

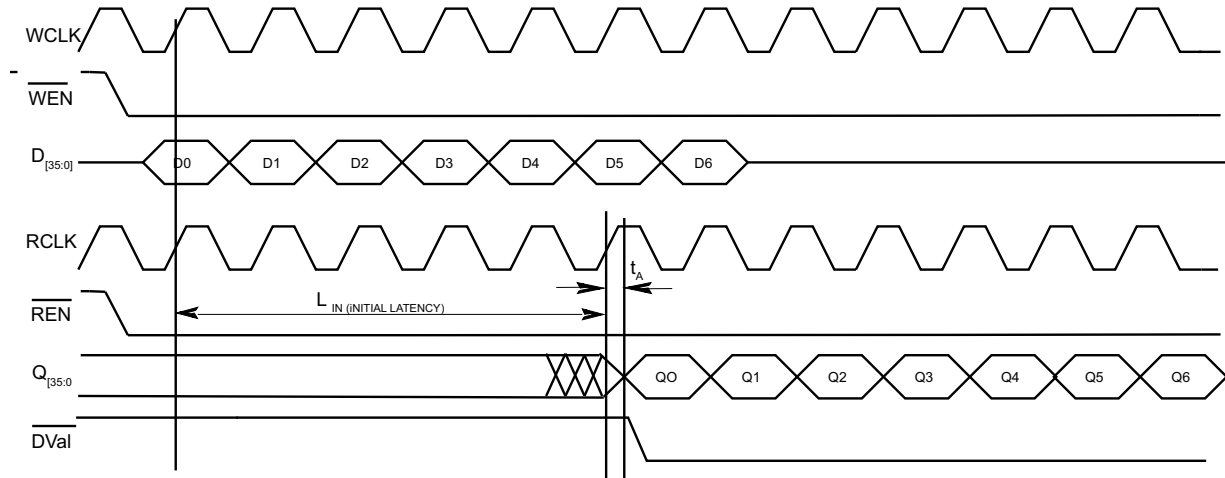
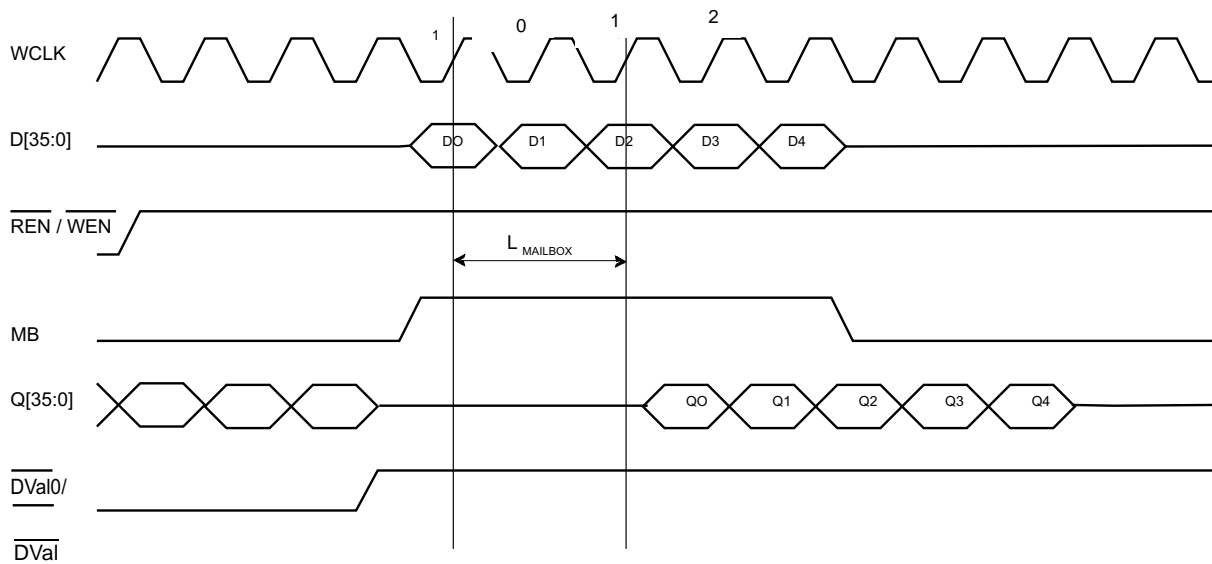

Figure 13. Flow-through Mailbox Operation





Switching Waveforms (continued)

Figure 14. Configuration Register Write

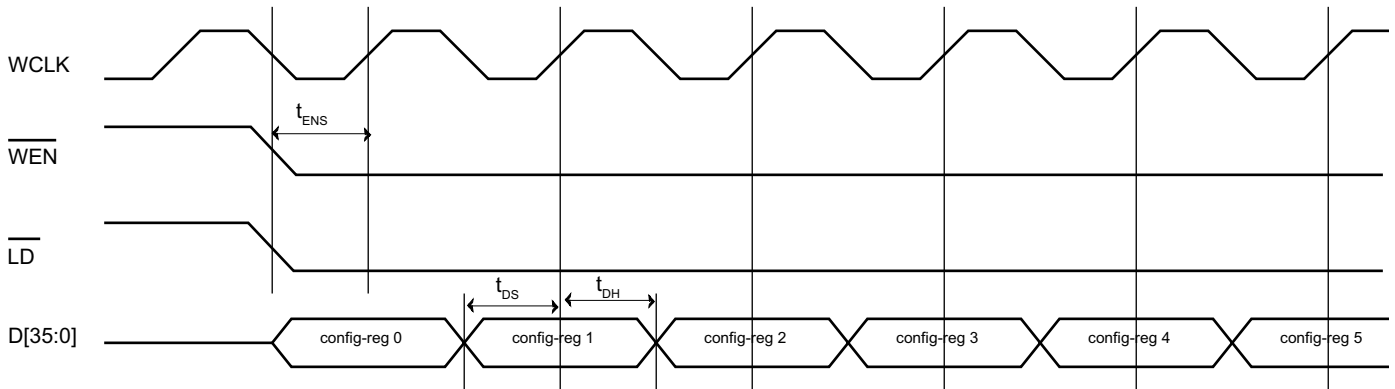

Figure 15. Configuration Register Read

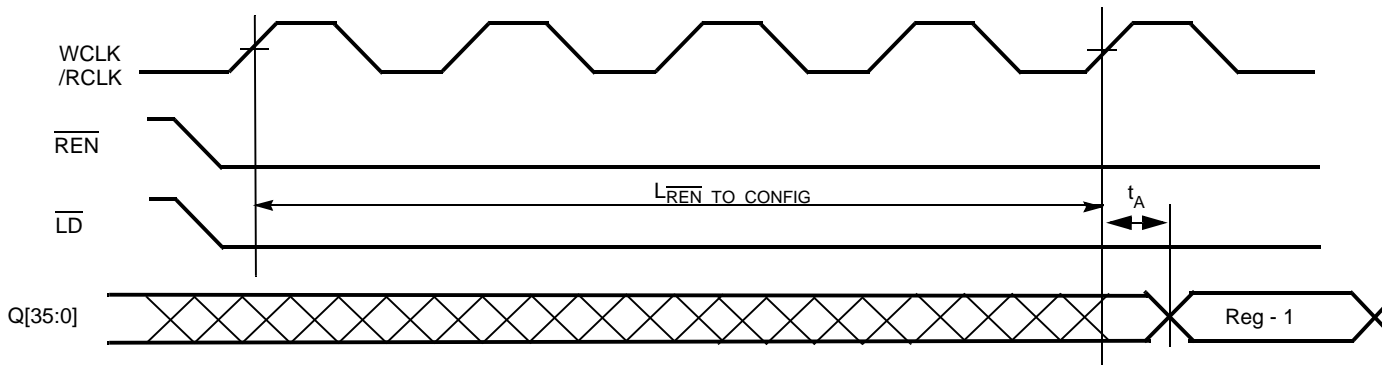
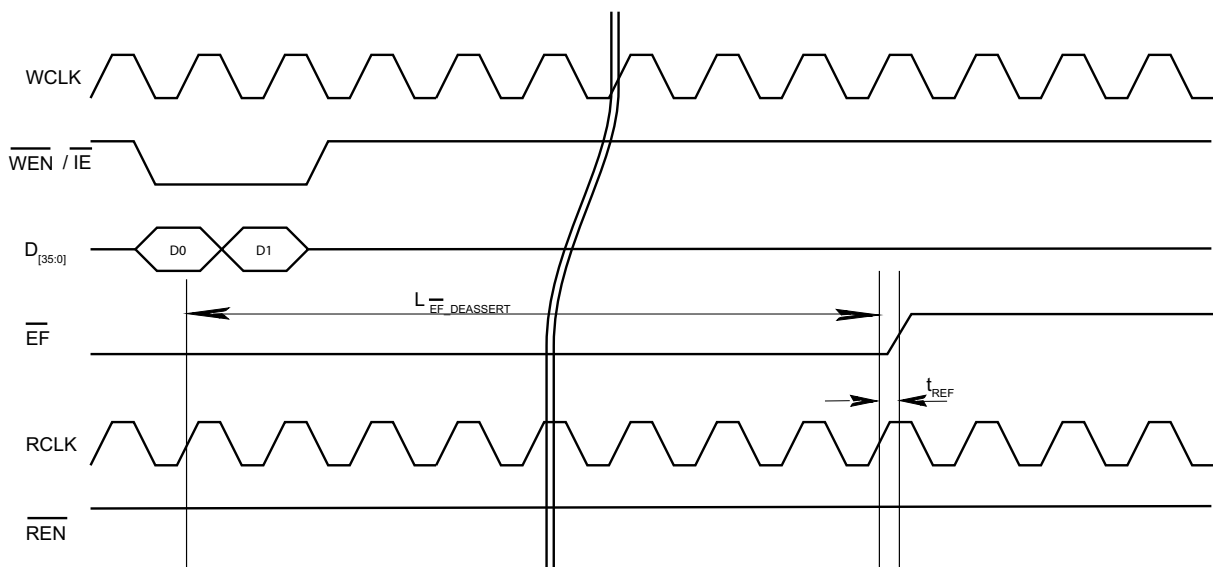

Figure 16. Empty Flag Deassertion



Switching Waveforms (continued)

Figure 17. Empty Flag Assertion

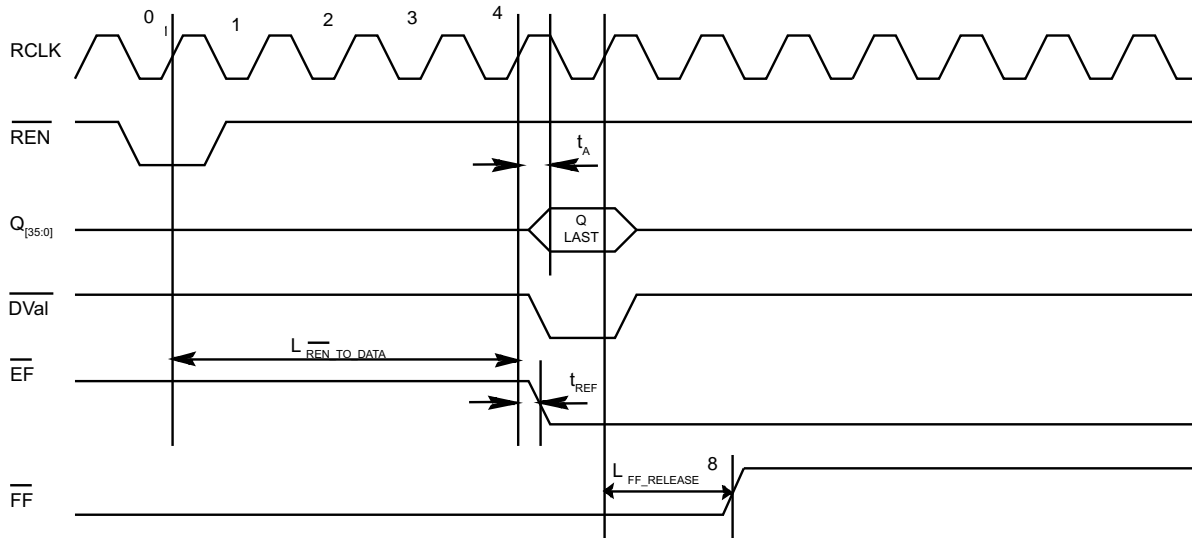
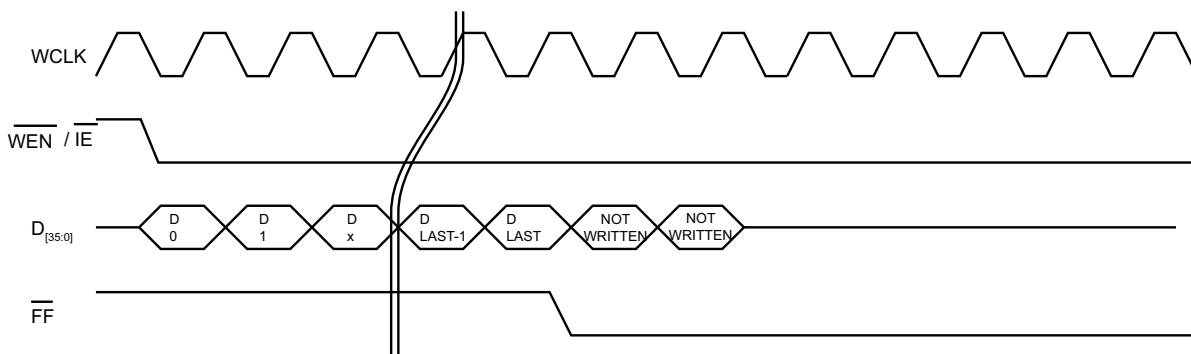

Figure 18. Full Flag Assertion



Note

8. Errata: Refer to Errata on page 31 for details on flag operation and full boundary freezing during Mark and Retransmit operation.

Switching Waveforms (continued)

Figure 19. Full Flag Deassertion

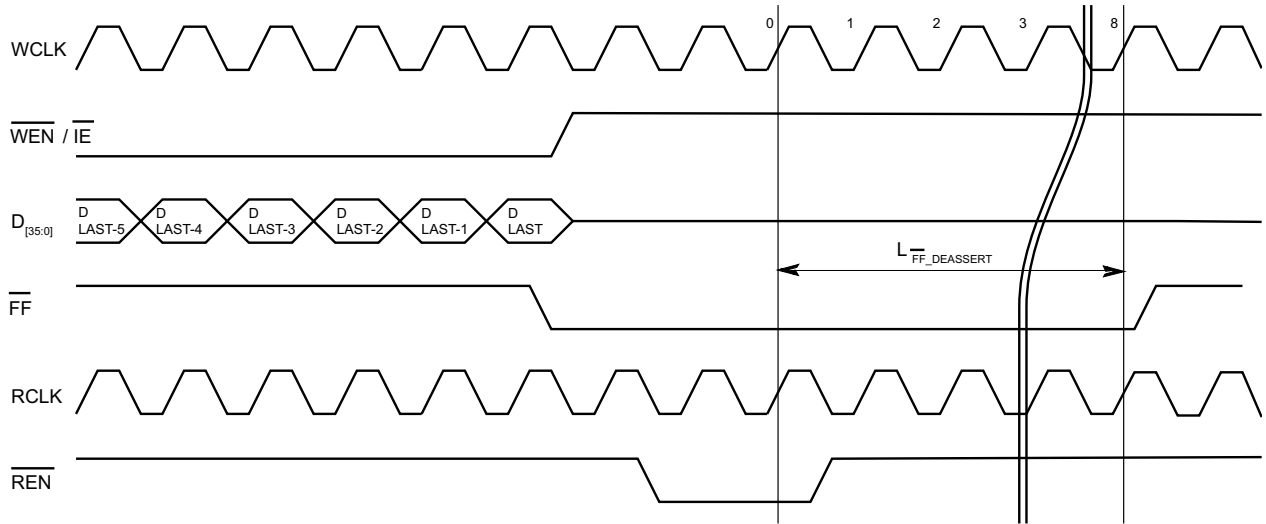
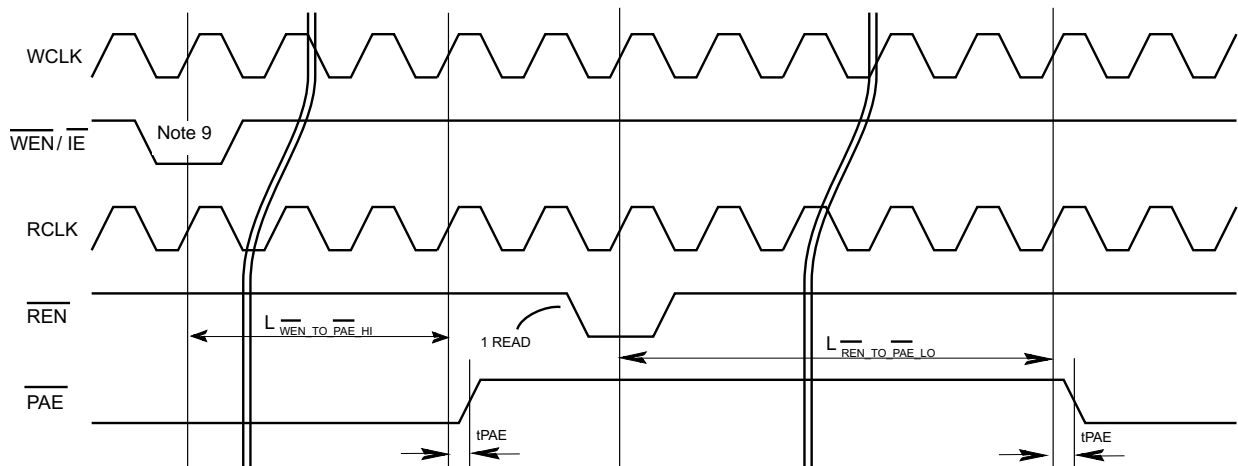

Figure 20. PAE Assertion and Deassertion



Note

9. Refer to Table 2 on page 8 and Latency Table on page 16 for the Programmable Flag boundaries.

Switching Waveforms (continued)

Figure 21.  $\overline{\text{PAF}}$  Assertion and Deassertion

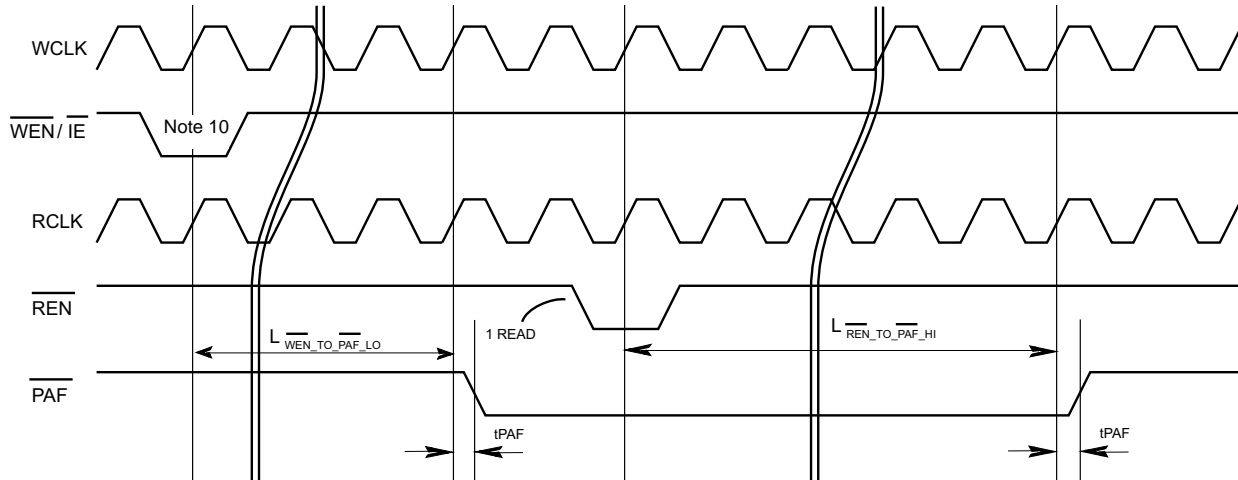
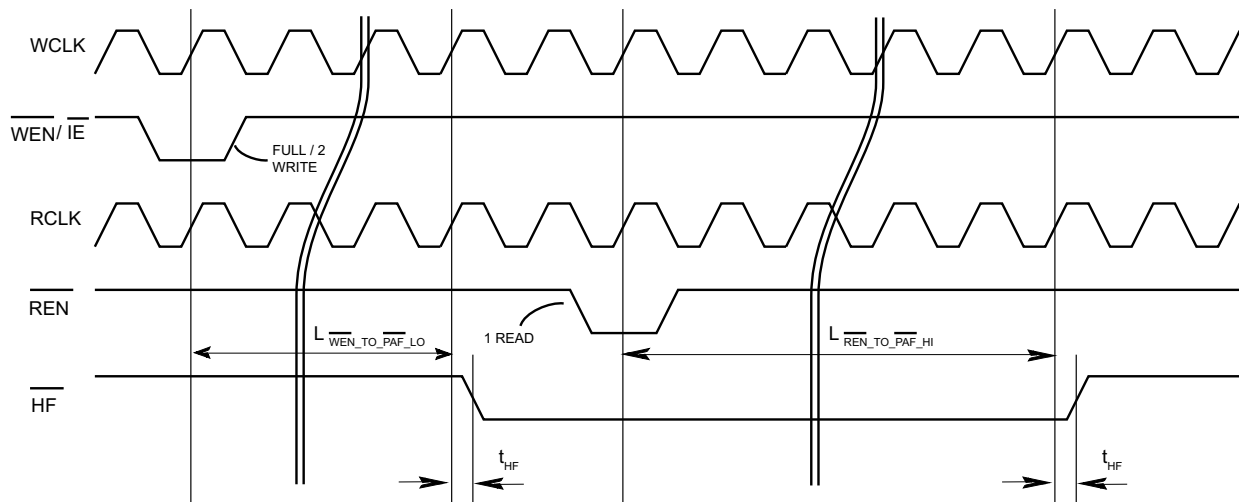

Figure 22.  $\overline{\text{HF}}$  Assertion and Deassertion



Note

10. Refer to Table 2 on page 8 and Latency Table on page 16 for the Programmable Flag boundaries.

Switching Waveforms (continued)

Figure 23. Mark

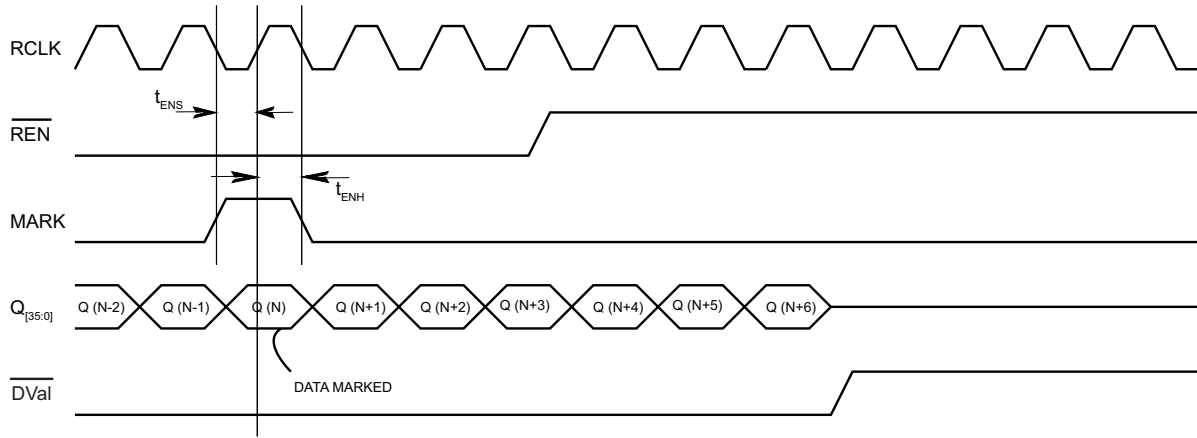
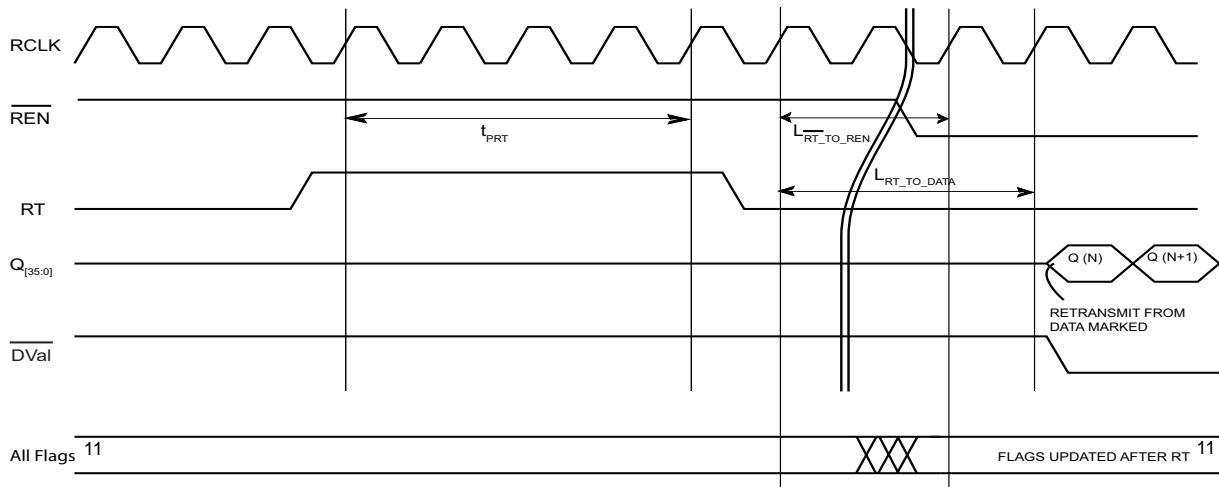

Figure 24. Retransmit



Note

11. Errata: Refer to Errata on page 31 for details on flag operation and full boundary freezing during Mark and Retransmit operation.

### Ordering Information

Speed (MHz)	Ordering Code	Package Diagram	Package Type	Operating Range
133	CYF0018V33L-133BGXI	51-85167	209-ball FBGA (14 x 22 x 1.76 mm)	Industrial
	CYF0036V33L-133BGXI			
	CYF0072V33L-133BGXI			
	CYF0018V18L-133BGXI			
	CYF0072V18L-133BGXI			

### Ordering Code Definitions

**CY F X XXX VXX X - XXX BGXI**

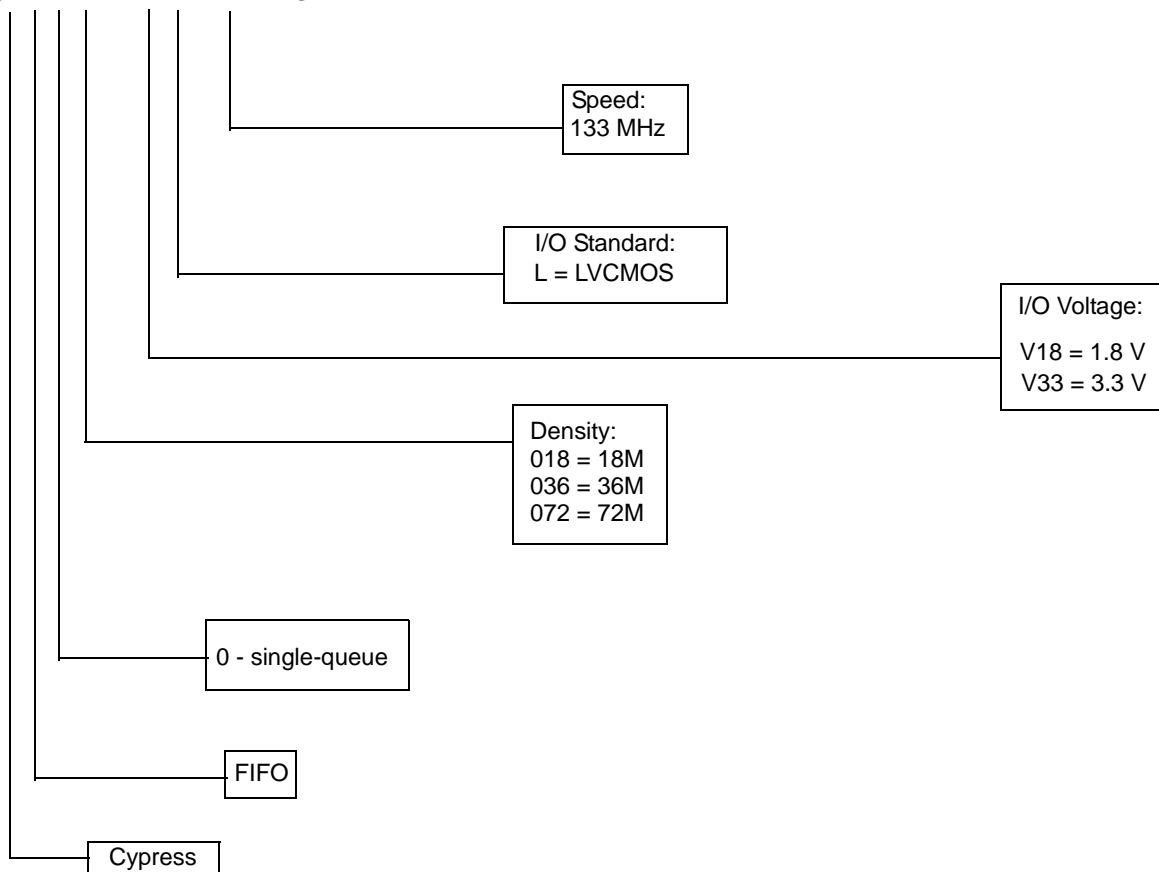

### Package Diagram

Figure 25. 209-ball FBGA (14 × 22 × 1.76 mm) BB209A Package Outline, 51-85167

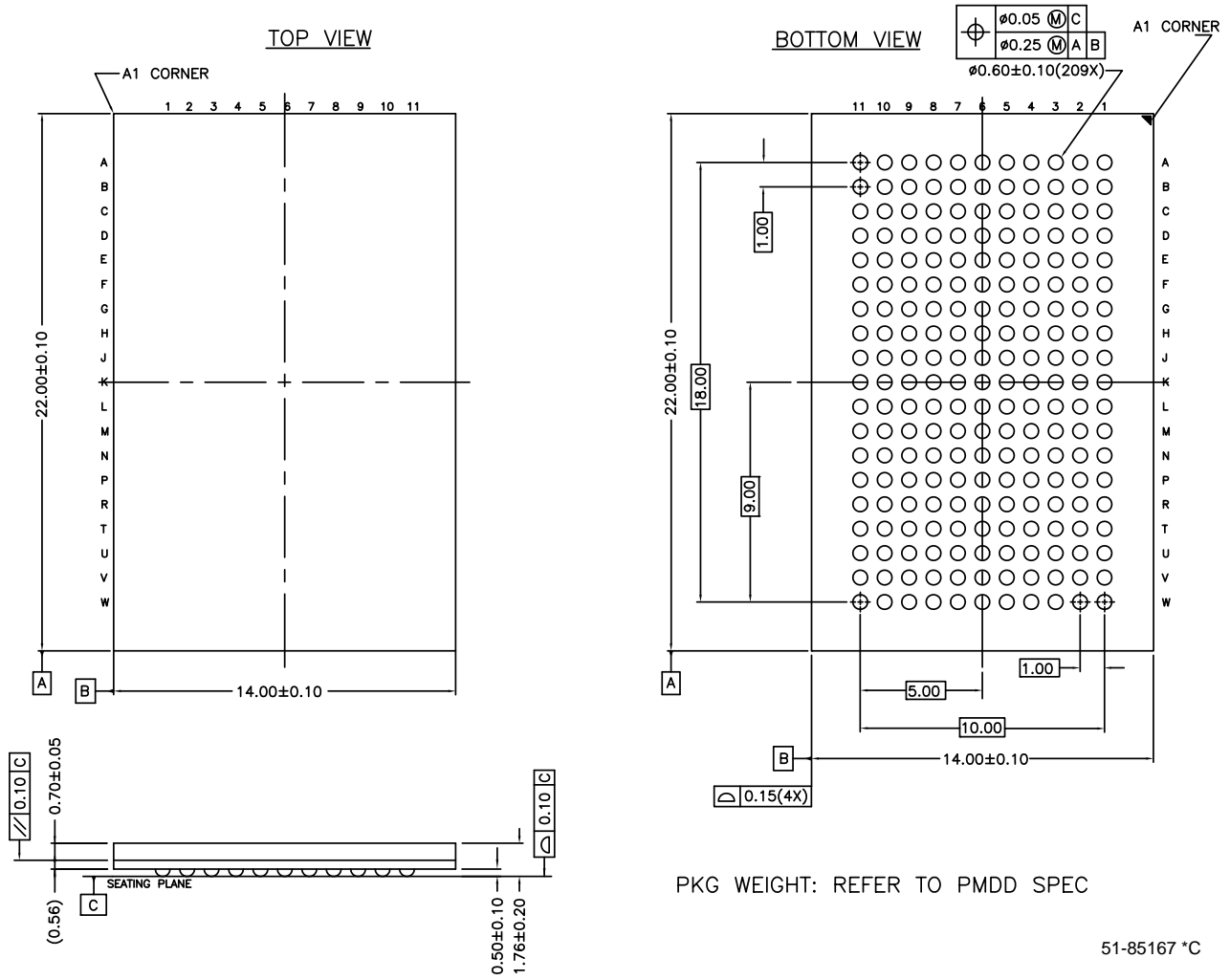



## Acronyms

Acronym	Description
FF	Full Flag
FIFO	First In First Out
HF	Half Full
$\overline{IE}$	Input Enable
I/O	Input/Output
FBGA	Fine-Pitch Ball Grid Array
JTAG	Joint Test Action Group
LSB	Least Significant Bit
LVC MOS	Low Voltage Complementary Metal Oxide Semiconductor
MB	Mailbox
$\overline{MRS}$	Master Reset
MSB	Most Significant Bit
$\overline{OE}$	Output Enable
PAF	Programmable Almost-Full
$\overline{PAE}$	Programmable Almost-Empty
PRS	Partial Reset
RCLK	Read Clock
REN	Read Enable
RCLK	Read Clock
SCLK	Serial Clock
TCK	Test Clock
TDI	Test Data In
TDO	Test Data Out
TMS	Test Mode Select
WCLK	Write Clock
$\overline{WEN}$	Write Enable

## Document Conventions

### Units of Measure

Symbol	Unit of Measure
°C	degree Celsius
MHz	megahertz
μA	microampere
mA	milliampere
mm	millimeter
ms	millisecond
ns	nanosecond
Ω	ohm
pF	picofarad
V	volt
W	watt

## Errata

This section describes the errata for the 18-Mbit, 36-Mbit, and 72-Mbit programmable FIFOs. Details include errata trigger conditions, scope of impact, available workaround, and silicon revision applicability. Contact your local Cypress Sales Representative or raise a technical support case at [www.cypress.com/support](http://www.cypress.com/support) if you have questions.

### Part Numbers Affected

Part Number	Device Characteristics
CYF0018V33L-133BGXI	18-Mbit Programmable Single-Queue FIFOs (3.3-V LVCMOS)
CYF0018V18L-133BGXI	18-Mbit Programmable Single-Queue FIFO (1.8-V LVCMOS)
CYF0036V33L-133BGXI	36-Mbit Programmable Single-Queue FIFO (3.3-V LVCMOS)
CYF0072V33L-133BGXI	72-Mbit Programmable Single-Queue FIFO (3.3-V LVCMOS)
CYF0072V18L-133BGXI	72-Mbit Programmable Single-Queue FIFO (1.8-V LVCMOS)
CYF2072V33L-100BGXI	72-Mbit Programmable Eight-Queue FIFO (3.3-V LVCMOS)

### 18-Mbit, 36-Mbit, and 72-Mbit Programmable FIFO Qualification Status

Product Status: In Production

### 18-Mbit, 36-Mbit, and 72-Mbit Programmable FIFO Errata Summary

This table defines the errata applicability to available 18-Mbit, 36-Mbit, and 72-Mbit Programmable FIFO family devices. An “X” indicates that the erratum pertains to the selected device.

Items	Part Numbers	Silicon Revision	Fix Status
1. Retransmit Issue	CYF0018V CYF0036V	X	Fix in progress.
	CYF0072V CYF2072V	X	Fixed parts with date code on or after WW1331.
2. Full Boundary Freezing	CYF0018V CYF0036V	X	Fix in progress.
	CYF0072V CYF2072V	X	Fixed parts with date code on or after WW1331.

## 1. Retransmit Issue

### ■ Problem Definition

Flag Failure during Retransmit cycles: Flags ( $\overline{\text{PAE}}$ ,  $\overline{\text{HF}}$ ,  $\overline{\text{PAF}}$ , and  $\overline{\text{FF}}$ ) are not updated during a retransmit cycle. These flags do not recover on completion of retransmit cycles. The functionality of Empty Flag (EF) and Data Valid signal (DVal) remain intact throughout device operation.

### ■ Parameters Affected

Because flags ( $\overline{\text{PAE}}$ ,  $\overline{\text{HF}}$ ,  $\overline{\text{PAF}}$ , and  $\overline{\text{FF}}$ ) are not updated during a retransmit cycle, their associated latencies and timing parameters are not applicable.

### ■ Trigger Condition

Initiation of a retransmit cycle using RT signal.

### ■ Scope of Impact

On initiation of a retransmit cycle, flags ( $\overline{\text{PAE}}$ ,  $\overline{\text{HF}}$ ,  $\overline{\text{PAF}}$ , and  $\overline{\text{FF}}$ ) may not accurately reflect FIFO status. Customer applications relying on these flags to keep track of number of words in the FIFO during retransmit may observe errors because these flags are not updated. The failure mandates a reset cycle (Partial Reset for Single queue and Master Reset for Multi queue devices) to ensure flag recovery after a retransmit cycle, that is, to restore flag functionality and resume normal FIFO operations after completion of retransmit cycles.

### ■ Workaround

During retransmit cycles, there is no workaround to restore  $\overline{\text{PAE}}$ ,  $\overline{\text{HF}}$ ,  $\overline{\text{PAF}}$ , and  $\overline{\text{FF}}$  functionalities.

After completion of retransmit cycles, a reset cycle (Partial Reset for Single queue and Master Reset for Multi queue devices) can be performed to restore  $\overline{\text{PAE}}$ ,  $\overline{\text{HF}}$ ,  $\overline{\text{PAF}}$ , and  $\overline{\text{FF}}$  functionalities for normal FIFO operation.

### ■ Fix Status

The fix for the retransmit issue is in progress. In devices with the design fix, the intended flag functionality will be restored during retransmit cycles. Reset will not be mandatory after a retransmit cycle to resume normal FIFO operation. Fixed devices will be available from February 04, 2013.

## 2. Full Boundary Freezing

### ■ Problem Definition

Full Boundary Freezing: On initiation of RT, the marked location (marked using the MARK pin) does not become the new Full Flag boundary.

### ■ Parameters Affected

$L_{\text{FF\_RELEASE}}$ : For CYF0018V & CYF0036V, marked location does not become the new Full boundary on initiation of a retransmit operation. Hence, this parameter is affected.

### ■ Trigger Condition

Not Applicable.

### ■ Scope of Impact

On initiation of RT, data written into the FIFO memory beyond the marked location will be considered as FIFO overflow. This causes data loss.

### ■ Workaround

There is no workaround to avoid overflow in devices without the design fix.

### ■ Fix Status

In devices with the design fix, the marked location becomes a new Full Boundary. Fixed devices with marked location as new Full Boundary is available for 72M devices (CYF0072V & CYF2072V) with the date code on or after WW1331 (August 2013). For CYF0018V & CYF0036V, fix on Full boundary freezing issue is in progress.

## Document History Page

Document Title: CYF0018V/CYF0036V/CYF0072V, 18/36/72-Mbit Programmable FIFOs				
Document Number: 001-53687				
Revision	ECN	Orig. of Change	Submission Date	Description of Change
**	2711566	VKN / PYRS	05/27/09	New data sheet.
*A	2725088	NXR	06/26/2009	Included pinout, AC and DC specs, timing diagrams and package diagram
*B	2839536	NXR	01/28/2010	Changed Balls B5, D5, F6, K1, K2, K4, K8 and U2 from NC to DNU, Balls C5, C7, G6, H6, J6, L6, M6, N6, T5, T7 from NC to VCC1, Balls K9, K10, K11 from NC to VCCIOR, Ball W9 from NC to Vref in pin configuration table Swapped Voltage range of V <sub>SS1</sub> and V <sub>SS2</sub> Updated I <sub>CC</sub> spec Removed T <sub>SKEW</sub> parameter Added Ordering Information table Added Part Numbering Nomenclature. Changed title to CYF0018V/CYF0036V/CYF0072V/CYFX144VXXX, 18/36/72-Mbit Programmable FIFOs.
*C	2884377	HKV	02/25/2010	Post to external web.
*D	2963225	AJU / HPV	06/28/2010	Changed frequency of operation from 250 MHz to 150 MHz Removed Depth Expansion feature and changed associated pin functionality Removed Independent Port size selectability feature Added Data Valid (DVal) signal feature Updated Logic Block Diagram to reflect above changes. Pinout changes: Balls V5, V8, A7, B7, D7, and C6 renamed DNU Ball U1 changed from RXO to DVal Ball V2 changed from WXO/HF to HF Ball A5, A6, B6 changed from WPORTSZ to PORTSZ Ball A9 changed from RT/FL to RT Renamed pwr as POWER, gnd as GND Added <a href="#">Table 4</a> Table 6 – LD changed to ‘1’ for serial writes Updated <a href="#">Electrical Characteristics</a> and <a href="#">I/O Characteristics</a> Switching Characteristics Table: Renamed tPC as tPU Min frequency changed from 110MH to 24MHz Changed t <sub>CLKH</sub> and t <sub>CLKL</sub> to 3.15 ns Changed All setup and hold times to 3 ns Changed t <sub>RSF</sub> to 50 ns Removed t <sub>RSR</sub> Changed All clock-to-flag timing to min = 8 ns and max = 14 ns T <sub>PLL</sub> changed to 6 ms Changed all OE-related parameters to 15 ns Scaled I <sub>CC</sub> for reduced frequency Updated all waveforms Added the following table: “Word Size Selection”. Added the sections <a href="#">JTAG Operation</a> , and <a href="#">Latency Table</a> Added <a href="#">Acronyms</a> .
*E	2994379	AJU	07/26/2010	Updated <a href="#">Ordering Information</a>
*F	3101023	SIVS	12/03/2010	Added supply-wise current consumption data in <a href="#">Electrical Characteristics</a> . Changed initial latency L <sub>IN</sub> from 34 to 26 and added initial latency L <sub>IN</sub> for 110 MHz part in <a href="#">Latency Table</a> . Added 110 MHz part information in <a href="#">JTAG Operation</a> Added details for the 110 MHz part in <a href="#">Switching Characteristics</a> . Added details for the 110 MHz part in <a href="#">Ordering Information</a> .

Document History Page (continued)

Document Title: CYF0018V/CYF0036V/CYF0072V, 18/36/72-Mbit Programmable FIFOs				
Document Number: 001-53687				
Revision	ECN	Orig. of Change	Submission Date	Description of Change
*G	3129722	HKV	01/06/2011	Post to external web.
*H	3197271	SIVS	03/31/2011	Removed 144 Mbit parts from the data sheet Removed multi-queue information from data sheet Removed 2.5 V and 1.5 V options Removed HSTL I/II I/O standard Added clock ratio requirement between RCLK and WCLK Removed redundant Xs from part number to improve readability Removed tie to GND option on DNU pins in pin description Added information on Flag operations to add clarity Added explanation for flow-through mailbox operation Added details on active pins in various port sizes in Table 1. Added Configuration register write to normal operation latency details. Changed configuration register definitions and default values Changed number of unusable locations to four to eight Added JTAG related operation Added latch-up current parameter in maximum operating conditions. Removed 2.5 V and 1.5 V options from DC operating condition table 6. Removed 110 MHz part details and added Cpio parameter in table 7. Removed 2.5 V and 1.5 V options from Table 8. Added latency parameters in Table 9. changed V <sub>OL</sub> (max) value of LVCMOS33 in table11 Removed 110 MHz part detail from switching characteristics Added timing waveform to improve clarity. Modified ordering information and definition.
*I	3388143	AJU	09/29/2011	Updated <a href="#">Pin Diagram for CYF0XXXVXXL [1]</a> (Added Note 2 and referred the same note in DNU in ball U6). Updated <a href="#">Programming Flag Offsets and Configuration Registers</a> (Updated <a href="#">Table 4</a> (WCLK column in first row)). Updated <a href="#">Recommended DC Operating Conditions</a> (Added Note 5 and referred the same note in Parameter column). Updated <a href="#">Latency Table</a> (Changed Details for the parameters $L_{\overline{WEN\_TO\_PAE\_HI}}$ and $L_{\overline{REN\_TO\_PAE\_LO}}$ ). Updated <a href="#">Switching Waveforms</a> (Removed the clock cycle numbers in <a href="#">Figure 12</a> , <a href="#">Figure 13</a> , <a href="#">Figure 17</a> , and <a href="#">Figure 19</a> ). Updated <a href="#">Package Diagram</a> . Updated in new template.
*J	3652368	ADMU	08/16/2012	Updated <a href="#">Pin Diagram for CYF0XXXVXXL [1]</a> (Updated <a href="#">Figure 1 on page 4</a> (W9 ball marked as DNU)). Added <a href="#">Figure 5</a> (Test Load Conditions). Updated <a href="#">Switching Characteristics</a> (Changed minimum values of t <sub>S_JTAG</sub> , t <sub>H_JTAG</sub> parameters from 5 ns to 8 ns, changed maximum value of t <sub>CO_JTAG</sub> parameter from 10 ns to 20 ns).
*K	3735896	ADMU	09/07/2012	Updated package diagram 51-85167 to *C Updated "Output current into outputs (LOW)" parameter under Maximum Ratings section from 20 mA to 24 mA.

Document History Page (continued)

Document Title: CYF0018V/CYF0036V/CYF0072V, 18/36/72-Mbit Programmable FIFOs Document Number: 001-53687				
Revision	ECN	Orig. of Change	Submission Date	Description of Change
*L	3940217	ADMU	03/22/2013	Updated <a href="#">Features</a> . Updated <a href="#">Functional Description</a> . Updated <a href="#">Logic Block Diagram</a> . Updated <a href="#">Pin Diagram for CYF0XXXVXXL [1]</a> : Added Note 1 and referred the same note in <a href="#">Figure 1</a> . Updated <a href="#">Pin Definitions</a> . Updated <a href="#">Architecture</a> : Updated <a href="#">Reset Logic, Data Valid Signal (DVal), Flag Operation, Retransmit from Mark Operation, Programming Flag Offsets and Configuration Registers, Read/Write Clock Requirements</a> . Added <a href="#">Table 2</a> . Updated <a href="#">Latency Table</a> . Updated <a href="#">Switching Waveforms</a> : Updated <a href="#">Figure 12, Figure 13, Figure 17, Figure 19, Figure 20, Figure 21, Figure 22, Figure 24</a> . Added Note 9 and referred the same note in $\overline{WEN} / \overline{IE}$ in <a href="#">Figure 20</a> . Added Note 10 and referred the same note in $\overline{WEN} / \overline{IE}$ in <a href="#">Figure 21</a> . Updated <a href="#">Ordering Information</a> (Updated part numbers).
*M	3997615	ADMU	05/11/2013	Added <a href="#">Errata</a> .
*N	4078255	ADMU	07/26/2013	Added Errata footnotes (Note 4, 7, 8, 11). Updated <a href="#">Architecture</a> : Updated <a href="#">Retransmit from Mark Operation</a> : Added Note 4 and referred the same note in 2nd paragraph and last paragraph. Updated <a href="#">Latency Table</a> : Added Note 7 and referred the same note in "L <sub>FF</sub> _RELEASE" parameter. Updated <a href="#">Switching Waveforms</a> : Added Note 8 and referred the same note in "L <sub>FF</sub> _RELEASE" in <a href="#">Figure 17</a> . Added Note 11 and referred the same note in "All Flags" and "FLAGS UPDATED AFTER RT" in <a href="#">Figure 24</a> . Updated in new template.
*O	4202562	SMCH	11/27/2013	Updated <a href="#">Errata</a> .
*P	4580426	SMCH	11/25/2014	Added related documentation hyperlink in page 1.

## Sales, Solutions, and Legal Information

### Worldwide Sales and Design Support

Cypress maintains a worldwide network of offices, solution centers, manufacturer's representatives, and distributors. To find the office closest to you, visit us at [Cypress Locations](#).

#### Products

<a href="#">Automotive</a>	<a href="#">cypress.com/go/automotive</a>
<a href="#">Clocks &amp; Buffers</a>	<a href="#">cypress.com/go/clocks</a>
<a href="#">Interface</a>	<a href="#">cypress.com/go/interface</a>
<a href="#">Lighting &amp; Power Control</a>	<a href="#">cypress.com/go/powerpsoc</a> <a href="#">cypress.com/go/plc</a>
<a href="#">Memory</a>	<a href="#">cypress.com/go/memory</a>
<a href="#">PSoC</a>	<a href="#">cypress.com/go/psoc</a>
<a href="#">Touch Sensing</a>	<a href="#">cypress.com/go/touch</a>
<a href="#">USB Controllers</a>	<a href="#">cypress.com/go/USB</a>
<a href="#">Wireless/RF</a>	<a href="#">cypress.com/go/wireless</a>

#### PSoC<sup>®</sup> Solutions

[psoc.cypress.com/solutions](#)  
[PSoC 1](#) | [PSoC 3](#) | [PSoC 4](#) | [PSoC 5LP](#)

#### Cypress Developer Community

[Community](#) | [Forums](#) | [Blogs](#) | [Video](#) | [Training](#)

#### Technical Support

[cypress.com/go/support](#)

---

© Cypress Semiconductor Corporation, 2009-2014. The information contained herein is subject to change without notice. Cypress Semiconductor Corporation assumes no responsibility for the use of any circuitry other than circuitry embodied in a Cypress product. Nor does it convey or imply any license under patent or other rights. Cypress products are not warranted nor intended to be used for medical, life support, life saving, critical control or safety applications, unless pursuant to an express written agreement with Cypress. Furthermore, Cypress does not authorize its products for use as critical components in life-support systems where a malfunction or failure may reasonably be expected to result in significant injury to the user. The inclusion of Cypress products in life-support systems application implies that the manufacturer assumes all risk of such use and in doing so indemnifies Cypress against all charges.

Any Source Code (software and/or firmware) is owned by Cypress Semiconductor Corporation (Cypress) and is protected by and subject to worldwide patent protection (United States and foreign), United States copyright laws and international treaty provisions. Cypress hereby grants to licensee a personal, non-exclusive, non-transferable license to copy, use, modify, create derivative works of, and compile the Cypress Source Code and derivative works for the sole purpose of creating custom software and or firmware in support of licensee product to be used only in conjunction with a Cypress integrated circuit as specified in the applicable agreement. Any reproduction, modification, translation, compilation, or representation of this Source Code except as specified above is prohibited without the express written permission of Cypress.

Disclaimer: CYPRESS MAKES NO WARRANTY OF ANY KIND, EXPRESS OR IMPLIED, WITH REGARD TO THIS MATERIAL, INCLUDING, BUT NOT LIMITED TO, THE IMPLIED WARRANTIES OF MERCHANTABILITY AND FITNESS FOR A PARTICULAR PURPOSE. Cypress reserves the right to make changes without further notice to the materials described herein. Cypress does not assume any liability arising out of the application or use of any product or circuit described herein. Cypress does not authorize its products for use as critical components in life-support systems where a malfunction or failure may reasonably be expected to result in significant injury to the user. The inclusion of Cypress' product in a life-support systems application implies that the manufacturer assumes all risk of such use and in doing so indemnifies Cypress against all charges.

Use may be limited by and subject to the applicable Cypress software license agreement.

# Mouser Electronics

Authorized Distributor

Click to View Pricing, Inventory, Delivery & Lifecycle Information:

[Cypress Semiconductor:](#)

[CYF0072V33L-133BGXI](#)