

# Disc Type Capacitors with Lead

High Voltage Ceramic Capacitors  
Automotive Grade

Safety Standard Approved  
CS series

Issue date: March 2013

- All specifications are subject to change without notice.
  - Conformity to RoHS Directive: This means that, in conformity with EU Directive 2002/95/EC, lead, cadmium, mercury, hexavalent chromium, and specific bromine-based flame retardants, PBB and PBDE, have not been used, except for exempted applications.
-

# Disc Type Capacitors with Lead

Conformity to RoHS Directive

High Voltage Ceramic Capacitors  
Automotive Grade

Safety Standard Approved  
CS Series

## BASIC INSULATION TYPE CLASS 2 HIGH DIELECTRIC

### FEATURES

- AEC-Q200 compliant.
- 1,000 cycles guaranteed under heat shock testing at  $-55^{\circ}\text{C}$  to  $+125^{\circ}\text{C}$ .
- It can be used as a Y capacitor for battery chargers used in automobiles (EV, PHEV).
- Compliant with IEC and the safety standards of various countries.
- Rated at a withstand voltage of AC.2600V.
- Compatible with halogen-free external resin coating.

**OPERATING TEMPERATURE RANGE:  $-40$  to  $+125^{\circ}\text{C}$**

### TEMPERATURE CHARACTERISTICS AND TOLERANCE

Temperature characteristics	Test temperature range	Capacitance tolerance
SL (+350 to $-1000\text{ppm}/^{\circ}\text{C}$ )	$+20$ to $+85^{\circ}\text{C}$	J ( $\pm 5\%$ )
B ( $\pm 10\%$ )	$-25$ to $+85^{\circ}\text{C}$	K ( $\pm 10\%$ )
Z5U (+22, $-56\%$ )	$+10$ to $+85^{\circ}\text{C}$	M ( $\pm 20\%$ )

### PRODUCT IDENTIFICATION

CS 80 ZU 2GA 222 M A N K A  
(1) (2) (3) (4) (5) (6) (7) (8) (9) (10)

- (1) Type
- (2) Shape
- (3) Temperature characteristics
- (4) Rated voltage
- (5) Nominal capacitance
- (6) Capacitance tolerance
- (7) For use in automobiles
- (8) Lead type
- (9) Safety standard
- (10) Halogen-free compatible product

• Conformity to RoHS Directive: This means that, in conformity with EU Directive 2002/95/EC, lead, cadmium, mercury, hexavalent chromium, and specific bromine-based flame retardants, PBB and PBDE, have not been used, except for exempted applications.

• All specifications are subject to change without notice.

## CAPACITANCE AND DIMENSIONS

Part No.	Temperature characteristics	Capacitance (pF)	Capacitance tolerance	Dimensions (mm)				Taping dimensions
				D max.	T max.	F	d	
CS45SL2GA100JA□*KA	SL (+350 to -1000ppm/°C)	10	J (±5%)	7.0	7.0	7.5±1.5	0.6±0.05	V2
CS45SL2GA150JA□*KA		15	J (±5%)	7.0	7.0	7.5±1.5	0.6±0.05	V2
CS45SL2GA220JA□*KA		22	J (±5%)	7.0	7.0	7.5±1.5	0.6±0.05	V2
CS45SL2GA330JA□*KA		33	J (±5%)	7.0	7.0	7.5±1.5	0.6±0.05	V2
CS45SL2GA470JA□*KA		47	J (±5%)	8.0	7.0	7.5±1.5	0.6±0.05	V2
CS45SL2GA680JA□*KA		68	J (±5%)	9.0	7.0	7.5±1.5	0.6±0.05	V2
CS65-B2GA101KA□*KA	B (±10%)	100	K (±10%)	7.0	7.0	7.5±1.5	0.6±0.05	V2
CS65-B2GA151KA□*KA		150	K (±10%)	7.0	7.0	7.5±1.5	0.6±0.05	V2
CS65-B2GA221KA□*KA		220	K (±10%)	7.0	7.0	7.5±1.5	0.6±0.05	V2
CS70-B2GA331KA□*KA		330	K (±10%)	7.5	7.0	7.5±1.5	0.6±0.05	V2
CS75-B2GA471KA□*KA		470	K (±10%)	9.0	7.0	7.5±1.5	0.6±0.05	V2
CS85-B2GA681KA□*KA		680	K (±10%)	9.5	7.0	7.5±1.5	0.6±0.05	V2
CS65ZU2GA102MA□*KA	Z5U (+22, -56%)	1,000	M (±20%)	7.0	7.0	7.5±1.5	0.6±0.05	V2
CS75ZU2GA152MA□*KA		1,500	M (±20%)	8.0	7.0	7.5±1.5	0.6±0.05	V2
CS80ZU2GA222MA□*KA		2,200	M (±20%)	9.5	7.0	7.5±1.5	0.6±0.05	V2
CS95ZU2GA332MA□*KA		3,300	M (±20%)	12.0	7.0	7.5±1.5	0.6±0.05	V2
CS11ZU2GA472MA□*KA		4,700	M (±20%)	13.5	7.0	7.5±1.5	0.6±0.05	V2

\* □ : Lead shape symbol

## LIST OF STANDARD LEAD SHAPES

The lead type is indicated by the letter which is the 15th character of the product name.

Example) TDK Product Name: **CS80ZU2GA222MANKA**

└ N: Lead type (Vertical kink, Short)

Dimensions in mm

	Long lead Symbol G	Short lead Symbol N	Taping Symbol V
Vertical kink			

- We recommend using a vertical kink type.
- For bulk products, we recommend a short lead type with the symbol N.

## MARKINGS

Item	Markings	Specifications	Marking examples
1. Series	CS	CS series	<p>(Marking position is reference.)</p>
2. Nominal capacitance	222	2200pF	
3. Capacitance tolerance	M	±20%	
4. Rated voltage Eac	440~X1 300~Y2	X1: AC.440V Y2: AC.300V	
5. TDK's logogram		Production base code	
6. Date code	29	2012.9*	
7. Applications	—	For use in automobiles	

(Underscore below date of production)

\* Year and month of production: last digit of year + month denoted by 1, 2, 3, 4, 5, 6, 7, 8, 9, O (October), N (November), or D (December).

\* The expression has become simplified due to a revision in the standards.

**CERTIFIED STATUS OF VARIOUS COUNTRIES**

Safety standard	Standard No.	Temperature characteristics	Insulation sub-class	Rated voltage	Approval report No.	
					Taiwan	Xiamen
BSI	BS EN60384-14	SL, B, Z5U	X1, Y2	X1: AC.440V Y2: AC.300V	KM37103	KM37103
VDE	EN 60384-14				40017930	40017930
SEV	EN 60384-14				12.0263	12.0263
SEMKO	EN 60384-14				1125249	1125249
NEMKO	EN 60384-14				P12215336	P12215336
DEMKO	EN 60384-14				D-01153	D-01153
FIMKO	EN 60384-14				FI 27399	FI 27399
IMQ	EN 60384-14				V3692	V3692
SAA	AS3250				CS6268	CS6268
UL	UL 60384-14				E37861	E37861
CSA	CAN/CSA-E60384-14				1785515	1785515
CQC	GB/T14472-1998				CQC12001082619	CQC10001052862

• Certificate numbers shall be changed owing to the revisions of the related standards.

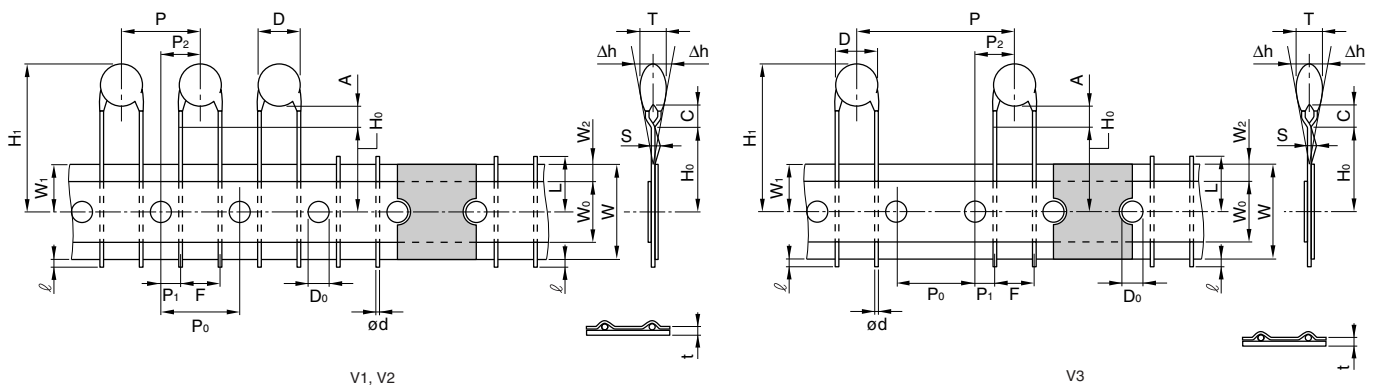
**TAPING DIMENSIONS**
**VERTICAL KINK LEAD TYPE**

Item	Symbol	Dimensions(mm)			Remarks
		V1	V2	V3	
Body diameter	D	Depends on the specification of each product.			
Body thickness	T	Depends on the specification of each product.			
Lead-wire diameter	ød	0.6±0.05	0.6±0.05	0.6±0.05	
Pitch of component	P	12.7±1.0	15.0±1.0	30.0±1.0	Including the slant of body
Feed hole pitch	P <sub>0</sub>	12.7±0.3	15.0±0.3	15.0±0.3	Excepting the tape splicing part
Feed hole center to lead	P <sub>1</sub>	3.85±0.7	3.75±0.7	3.75±0.7	
Feed hole center to component center	P <sub>2</sub>	6.35±1.3	7.5±1.3	7.5±1.3	
Lead-to lead distance	F	5+0.8, -0.2	7.5±0.8	7.5±0.8	Measuring point is bottom kink
Component alignment	Δh	0±2.0	0±2.0	0±2.0	Including the slanting body due to bending lead-wire
Tape width	W	18.0+1.0, -0.5	18.0+1.0, -0.5	18.0+1.0, -0.5	
Adhesive tape width	W <sub>0</sub>	10.0min.	10.0min.	10.0min.	
Hole position	W <sub>1</sub>	9.0±0.5	9.0±0.5	9.0±0.5	
Adhesive tape position	W <sub>2</sub>	4.0max.	4.0max.	4.0max.	Adhesive tape do not stick out the tape
Bottom of kink from tape center	H <sub>0</sub>	16.0+1.5, -0.5	16.0+1.5, -0.5	16.0+1.5, -0.5	
Height of body from tape center	H <sub>1</sub>	46.0max.	46.0max.	46.0max.	
Lead-wire protrusion	ℓ	1.0max.	1.0max.	1.0max.	
Feed hole diameter	D <sub>0</sub>	4.0±0.2	4.0±0.2	4.0±0.2	
Total tape thickness	t	0.6±0.3	0.6±0.3	0.6±0.3	Including adhesive tape
Length of snapped lead	L	11.0max.	11.0max.	11.0max.	
Coating on lead	C	4.0max.	4.0max.	4.0max.	
Height of kink	A	4.0max.	4.0max.	4.0max.	Measuring point is bottom kink
Spring action	S	2.0max.	2.0max.	2.0max.	

• For more information about products with other capacitance or other data, please contact us.

• All specifications are subject to change without notice.

# Mouser Electronics

Authorized Distributor

Click to View Pricing, Inventory, Delivery & Lifecycle Information:

## TDK:

[CS45SL2GA680JANKA](#) [CS80ZU2GA222MANKA](#) [CS11ZU2GA472MANKA](#) [CS75-B2GA471KANKA](#)  
[CS45SL2GA220JANKA](#) [CS65-B2GA221KANKA](#) [CS95ZU2GA332MANKA](#) [CS45SL2GA150JANKA](#) [CS70-](#)  
[B2GA331KANKA](#) [CS65-B2GA151KANKA](#) [CS45SL2GA470JANKA](#) [CS65ZU2GA102MANKA](#) [CS75ZU2GA152MANKA](#)  
[CS85-B2GA681KANKA](#) [CS45SL2GA100JANKA](#) [CS45SL2GA330JANKA](#) [CS65-B2GA101KANKA](#)  
[CS45SL2GA330JYNKA](#) [CS85-B2GA681KYNKA](#) [CS70-B2GA331KYNKA](#) [CS45SL2GA100JYNKA](#)  
[CS95ZU2GA332MYNKA](#) [CS45SL2GA680JYNKA](#) [CS75-B2GA471KYNKA](#) [CS11ZU2GA472MYNKA](#) [CS65-](#)  
[B2GA101KYNKA](#) [CS45SL2GA220JYNKA](#) [CS65-B2GA151KYNKA](#) [CS75ZU2GA152MYNKA](#) [CS45SL2GA150JYNKA](#)  
[CS80ZU2GA222MYNKA](#) [CS14-F2GA103MYNKA](#) [CS65-B2GA221KYNKA](#) [CS65ZU2GA102MYNKA](#)  
[CS45SL2GA470JYNKA](#) [CS65-B2GA151KAGKA](#) [CS65-B2GA101KAGKA](#) [CS11ZU2GA472MAGKA](#)  
[CS80ZU2GA222MAGKA](#) [CS70-B2GA331KAGKA](#) [CS75-B2GA471KAGKA](#) [CS65ZU2GA102MAGKA](#)  
[CS95ZU2GA332MAGKA](#) [CS65-B2GA221KAGKA](#) [CS85-B2GA681KAGKA](#) [CS75ZU2GA152MAGKA](#)  
[CS95ZU2GA332MYGKA](#) [CS85-B2GA681KYGKA](#) [CS75ZU2GA152MYGKA](#) [CS65-B2GA221KYGKA](#) [CS70-](#)  
[B2GA331KYGKA](#) [CS14-F2GA103MYGKA](#) [CS80ZU2GA222MYGKA](#) [CS65-B2GA101KYGKA](#)  
[CS11ZU2GA472MYGKA](#) [CS75-B2GA471KYGKA](#) [CS65-B2GA151KYGKA](#) [CS65ZU2GA102MYGKA](#)