

# CBTU4411

11-bit DDR2 SDRAM MUX/bus switch with 12  $\Omega$  ON resistance

Rev. 4 — 18 June 2012

Product data sheet

## 1. General description

This 11-bit bus switch is designed for 1.7 V to 1.9 V  $V_{DD}$  operation and SSTL\_18 select input levels.

Each Host port pin (HPn) is multiplexed to one of four DIMM port pins (xDPn). The selection of the DIMM port to be connected to the Host port is controlled by a decoder driven by three hardware select pins S0, S1 and  $\overline{EN}$ . Driving pin  $\overline{EN}$  HIGH disconnects all DIMM ports from their respective host ports. When  $\overline{EN}$  is driven LOW, pins S0 and S1 select one of four DIMM ports to be connected to their respective host port. When disconnected, any DIMM port is terminated to the externally supplied voltage  $V_{bias}$  by means of an on-chip pull-down resistor of typically 400  $\Omega$ . The ON-state connects the Host port to the DIMM port through a 12  $\Omega$  nominal series resistance. The design is intended to have only one DIMM port active at any time.

The CBTU4411 can also be configured to support a differential strobe signal on channel 10 (TRUE) and channel 9 (complementary Strobe). When its LVCMOS configuration input strobe enable (STREN) is HIGH, channel 10 is pulled up to  $\frac{3}{4}$  of  $V_{DD}$  internally by a resistive divider when the DIMM port is idle. When the CBTU4411 is disabled ( $\overline{EN}$  = HIGH in Strobe mode), the pull-down on channel 10 is disabled for current savings, pulling channel 10 to  $V_{DD}$ . When strobe enable (STREN) is LOW, channel 10 behaves the same as all other channels.

The select inputs (S0, S1) are pseudo-differential type SSTL\_18. A reference voltage should be provided to input pin VREF at nominally 0.5 $V_{DD}$ . This topology provides accurate control of switching times by reducing dependency on select signal slew rates. S0 and S1 are provided with selectable input termination to 0.5 $V_{DD}$  (active when LVCMOS input TERM is HIGH). When the CBTU4411 is disabled ( $\overline{EN}$  = HIGH), both S0 and S1 inputs are pulled LOW.

The part incorporates a very low crosstalk design. It has a very low skew between outputs (< 30 ps) and low skew (< 30 ps) for rising and falling edges. The part has optimal performance in DDR2 data bus applications.

Each switch has been optimized for connection to 1- or 2-rank DIMMs.

The low internal RC time constant of the switch allows data transfer to be made with minimal propagation delay.

The CBTU4411 is characterized for operation from 0  $^{\circ}$ C to +85  $^{\circ}$ C.



## 2. Features and benefits

- Enable ( $\overline{\text{EN}}$ ) and select signals (S0, S1) are SSTL\_18 compatible
- Optimized for use in Double Data Rate 2 (DDR2) SDRAM applications
- Suitable to be used with 400 Mbit/s to 800 Mbit/s, 200 MHz to 400 MHz DDR2 data bus
- Switch ON-resistance is designed to eliminate the need for series resistor to DDR2 SDRAM
- 12  $\Omega$  ON-resistance
- Controlled enable/disable times support fast bus turnaround
- Pseudo-differential select inputs support accurate and low-skew control of switching times
- Selectable built-in termination resistors on the Sn inputs
- Internal 400  $\Omega$  pull-down resistors on xDPn port
- VBIAS input for optimal DIMM-port pull-down when disabled
- Configurable to support differential strobe with pull-up to  $\frac{3}{4}$  of  $V_{\text{DD}}$  on channel 10 when idle
- Low differential skew
- Matched rise/fall slew rate
- Low crosstalk data-data/data-DQM
- Simplified 1 : 4 switch position control by 2-bit encoded input
- Single input pin puts all bus switches in OFF (high-impedance) position
- Latch-up protection exceeds 500 mA per JESD78
- ESD protection exceeds 1500 V HBM per JESD22-A114 and 750 V CDM per JESD22-C101

## 3. Ordering information

**Table 1. Ordering information**

$T_{\text{amb}} = 0\text{ }^{\circ}\text{C}$  to  $+85\text{ }^{\circ}\text{C}$ .

Type number	Package		
	Name	Description	Version
CBTU4411EE	LFBGA72	plastic low profile fine-pitch ball grid array package; 72 balls; body $7 \times 7 \times 1.05$ mm	SOT856-1

4. Functional diagram

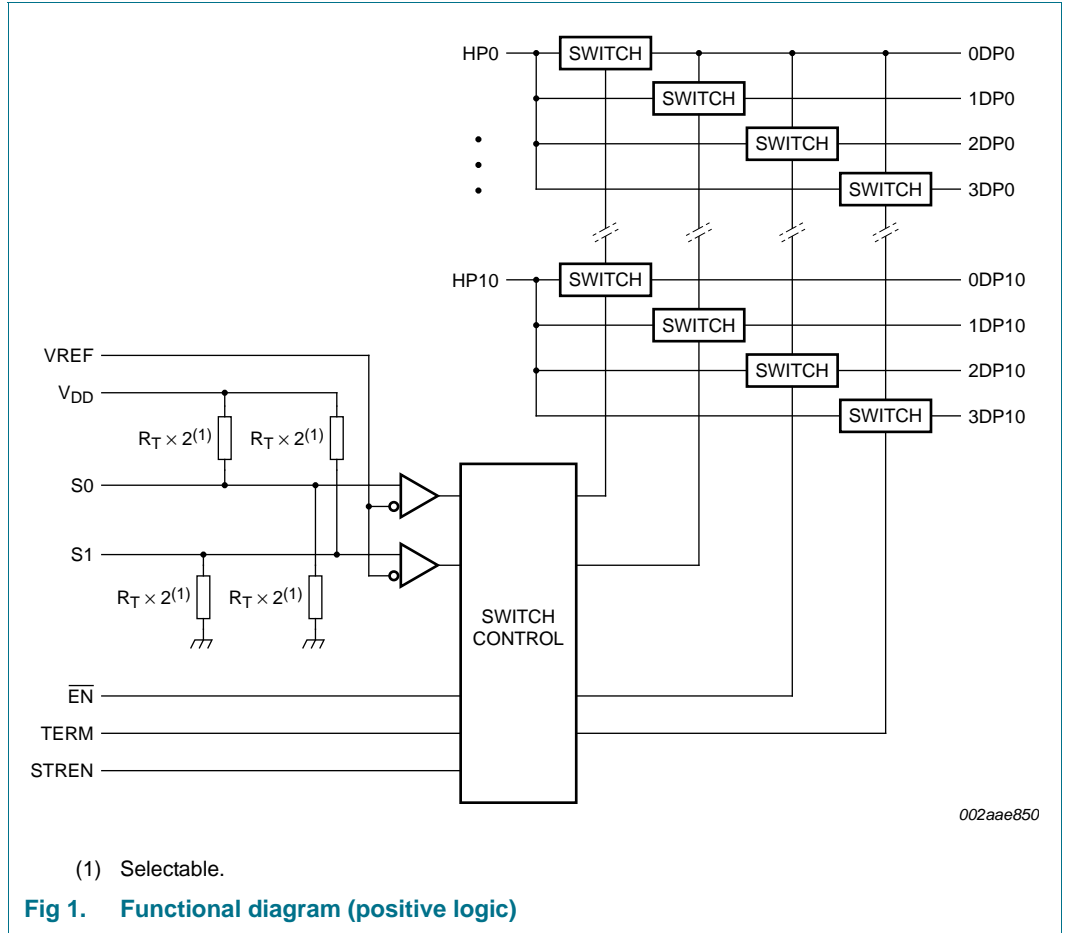

Fig 1. Functional diagram (positive logic)

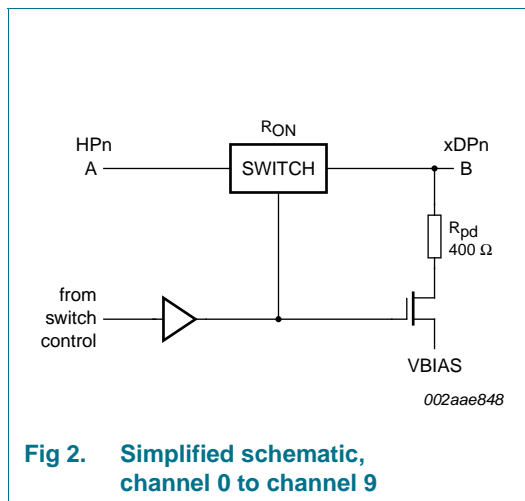

Fig 2. Simplified schematic, channel 0 to channel 9

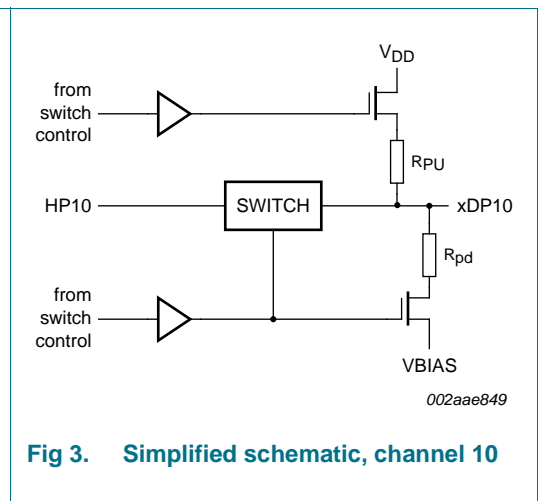
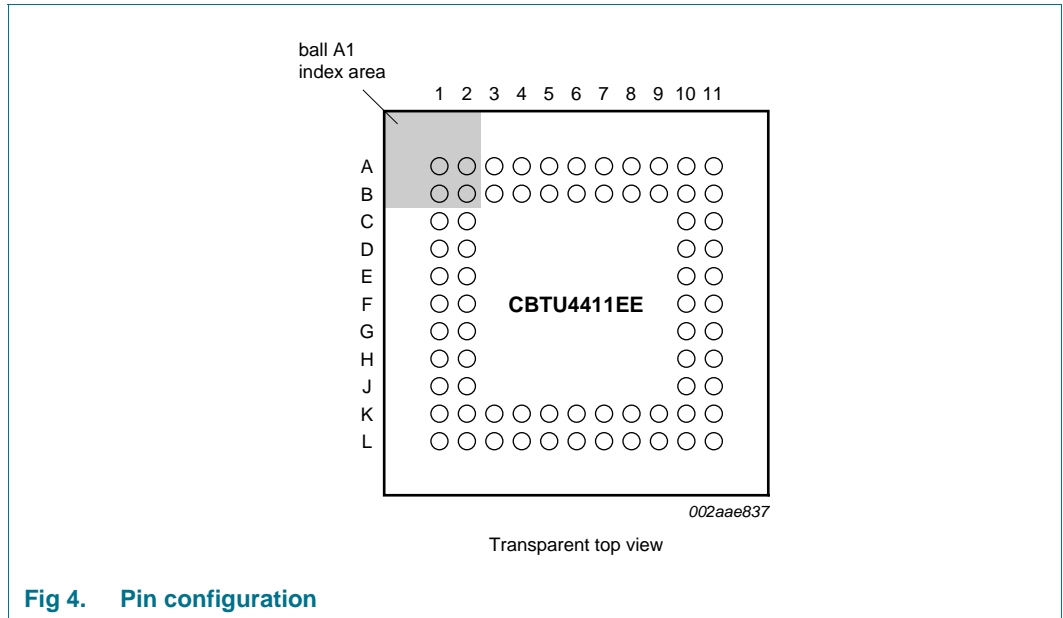

Fig 3. Simplified schematic, channel 10

## 5. Pinning information

### 5.1 Pinning



**Fig 4. Pin configuration**

	1	2	3	4	5	6	7	8	9	10	11
A	S1	STREN	V <sub>DD</sub>	ODP0	1DP0	2DP0	1DP1	2DP1	3DP1	ODP2	1DP2
B	TERM	S0	V <sub>DD</sub>	GND	HP0	3DP0	0DP1	HP1	GND	HP2	2DP2
C	VREF	$\overline{EN}$								ODP3	3DP2
D	VBIAS	GND								HP3	1DP3
E	2DP10	3DP10								2DP3	3DP3
F	1DP10	HP10								GND	0DP4
G	0DP10	GND								HP4	1DP4
H	3DP9	2DP9								2DP4	3DP4
J	1DP9	HP9								1DP5	0DP5
K	0DP9	GND	HP8	0DP8	HP7	0DP7	GND	HP6	0DP6	HP5	2DP5
L	3DP8	2DP8	1DP8	3DP7	2DP7	1DP7	3DP6	2DP6	1DP6	V <sub>DD</sub>	3DP5

*002aae838*

Blank cell indicates no ball at that location.

**Fig 5. Ball mapping (transparent top view)**

## 5.2 Pin description

**Table 2. Pin description**

Symbol	Pin	Description
HP0 to HP10	B5, B8, B10, D10, G10, K10, K8, K5, K3, J2, F2	Host ports
$\overline{\text{EN}}$	C2	LVC MOS level enable input (active LOW). When connected HIGH, all DIMM ports will be disconnected (show a high-impedance path) from the Host ports.
STREN	A2	Strobe enable. LVC MOS level strobe enable input (active HIGH). When tied LOW, channel 10 (HP10 and its DP ports) functions identically to all other channels. When tied HIGH, channel 10 is designated as the Strobe channel (see <a href="#">Section 6.1 "Function selection"</a> , <a href="#">Figure 2</a> and <a href="#">Figure 3</a> ).
S0	B2	Select inputs; type SSTL_18. See <a href="#">Section 6.1 "Function selection"</a> .
S1	A1	
VREF	C1	Reference voltage for the pseudo-differential SSTL_18 select inputs (S0, S1).
VBIAS	D1	Voltage bias for the DIMM port pull-down resistor ( $R_{pd}$ ).
TERM	B1	LVC MOS level input pin activates termination resistance on Sn inputs when HIGH; high-impedance when LOW.
ODP0, 1DP0, 2DP0, 3DP0	A4, A5, A6, B6	DIMM port 0
ODP1, 1DP1, 2DP1, 3DP1	B7, A7, A8, A9	DIMM port 1
ODP2, 1DP2, 2DP2, 3DP2	A10, A11, B11, C11	DIMM port 2
ODP3, 1DP3, 2DP3, 3DP3	C10, D11, E10, E11	DIMM port 3
ODP4, 1DP4, 2DP4, 3DP4	F11, G11, H10, H11	DIMM port 4
ODP5, 1DP5, 2DP5, 3DP5	J11, J10, K11, L11	DIMM port 5
ODP6, 1DP6, 2DP6, 3DP6	K9, L9, L8, L7	DIMM port 6
ODP7, 1DP7, 2DP7, 3DP7	K6, L6, L5, L4	DIMM port 7
ODP8, 1DP8, 2DP8, 3DP8	K4, L3, L2, L1	DIMM port 8
ODP9, 1DP9, 2DP9, 3DP9	K1, J1, H2, H1	DIMM port 9
ODP10, 1DP10, 2DP10, 3DP10	G1, F1, E1, E2	DIMM port 10
GND	B4, B9, D2, F10, G2, K2, K7	Ground
V <sub>DD</sub>	A3, B3, L10	Positive supply voltage

## 6. Functional description

Refer to [Figure 1 “Functional diagram \(positive logic\)”](#).

### 6.1 Function selection

**Table 3. Function selection, channel 0 to channel 9**

*H = HIGH voltage level; L = LOW voltage level; high-Z = high-impedance; X = Don't care.*

Inputs			Function							
EN	S1	S0	0DPn		1DPn		2DPn		3DPn	
			HPn	VBIAS	HPn	VBIAS	HPn	VBIAS	HPn	VBIAS
L	L	L	R <sub>ON</sub>	high-Z	high-Z	R <sub>pd</sub>	high-Z	R <sub>pd</sub>	high-Z	R <sub>pd</sub>
L	L	H	high-Z	R <sub>pd</sub>	R <sub>ON</sub>	high-Z	high-Z	R <sub>pd</sub>	high-Z	R <sub>pd</sub>
L	H	L	high-Z	R <sub>pd</sub>	high-Z	R <sub>pd</sub>	R <sub>ON</sub>	high-Z	high-Z	R <sub>pd</sub>
L	H	H	high-Z	R <sub>pd</sub>	high-Z	R <sub>pd</sub>	high-Z	R <sub>pd</sub>	R <sub>ON</sub>	high-Z
H	X	X	high-Z	R <sub>pd</sub>	high-Z	R <sub>pd</sub>	high-Z	R <sub>pd</sub>	high-Z	R <sub>pd</sub>

**Table 4. Function selection, channel 10**

H = HIGH voltage level; L = LOW voltage level; high-Z = high-impedance; X = Don't care.

Inputs				Function											
				ODP10			1DP10			2DP10			3DP10		
EN	S1	S0	STREN	HP10	VBIAS	V <sub>DD</sub>	HP10	VBIAS	V <sub>DD</sub>	HP10	VBIAS	V <sub>DD</sub>	HP10	VBIAS	V <sub>DD</sub>
L	L	L	L	R <sub>ON</sub>	high-Z	high-Z	high-Z	R <sub>pd</sub>	high-Z	high-Z	R <sub>pd</sub>	high-Z	high-Z	R <sub>pd</sub>	high-Z
L	L	L	H	R <sub>ON</sub>	high-Z	high-Z	high-Z	R <sub>pd</sub>	R <sub>PU</sub>	high-Z	R <sub>pd</sub>	R <sub>PU</sub>	high-Z	R <sub>pd</sub>	R <sub>PU</sub>
L	L	H	L	high-Z	R <sub>pd</sub>	high-Z	R <sub>ON</sub>	high-Z	high-Z	high-Z	R <sub>pd</sub>	high-Z	high-Z	R <sub>pd</sub>	high-Z
L	L	H	H	high-Z	R <sub>pd</sub>	R <sub>PU</sub>	R <sub>ON</sub>	high-Z	high-Z	high-Z	R <sub>pd</sub>	R <sub>PU</sub>	high-Z	R <sub>pd</sub>	R <sub>PU</sub>
L	H	L	L	high-Z	R <sub>pd</sub>	high-Z	high-Z	R <sub>pd</sub>	high-Z	R <sub>ON</sub>	high-Z	high-Z	high-Z	R <sub>pd</sub>	high-Z
L	H	L	H	high-Z	R <sub>pd</sub>	R <sub>PU</sub>	high-Z	R <sub>pd</sub>	R <sub>PU</sub>	R <sub>ON</sub>	high-Z	high-Z	high-Z	R <sub>pd</sub>	R <sub>PU</sub>
L	H	H	L	high-Z	R <sub>pd</sub>	high-Z	high-Z	R <sub>pd</sub>	high-Z	high-Z	R <sub>pd</sub>	high-Z	R <sub>ON</sub>	high-Z	high-Z
L	H	H	H	high-Z	R <sub>pd</sub>	R <sub>PU</sub>	high-Z	R <sub>pd</sub>	R <sub>PU</sub>	high-Z	R <sub>pd</sub>	R <sub>PU</sub>	R <sub>ON</sub>	high-Z	high-Z
H	X	X	L	high-Z	R <sub>pd</sub>	high-Z	high-Z	R <sub>pd</sub>	high-Z	high-Z	R <sub>pd</sub>	high-Z	high-Z	R <sub>pd</sub>	high-Z
H	X	X	H	high-Z	high-Z	R <sub>PU</sub>	high-Z	high-Z	R <sub>PU</sub>	high-Z	high-Z	R <sub>PU</sub>	high-Z	high-Z	R <sub>PU</sub>

**Table 5. S0, S1 input termination**

H = HIGH voltage level; L = LOW voltage level; X = Don't care.

EN	TERM	Sn input termination
L	L	Termination resistors on S0, S1 inputs disconnected (high-impedance).
L	H	Termination resistors on S0, S1 inputs active.
H	X	Pull-down to GND via $R_T \times 2$ . Also disables the S0, S1 input receivers for power savings.

## 7. Limiting values

**Table 6. Limiting values**

In accordance with the Absolute Maximum Rating System (IEC 60134).

The package thermal impedance is calculated in accordance with JESD 51.

Symbol	Parameter	Conditions	Min	Max	Unit
$V_{DD}$	supply voltage		-0.5	+2.5	V
$I_{IK}$	input clamping current	$V_{I/O} < 0$ V	-	-50	mA
$V_I$	input voltage	S0, S1 pins only	[1] -	$V_{DD} + 0.3$	V
		except S0, S1 pins	[1] -0.5	+2.5	V
$T_{stg}$	storage temperature		-65	+150	$^{\circ}$ C

[1] The input and output negative voltage ratings may be exceeded if the input and output clamping current ratings are observed.

## 8. Recommended operating conditions

**Table 7. Operating conditions**

All unused control inputs of the device must be held at  $V_{DD}$  or GND to ensure proper device operation.

Symbol	Parameter	Conditions	Min	Typ	Max	Unit
$V_{DD}$	supply voltage		1.7	-	1.9	V
$V_{ref}$	reference voltage		$0.49 \times V_{DD}$	$0.50 \times V_{DD}$	$0.51 \times V_{DD}$	V
$V_{bias}$	bias voltage	pull-down resistor input	[1] 0	$0.30 \times V_{DD}$	$0.33 \times V_{DD}$	V
$V_T$	termination voltage		$V_{ref} - 0.04$	$V_{ref}$	$V_{ref} + 0.04$	V
$V_i$	input voltage		0	-	$V_{DD}$	V
$V_{IH(AC)}$	AC HIGH-level input voltage	S0, S1 inputs	$V_{ref} + 0.250$	-	-	V
$V_{IL(AC)}$	AC LOW-level input voltage	S0, S1 inputs	-	-	$V_{ref} - 0.250$	V
$V_{IH(DC)}$	DC HIGH-level input voltage	S0, S1 inputs	$V_{ref} + 0.125$	-	-	V
$V_{IL(DC)}$	DC LOW-level input voltage	S0, S1 inputs	-	-	$V_{ref} - 0.125$	V
$V_{IH}$	HIGH-level input voltage	$\overline{EN}$ , STREN, TERM pins	$0.65 \times V_{DD}$	-	-	V
$V_{IL}$	LOW-level input voltage	$\overline{EN}$ , STREN, TERM pins	-	-	$0.35 \times V_{DD}$	V
$T_{amb}$	ambient temperature	operating in free air	0	-	+85	$^{\circ}$ C

[1]  $V_{bias} > 0.5 \times V_{DD}$  is reserved for test purposes only.



## 9. Static characteristics

**Table 8. Static characteristics**

$T_{amb} = 0\text{ }^{\circ}\text{C to }+85\text{ }^{\circ}\text{C}$

Symbol	Parameter	Conditions	Min	Typ <sup>[1]</sup>	Max	Unit
$V_{IK}$	input clamping voltage	$V_{DD} = 1.7\text{ V}$ ; $I_I = -18\text{ mA}$	-	-	-1.2	V
$V_T$	termination voltage	on S0, S1 inputs when Sn = open circuit and TERM = HIGH	$0.5V_{DD} - 0.04$	$0.5V_{DD}$	$0.5V_{DD} + 0.04$	V
$V_{pu}$	pull-up voltage	channel 10 DIMM port; EN = LOW; $V_{bias} = 0.54\text{ V}$ ; $V_{DD} = 1.8\text{ V}$ ; STREN = HIGH; unselected DIMM port	$0.5V_{DD} + 0.25$	$0.75V_{DD}$	$0.75V_{DD} + 0.25$	V
$I_{LI}$	input leakage current	$V_{DD} = 1.8\text{ V}$ ; $V_I = V_{DD}$ or GND; Sn = $V_{DD}$ ; $V_{bias} = V_{DD}$ ; TERM = LOW				
		S0, S1	-	-	$\pm 100$	$\mu\text{A}$
		host port	-	-	$\pm 100$	$\mu\text{A}$
		DIMM port	-	-	$\pm 100$	$\mu\text{A}$
$I_{DD}$	supply current	$V_{DD} = 1.8\text{ V}$ ; $I_O = 0\text{ A}$ ; $V_I = V_{DD}$ or GND				
		$\overline{\text{EN}} = \text{LOW}$	-	6	9	mA
		$\overline{\text{EN}} = \text{HIGH}$	-	5	100	$\mu\text{A}$
$C_{in}$	input capacitance	S0, S1 pins; $V_I = 1.8\text{ V}$ or $0\text{ V}$	-	3	-	pF
$C_{sw}$	switch capacitance	switch ON; $V_I = 0.9\text{ V}$	-	4	6	pF
$R_{ON}$	ON resistance	$V_{DD} = 1.8\text{ V}$ ; $V_{HPn} = V_{ref}$ ; $V_{xDPn} = V_{ref} \pm 250\text{ mV}$	<sup>[2]</sup> 10	12	17	$\Omega$
		$V_{DD} = 1.8\text{ V}$ ; $V_{HPn} = V_{ref}$ ; $V_{xDPn} = V_{ref} \pm 500\text{ mV}$	<sup>[2]</sup> 10	12	17	$\Omega$
$R_{pd}$	pull-down resistance	$\overline{\text{EN}} = \text{HIGH}$ ; $V_{bias} = 0.54\text{ V}$ ; $V_{DD} = 1.8\text{ V}$	280	400	520	$\Omega$
		channel 10; STREN = LOW	280	400	520	$\Omega$
		channel 10; STREN = HIGH	780	1120	1460	$\Omega$
$R_{PU}$	pull-up resistance	$\overline{\text{EN}} = \text{HIGH}$ ; $V_{bias} = 0.54\text{ V}$ ; $V_{DD} = 1.8\text{ V}$ ; channel 10; STREN = HIGH	430	622	810	$\Omega$
$R_T$	termination resistance	Sn input; Thevenin equivalent (see Figure 1); input voltage sweep $0 < V_I (\text{Sn}) < V_{DD}$ ; TERM = HIGH	55	80	105	$\Omega$

[1] All typical values are at  $V_{DD} = 1.8\text{ V}$ ,  $T_{amb} = 25\text{ }^{\circ}\text{C}$ .

[2] Measured by the current between the host and the DIMM terminals at the indicated voltages on each side of the switch.

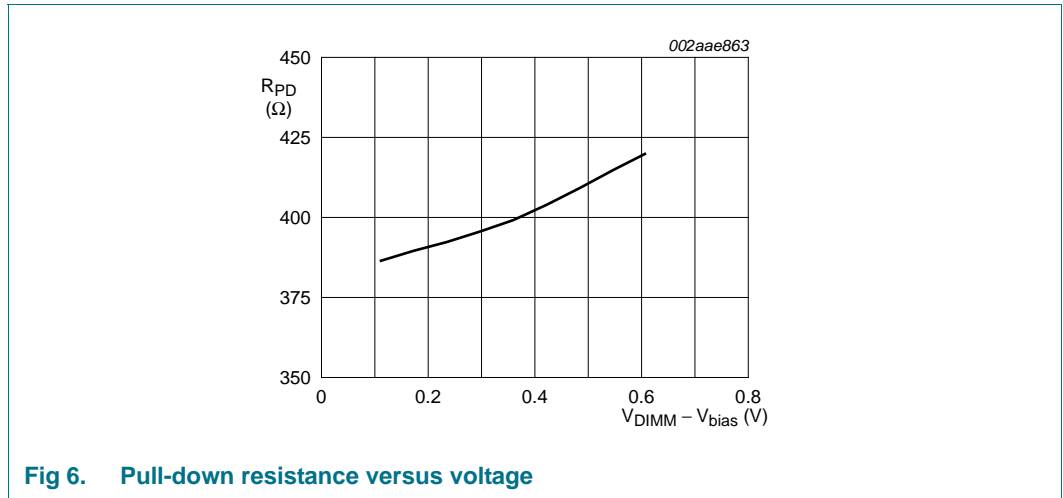

Fig 6. Pull-down resistance versus voltage

## 10. Dynamic characteristics

Table 9. Dynamic characteristics

V<sub>DD</sub> = 1.8 V ± 0.1 V.

Symbol	Parameter	Conditions	Min	Typ	Max	Unit
t <sub>PD</sub>	propagation delay	from HPn or xDPn to xDPn or HPn; <a href="#">Figure 9</a> , <a href="#">Figure 13</a>	[1] -	50	100	ps
t <sub>PZH</sub>	driver enable delay to HIGH level	from Sn to HPn or xDPn	0.75	-	1.75	ns
t <sub>PZL</sub>	driver enable delay to LOW level	from Sn to HPn or xDPn	0.75	-	1.75	ns
t <sub>PHZ</sub>	driver disable delay from HIGH level	from Sn to HPn or xDPn	0.75	-	1.75	ns
t <sub>PLZ</sub>	driver disable delay from LOW level	from Sn to HPn or xDPn	0.75	-	1.75	ns
t <sub>sk(o)</sub>	output skew time	from any output to any output; <a href="#">Figure 12</a>	[2] -	25	30	ps
t <sub>sk(edge)</sub>	edge skew time	<a href="#">Figure 11</a>	[2][3] -	25	30	ps

[1] This parameter is not production tested.

[2] Skew is not production tested.

[3] Difference of rising edge propagation delay to falling edge propagation delay.

11. HPn to xDPn AC waveforms and test circuit

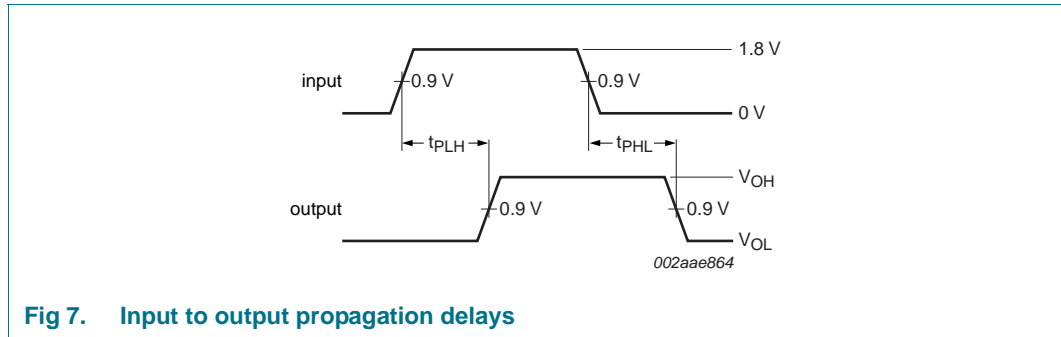
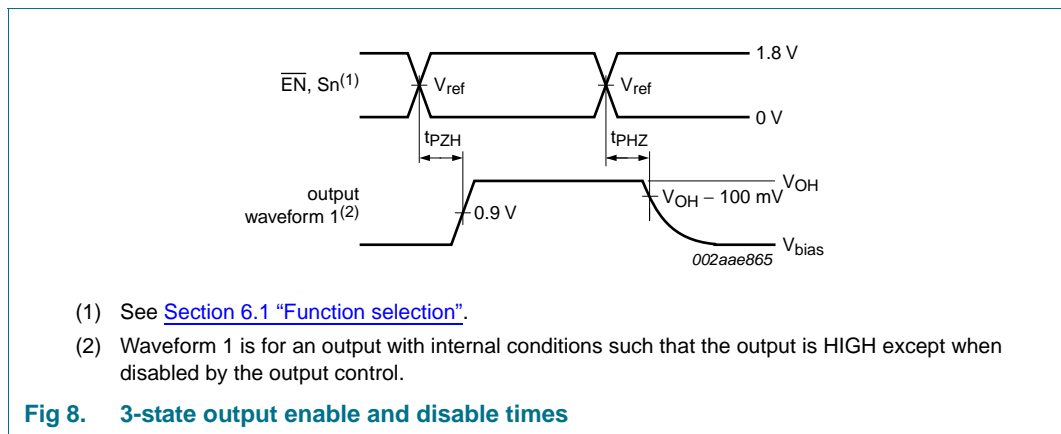
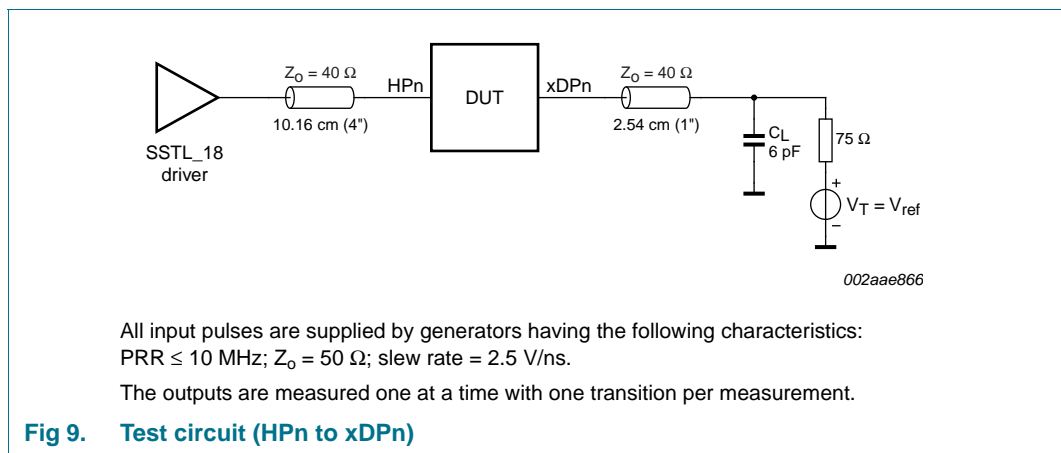

Fig 7. Input to output propagation delays



- (1) See [Section 6.1 "Function selection"](#).
- (2) Waveform 1 is for an output with internal conditions such that the output is HIGH except when disabled by the output control.

Fig 8. 3-state output enable and disable times



All input pulses are supplied by generators having the following characteristics:  
 PRR ≤ 10 MHz; Z<sub>o</sub> = 50 Ω; slew rate = 2.5 V/ns.  
 The outputs are measured one at a time with one transition per measurement.

Fig 9. Test circuit (HPn to xDPn)

### 12. xDPn to HPn AC waveforms and test circuit

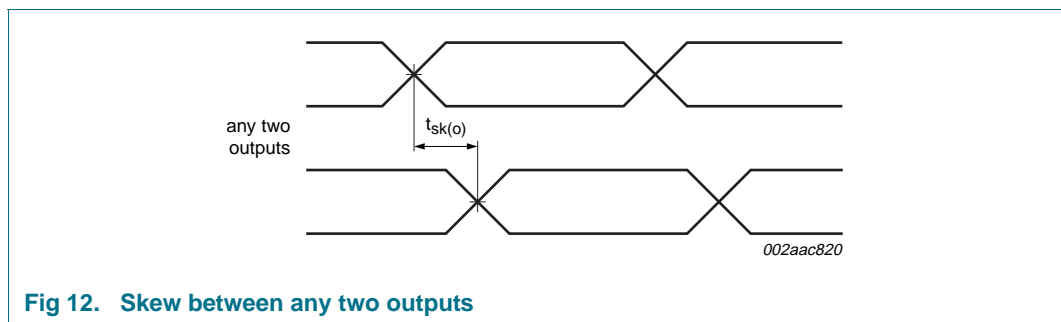
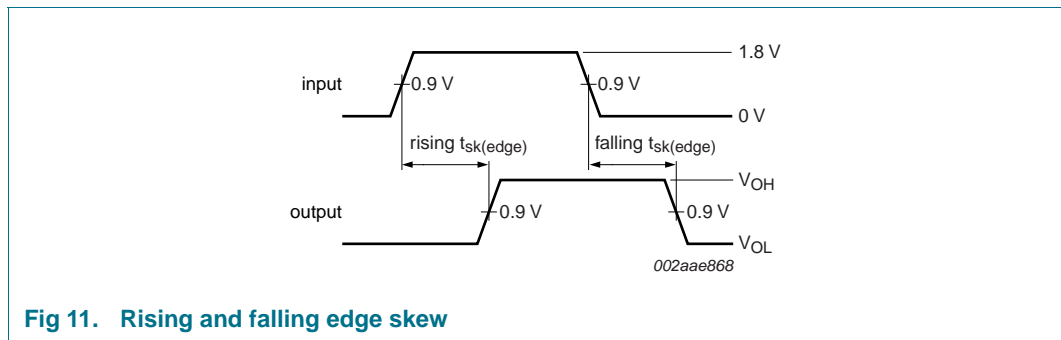
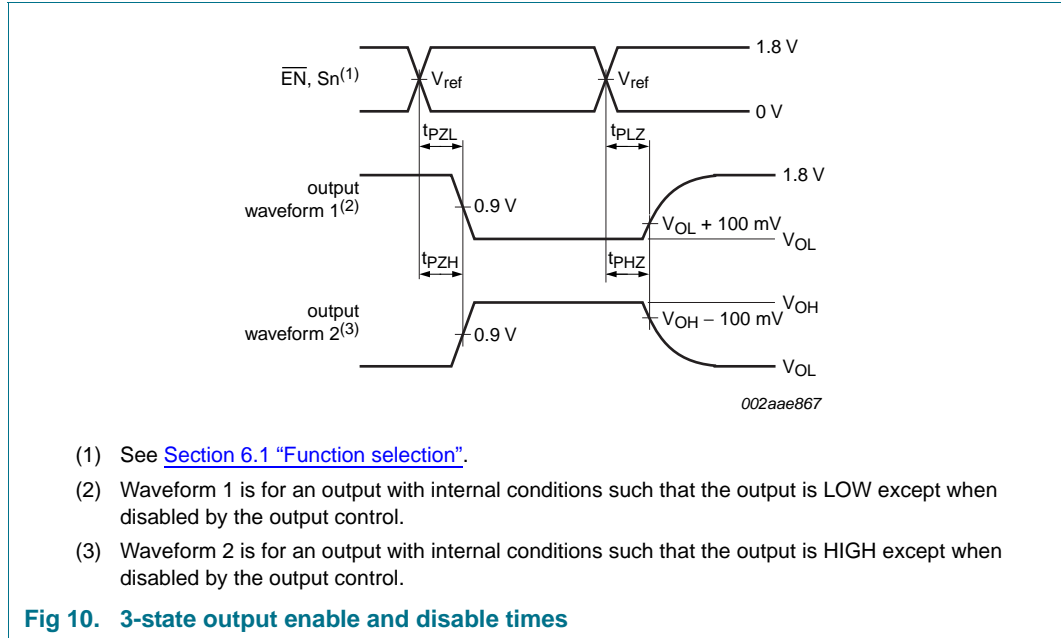

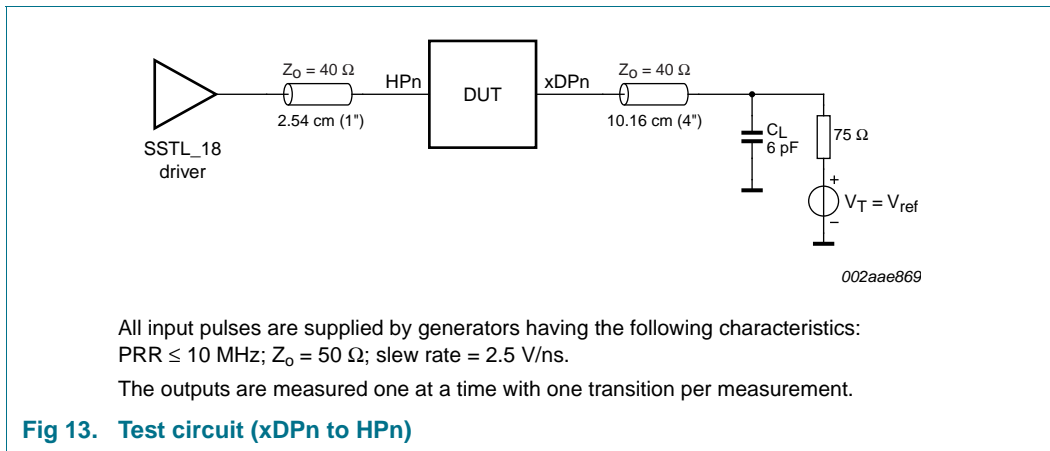

### 13. Test information

**Table 10.  $I_{DD}$  test mode**

Condition	Description
$V_{bias} = V_{DD}$	All DIMM ports are disconnected (high-impedance) from their host ports, and disconnected (high-impedance) from VBIAS and $R_{PU}$ . Used for production testing only.
$V_{bias} < 0.5V_{DD}$	Normal operation. See <a href="#">Section 6.1 "Function selection"</a> .

### 14. Package outline

LFBGA72: plastic low profile fine-pitch ball grid array package; 72 balls; body 7 x 7 x 1.05 mm

SOT856-1

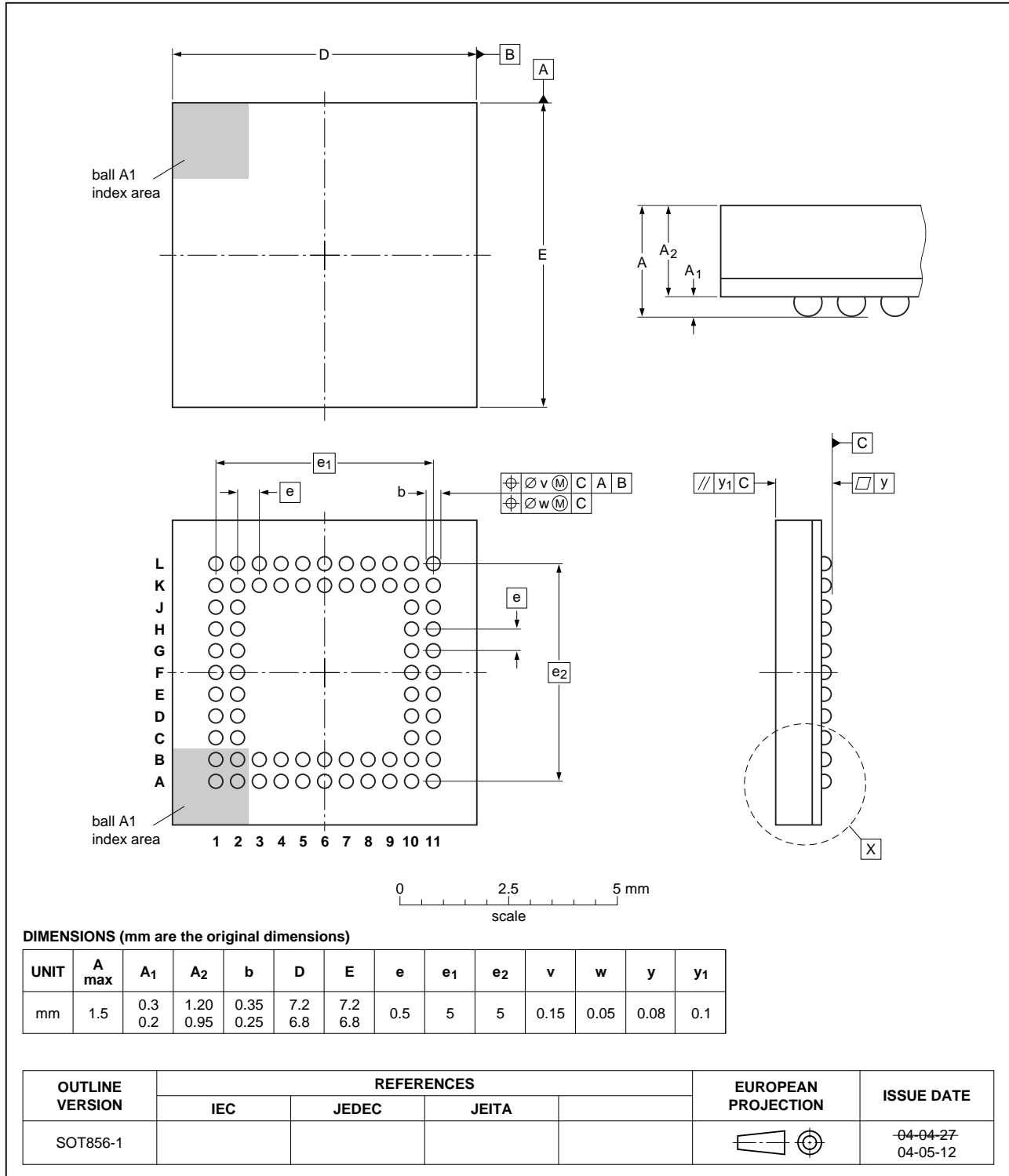

Fig 14. Package outline SOT856-1 (LFBGA72)

## 15. Soldering of SMD packages

This text provides a very brief insight into a complex technology. A more in-depth account of soldering ICs can be found in Application Note AN10365 “Surface mount reflow soldering description”.

### 15.1 Introduction to soldering

Soldering is one of the most common methods through which packages are attached to Printed Circuit Boards (PCBs), to form electrical circuits. The soldered joint provides both the mechanical and the electrical connection. There is no single soldering method that is ideal for all IC packages. Wave soldering is often preferred when through-hole and Surface Mount Devices (SMDs) are mixed on one printed wiring board; however, it is not suitable for fine pitch SMDs. Reflow soldering is ideal for the small pitches and high densities that come with increased miniaturization.

### 15.2 Wave and reflow soldering

Wave soldering is a joining technology in which the joints are made by solder coming from a standing wave of liquid solder. The wave soldering process is suitable for the following:

- Through-hole components
- Leaded or leadless SMDs, which are glued to the surface of the printed circuit board

Not all SMDs can be wave soldered. Packages with solder balls, and some leadless packages which have solder lands underneath the body, cannot be wave soldered. Also, leaded SMDs with leads having a pitch smaller than  $\sim 0.6$  mm cannot be wave soldered, due to an increased probability of bridging.

The reflow soldering process involves applying solder paste to a board, followed by component placement and exposure to a temperature profile. Leaded packages, packages with solder balls, and leadless packages are all reflow solderable.

Key characteristics in both wave and reflow soldering are:

- Board specifications, including the board finish, solder masks and vias
- Package footprints, including solder thieves and orientation
- The moisture sensitivity level of the packages
- Package placement
- Inspection and repair
- Lead-free soldering versus SnPb soldering

### 15.3 Wave soldering

Key characteristics in wave soldering are:

- Process issues, such as application of adhesive and flux, clinching of leads, board transport, the solder wave parameters, and the time during which components are exposed to the wave
- Solder bath specifications, including temperature and impurities

### 15.4 Reflow soldering

Key characteristics in reflow soldering are:

- Lead-free versus SnPb soldering; note that a lead-free reflow process usually leads to higher minimum peak temperatures (see [Figure 15](#)) than a SnPb process, thus reducing the process window
- Solder paste printing issues including smearing, release, and adjusting the process window for a mix of large and small components on one board
- Reflow temperature profile; this profile includes preheat, reflow (in which the board is heated to the peak temperature) and cooling down. It is imperative that the peak temperature is high enough for the solder to make reliable solder joints (a solder paste characteristic). In addition, the peak temperature must be low enough that the packages and/or boards are not damaged. The peak temperature of the package depends on package thickness and volume and is classified in accordance with [Table 11](#) and [12](#)

**Table 11. SnPb eutectic process (from J-STD-020C)**

Package thickness (mm)	Package reflow temperature (°C)	
	Volume (mm <sup>3</sup> )	
	< 350	≥ 350
< 2.5	235	220
≥ 2.5	220	220

**Table 12. Lead-free process (from J-STD-020C)**

Package thickness (mm)	Package reflow temperature (°C)		
	Volume (mm <sup>3</sup> )		
	< 350	350 to 2000	> 2000
< 1.6	260	260	260
1.6 to 2.5	260	250	245
> 2.5	250	245	245

Moisture sensitivity precautions, as indicated on the packing, must be respected at all times.

Studies have shown that small packages reach higher temperatures during reflow soldering, see [Figure 15](#).



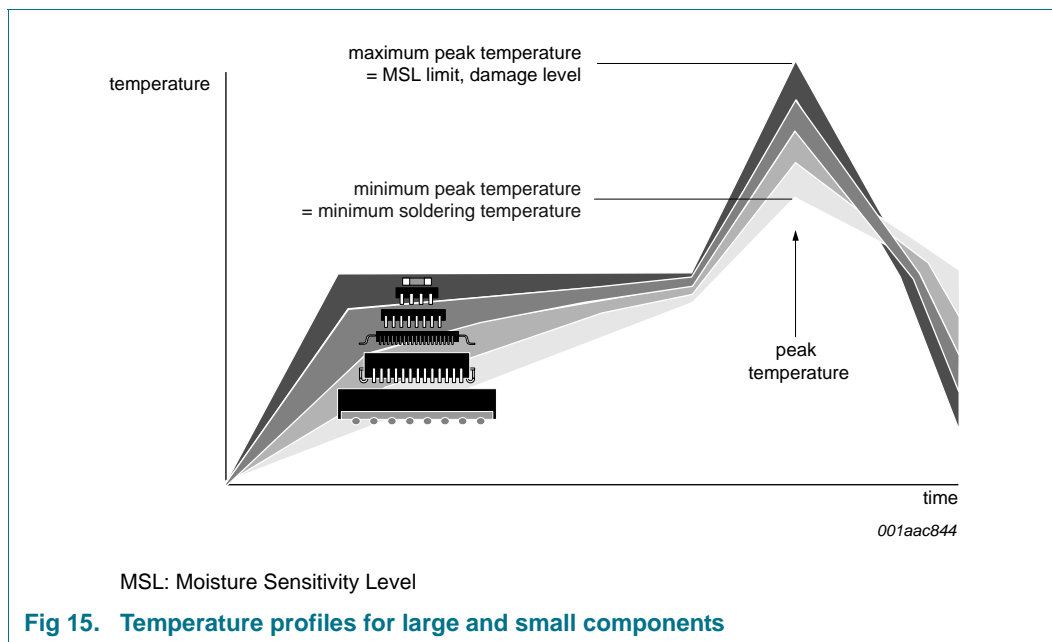

For further information on temperature profiles, refer to Application Note AN10365 “Surface mount reflow soldering description”.

## 16. Abbreviations

**Table 13. Abbreviations**

Acronym	Description
CDM	Charged-Device Model
DDR2	Double Data Rate 2
DIMM	Dual In-Line Memory Module
DQM	Data Queue Mask
ESD	ElectroStatic Discharge
HBM	Human Body Model
LVC MOS	Low Voltage Complementary Metal-Oxide Semiconductor
MUX	Multiplexer
PRR	Pulse Repetition Rate
RC	Resistor-Capacitor network
SDRAM	Synchronous Dynamic Random Access Memory
SSTL_18	Stub Series Terminated Logic for 1.8 V

## 17. Revision history

Table 14. Revision history

Document ID	Release date	Data sheet status	Change notice	Supersedes
CBTU4411 v.4	20120618	Product data sheet	-	CBTU4411 v.3
Modifications:	<ul style="list-style-type: none"> <li>• <a href="#">Section 2 "Features and benefits"</a>, 18th bullet item: removed phrase "200 V MM per JESD22-A115"</li> <li>• <a href="#">Table 8 "Static characteristics"</a>: <ul style="list-style-type: none"> <li>– Symbol/Parameter "C<sub>on</sub>, switch on capacitance" changed to "C<sub>sw</sub>, switch capacitance" (and placed "switch ON" under Conditions)</li> <li>– R<sub>ON</sub> Min value for Condition "V<sub>xDPn</sub> = V<sub>ref</sub> ± 250 mV" changed from "7 <math>\Omega</math>" to "10 <math>\Omega</math>"</li> <li>– R<sub>ON</sub> Min value for Condition "V<sub>xDPn</sub> = V<sub>ref</sub> ± 500 mV" changed from "7 <math>\Omega</math>" to "10 <math>\Omega</math>"</li> <li>– deleted <math>\Delta R_{ON}</math> row</li> </ul> </li> <li>• <a href="#">Table 13 "Abbreviations"</a>: removed "MM" from list of acronyms</li> </ul>			
CBTU4411 v.3	20091012	Product data sheet	-	CBTU4411 v.2
CBTU4411 v.2	20060922	Product data sheet	-	CBTU4411 v.1
CBTU4411 v.1 (9397 750 12977)	20050107	Product data sheet	-	-

## 18. Legal information

### 18.1 Data sheet status

Document status <sup>[1][2]</sup>	Product status <sup>[3]</sup>	Definition
Objective [short] data sheet	Development	This document contains data from the objective specification for product development.
Preliminary [short] data sheet	Qualification	This document contains data from the preliminary specification.
Product [short] data sheet	Production	This document contains the product specification.

[1] Please consult the most recently issued document before initiating or completing a design.

[2] The term 'short data sheet' is explained in section "Definitions".

[3] The product status of device(s) described in this document may have changed since this document was published and may differ in case of multiple devices. The latest product status information is available on the Internet at URL <http://www.nxp.com>.

### 18.2 Definitions

**Draft** — The document is a draft version only. The content is still under internal review and subject to formal approval, which may result in modifications or additions. NXP Semiconductors does not give any representations or warranties as to the accuracy or completeness of information included herein and shall have no liability for the consequences of use of such information.

**Short data sheet** — A short data sheet is an extract from a full data sheet with the same product type number(s) and title. A short data sheet is intended for quick reference only and should not be relied upon to contain detailed and full information. For detailed and full information see the relevant full data sheet, which is available on request via the local NXP Semiconductors sales office. In case of any inconsistency or conflict with the short data sheet, the full data sheet shall prevail.

**Product specification** — The information and data provided in a Product data sheet shall define the specification of the product as agreed between NXP Semiconductors and its customer, unless NXP Semiconductors and customer have explicitly agreed otherwise in writing. In no event however, shall an agreement be valid in which the NXP Semiconductors product is deemed to offer functions and qualities beyond those described in the Product data sheet.

### 18.3 Disclaimers

**Limited warranty and liability** — Information in this document is believed to be accurate and reliable. However, NXP Semiconductors does not give any representations or warranties, expressed or implied, as to the accuracy or completeness of such information and shall have no liability for the consequences of use of such information. NXP Semiconductors takes no responsibility for the content in this document if provided by an information source outside of NXP Semiconductors.

In no event shall NXP Semiconductors be liable for any indirect, incidental, punitive, special or consequential damages (including - without limitation - lost profits, lost savings, business interruption, costs related to the removal or replacement of any products or rework charges) whether or not such damages are based on tort (including negligence), warranty, breach of contract or any other legal theory.

Notwithstanding any damages that customer might incur for any reason whatsoever, NXP Semiconductors' aggregate and cumulative liability towards customer for the products described herein shall be limited in accordance with the *Terms and conditions of commercial sale* of NXP Semiconductors.

**Right to make changes** — NXP Semiconductors reserves the right to make changes to information published in this document, including without limitation specifications and product descriptions, at any time and without notice. This document supersedes and replaces all information supplied prior to the publication hereof.

**Suitability for use** — NXP Semiconductors products are not designed, authorized or warranted to be suitable for use in life support, life-critical or safety-critical systems or equipment, nor in applications where failure or malfunction of an NXP Semiconductors product can reasonably be expected to result in personal injury, death or severe property or environmental damage. NXP Semiconductors and its suppliers accept no liability for inclusion and/or use of NXP Semiconductors products in such equipment or applications and therefore such inclusion and/or use is at the customer's own risk.

**Applications** — Applications that are described herein for any of these products are for illustrative purposes only. NXP Semiconductors makes no representation or warranty that such applications will be suitable for the specified use without further testing or modification.

Customers are responsible for the design and operation of their applications and products using NXP Semiconductors products, and NXP Semiconductors accepts no liability for any assistance with applications or customer product design. It is customer's sole responsibility to determine whether the NXP Semiconductors product is suitable and fit for the customer's applications and products planned, as well as for the planned application and use of customer's third party customer(s). Customers should provide appropriate design and operating safeguards to minimize the risks associated with their applications and products.

NXP Semiconductors does not accept any liability related to any default, damage, costs or problem which is based on any weakness or default in the customer's applications or products, or the application or use by customer's third party customer(s). Customer is responsible for doing all necessary testing for the customer's applications and products using NXP Semiconductors products in order to avoid a default of the applications and the products or of the application or use by customer's third party customer(s). NXP does not accept any liability in this respect.

**Limiting values** — Stress above one or more limiting values (as defined in the Absolute Maximum Ratings System of IEC 60134) will cause permanent damage to the device. Limiting values are stress ratings only and (proper) operation of the device at these or any other conditions above those given in the Recommended operating conditions section (if present) or the Characteristics sections of this document is not warranted. Constant or repeated exposure to limiting values will permanently and irreversibly affect the quality and reliability of the device.

**Terms and conditions of commercial sale** — NXP Semiconductors products are sold subject to the general terms and conditions of commercial sale, as published at <http://www.nxp.com/profile/terms>, unless otherwise agreed in a valid written individual agreement. In case an individual agreement is concluded only the terms and conditions of the respective agreement shall apply. NXP Semiconductors hereby expressly objects to applying the customer's general terms and conditions with regard to the purchase of NXP Semiconductors products by customer.

**No offer to sell or license** — Nothing in this document may be interpreted or construed as an offer to sell products that is open for acceptance or the grant, conveyance or implication of any license under any copyrights, patents or other industrial or intellectual property rights.

**Export control** — This document as well as the item(s) described herein may be subject to export control regulations. Export might require a prior authorization from competent authorities.

**Non-automotive qualified products** — Unless this data sheet expressly states that this specific NXP Semiconductors product is automotive qualified, the product is not suitable for automotive use. It is neither qualified nor tested in accordance with automotive testing or application requirements. NXP Semiconductors accepts no liability for inclusion and/or use of non-automotive qualified products in automotive equipment or applications.

In the event that customer uses the product for design-in and use in automotive applications to automotive specifications and standards, customer (a) shall use the product without NXP Semiconductors' warranty of the product for such automotive applications, use and specifications, and (b) whenever customer uses the product for automotive applications beyond

NXP Semiconductors' specifications such use shall be solely at customer's own risk, and (c) customer fully indemnifies NXP Semiconductors for any liability, damages or failed product claims resulting from customer design and use of the product for automotive applications beyond NXP Semiconductors' standard warranty and NXP Semiconductors' product specifications.

**Translations** — A non-English (translated) version of a document is for reference only. The English version shall prevail in case of any discrepancy between the translated and English versions.

## 18.4 Trademarks

Notice: All referenced brands, product names, service names and trademarks are the property of their respective owners.

## 19. Contact information

For more information, please visit: <http://www.nxp.com>

For sales office addresses, please send an email to: [salesaddresses@nxp.com](mailto:salesaddresses@nxp.com)

## 20. Contents

<b>1</b>	<b>General description</b> . . . . .	<b>1</b>
<b>2</b>	<b>Features and benefits</b> . . . . .	<b>2</b>
<b>3</b>	<b>Ordering information</b> . . . . .	<b>2</b>
<b>4</b>	<b>Functional diagram</b> . . . . .	<b>3</b>
<b>5</b>	<b>Pinning information</b> . . . . .	<b>4</b>
5.1	Pinning . . . . .	4
5.2	Pin description . . . . .	5
<b>6</b>	<b>Functional description</b> . . . . .	<b>6</b>
6.1	Function selection . . . . .	6
<b>7</b>	<b>Limiting values</b> . . . . .	<b>8</b>
<b>8</b>	<b>Recommended operating conditions</b> . . . . .	<b>8</b>
<b>9</b>	<b>Static characteristics</b> . . . . .	<b>9</b>
<b>10</b>	<b>Dynamic characteristics</b> . . . . .	<b>10</b>
<b>11</b>	<b>HPn to xDPn AC waveforms and test circuit</b> . . . . .	<b>11</b>
<b>12</b>	<b>xDPn to HPn AC waveforms and test circuit</b> . . . . .	<b>12</b>
<b>13</b>	<b>Test information</b> . . . . .	<b>13</b>
<b>14</b>	<b>Package outline</b> . . . . .	<b>14</b>
<b>15</b>	<b>Soldering of SMD packages</b> . . . . .	<b>15</b>
15.1	Introduction to soldering . . . . .	15
15.2	Wave and reflow soldering . . . . .	15
15.3	Wave soldering . . . . .	15
15.4	Reflow soldering . . . . .	16
<b>16</b>	<b>Abbreviations</b> . . . . .	<b>17</b>
<b>17</b>	<b>Revision history</b> . . . . .	<b>18</b>
<b>18</b>	<b>Legal information</b> . . . . .	<b>19</b>
18.1	Data sheet status . . . . .	19
18.2	Definitions . . . . .	19
18.3	Disclaimers . . . . .	19
18.4	Trademarks . . . . .	20
<b>19</b>	<b>Contact information</b> . . . . .	<b>20</b>
<b>20</b>	<b>Contents</b> . . . . .	<b>21</b>

Please be aware that important notices concerning this document and the product(s) described herein, have been included in section 'Legal information'.

© NXP B.V. 2012.

All rights reserved.

For more information, please visit: <http://www.nxp.com>

For sales office addresses, please send an email to: [salesaddresses@nxp.com](mailto:salesaddresses@nxp.com)

Date of release: 18 June 2012

Document identifier: CBTU4411