

Powerex, Inc., 200 Hillis Street, Youngwood, Pennsylvania 15697-1800 (412) 925-7272
 Powerex, Europe, S.A. 428 Avenue G. Durand, BP107, 72003 Le Mans, France (43) 41.14.14

Silicon Rectifier
400 Amperes Average
1600 Volts

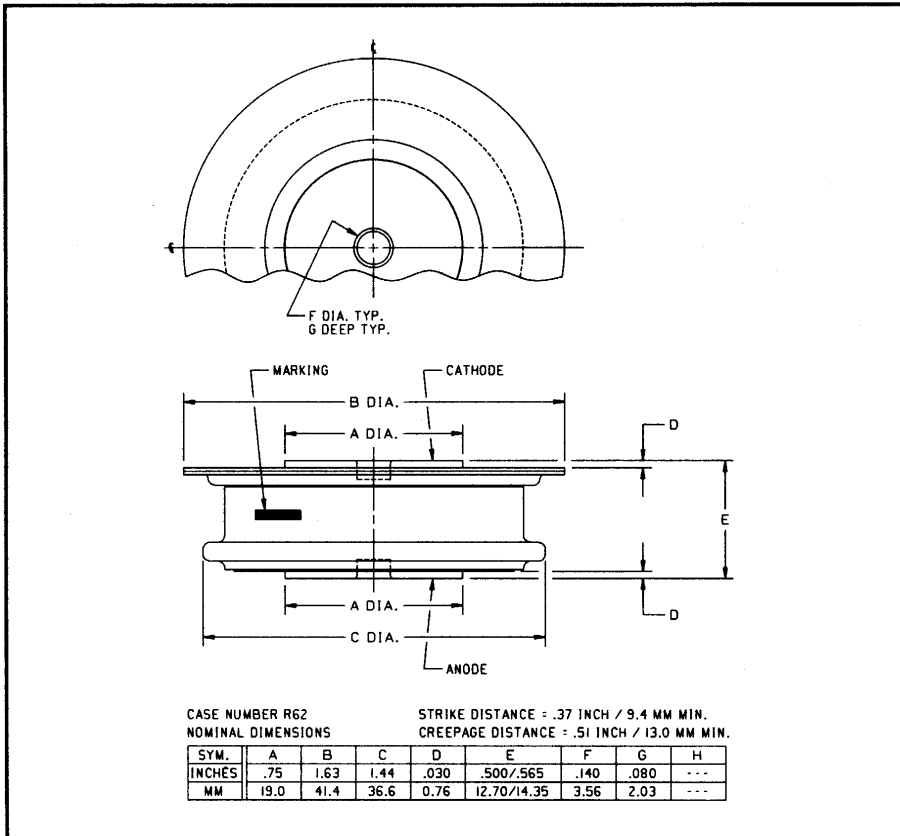

A390 (Outline Drawing)

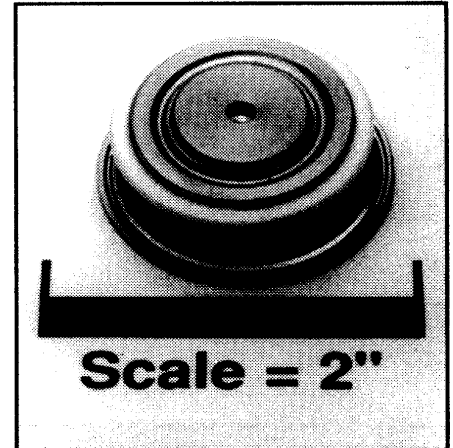

A390
 Silicon Rectifier
 400 Amperes Average, 1600 Volts

Ordering Information:

Select the complete five or six digit part number you desire from the table, i.e. A390PM is a 1600 Volt, 400 Ampere Silicon Rectifier.

Type	Voltage		Current $I_{T(av)}$
	V_{RRM}	Code	
A390	200	B	400
	400	D	
	600	M	
	800	N	
	1000	P	
	1200	PB	
	1400	PD	
1600	PM		

Features:

- Soft Reverse Recovery
- High Reverse Blocking Voltage Capability
- Pressure Contacts
- Package Reversibility
- Rugged Glazed Ceramic Hermetic Package

Applications:

- Auction Diode
- DC Power Supplies

A390
Silicon Rectifier
 400 Amperes Average, 1600 Volts

Absolute Maximum Ratings

Characteristics	Symbol	A390	Units
RMS Forward Current	$I_{F(rms)}$	628	Amperes
Average Forward Current	$I_{F(av)}$	400	Amperes
One Cycle Surge Current	I_{FSM}	7000	Amperes
I^2t (for Fusing), Times ≥ 1.0 milliseconds	I^2t	80000	A^2sec
Storage Temperature	T_{stg}	-40 to +200	$^{\circ}C$
Operating Temperature	T_j	-40 to +200	$^{\circ}C$
Mounting Force		$800 \pm 10\%$	lbs
		$3.56 \pm 10\%$	KN

Electrical and Thermal Characteristics

Characteristics	Symbol	Test Conditions	A390	Units
Current - Conducting State Maximums				
Forward Voltage Drop	V_{FM}	$T_C = 144^{\circ}C$, $I_{F(av)} = 400A, 1260A$ Peak	1.4	Volts
Voltage - Blocking State Maximums				
Repetitive Peak Reverse Voltage (Rated Limit)	V_{RRM}		1600	Volts
Non-rep. Trans. Peak Rev. Voltage (Rated Limit)	V_{RSM}	$V \leq 5.0msec$	1800	Volts
Reverse Leakage Current, mA peak	I_{RRM}	T_j at max., $V_{RRM} = \text{Rated}$	25	mA
Thermal				
Maximum Resistance, Junction to Case	$R_{\theta(j-c)}$		0.095	$^{\circ}C/Watt$

Powerex, Inc., 200 Hillis Street, Youngwood, Pennsylvania 15697-1800 (412) 925-7272
 Powerex, Europe, S.A. 428 Avenue G. Durand, BP107, 72003 Le Mans, France (43) 41.14.14

A390
Silicon Rectifier
 400 Amperes Average, 1600 Volts

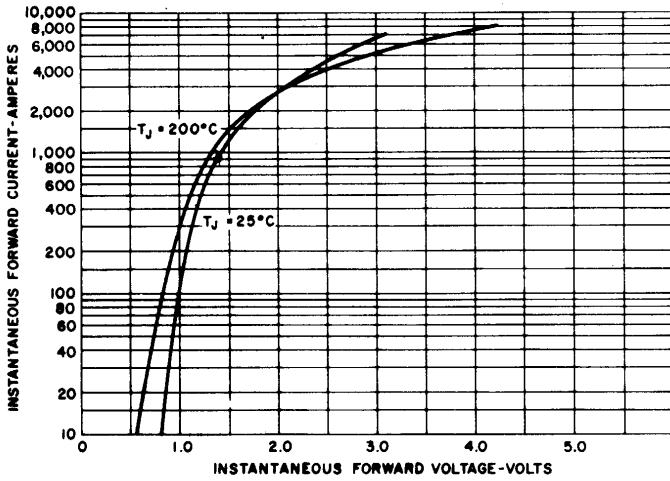

MAXIMUM FORWARD CHARACTERISTICS

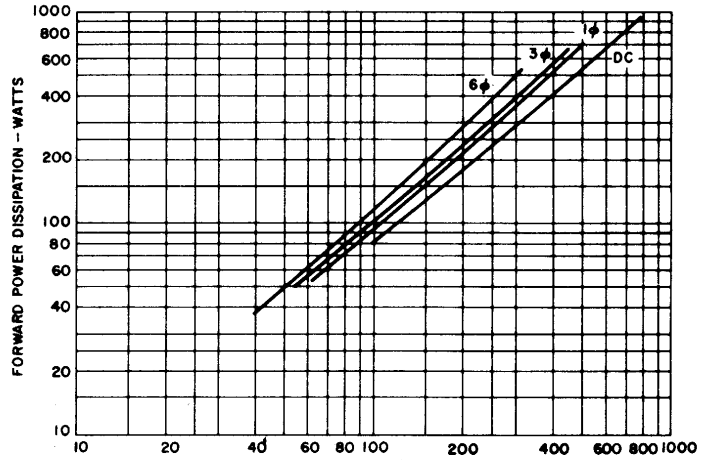

AVERAGE FORWARD POWER DISSIPATION VS. AVERAGE FORWARD CURRENT

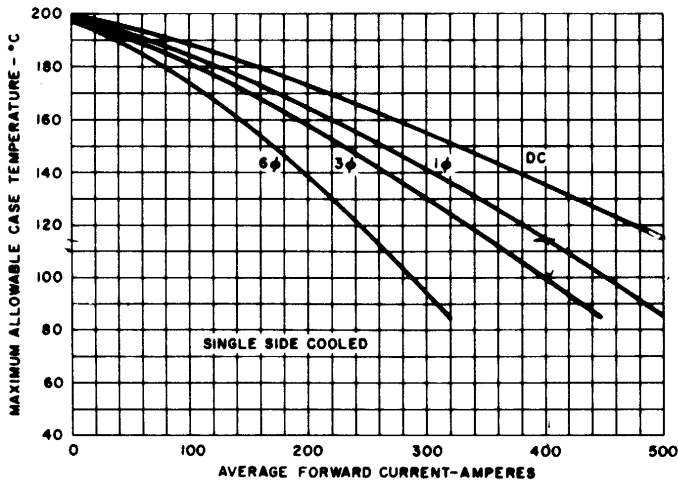

MAXIMUM CASE TEMPERATURE VS. AVERAGE FORWARD CURRENT FOR SINGLE-SIDE COOLING

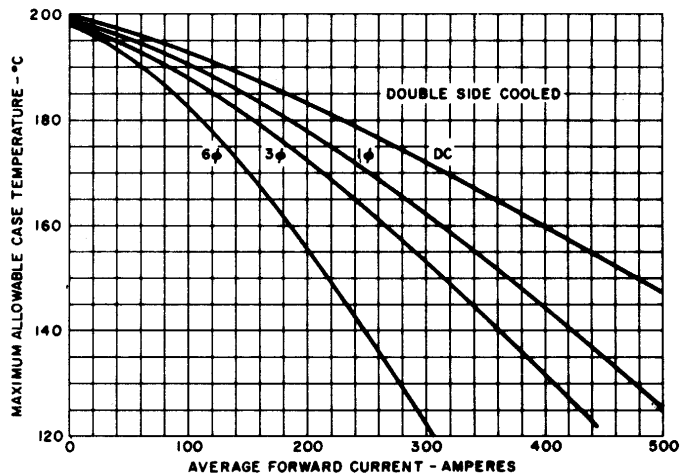

MAXIMUM CASE TEMPERATURE VS. AVERAGE FORWARD CURRENT FOR DOUBLE-SIDE COOLING

Powerex, Inc., 200 Hillis Street, Youngwood, Pennsylvania 15697-1800 (412) 925-7272
 Powerex, Europe, S.A. 428 Avenue G. Durand, BP107, 72003 Le Mans, France (43) 41.14.14

A390
Silicon Rectifier
 400 Amperes Average, 1600 Volts

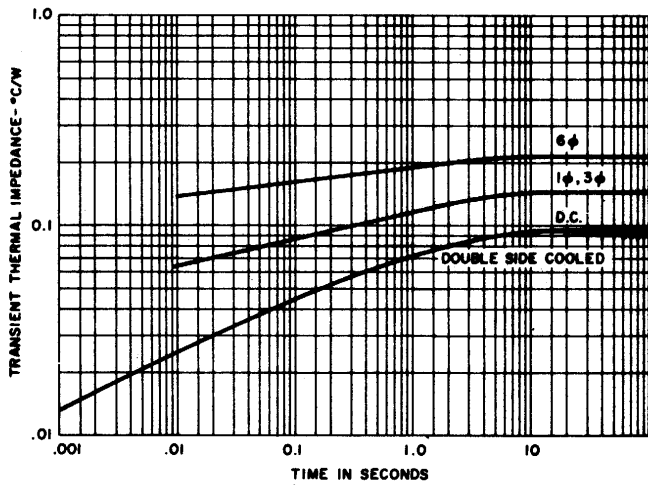

**TRANSIENT THERMAL IMPEDANCE –
 JUNCTION-TO-CASE**

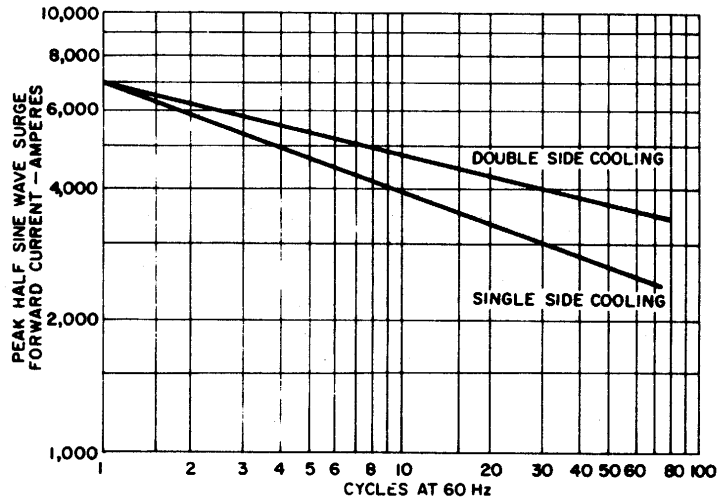

**MAXIMUM SURGE CURRENT FOLLOWING
 RATED LOAD CONDITIONS**

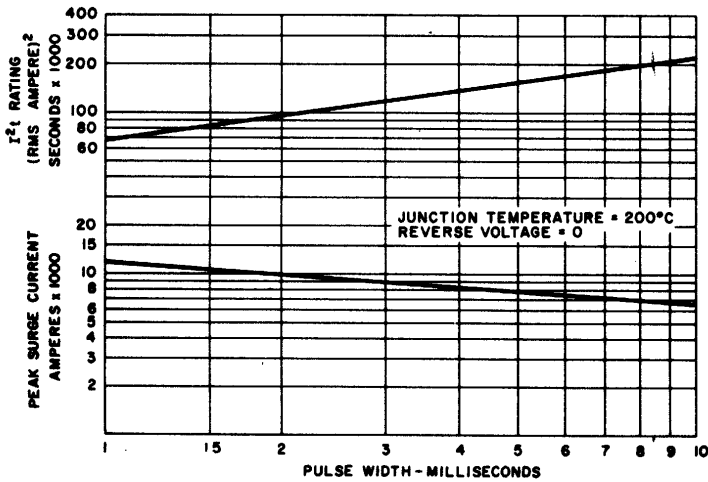

**SUB-CYCLE SURGE FORWARD CURRENT
 AND I^2t RATING VS. PULSE TIME
 FOLLOWING RATED LOAD CONDITIONS**