

ATLANTIC VERSION TERMINATOR INTERFACE ADAPTER	PART NUMBER	REVISION	DESCRIPTION	FEED TYPE	CONVERT TO	PART NUMBERS REQUIRED					
	2150345-1	A	FINE CRIMP HEIGHT ADJUST	MECHANICAL	PNEUMATIC FEED	2119950-1	2119792-2	-	2119641-1	-	2063440-1
					SERVO LATCH PLATE	2119951-1	1901697-1	8-2150345-5	-	-	2168400-7 (QUANTITY 2)
					SMART APPLICATOR	2161326-1	-	8-2150345-4	-	-	-
	2150345-2	A	FINE CRIMP HEIGHT ADJUST	PNEUMATIC	MECHANICAL FEED	2119949-1	2063961-1	5-18022-5	2119653-1	-	-
					SERVO LATCH PLATE	2119951-1	1901697-1	8-2150345-5	-	-	2168400-7 (QUANTITY 2)
					SMART APPLICATOR	2161326-1	-	8-2150345-4	-	-	-
	2150345-5	A	FINE CRIMP HEIGHT ADJUST	SERVO LATCH PLATE <sup>4</sup>	MECHANICAL FEED	2119949-1	2063961-1	5-18022-5	2119653-1	-	-
					PNEUMATIC FEED	2119950-1	2119792-2	-	2119641-1	-	2063440-1
	2150345-6	A	NON-CRIMP HEIGHT ADJUST	SERVO LATCH PLATE <sup>4</sup>	-	-	-	-	-	-	-
	2150345-7	A	FINE CRIMP HEIGHT ADJUST	NONE	-	-	-	-	-	-	-
	7-2150345-7	A	CRIMP TOOLING KIT	-	-	-	-	-	-	-	-

APPLICATOR DATA		
CRIMP	SIZE	TYPE
WIRE	1.57 mm [.062]	F
INSUL	3.94 mm [.155]	F
APPLICATOR INSTRUCTIONS 408-10390		

TERMINAL DATA: TE TERMINAL		TE CRIMP SPECIFICATION
TERMINAL NAME: RECEPTACLE, FASTON .110 SERIES		
WIRE STRIP LENGTH		INSULATION DIAMETER RANGE
5.21-5.97 mm [.205-.235 IN]		Ø3.05-3.56 mm [.120-.140 IN]
TERMINAL APPLICATION SPECIFICATION	114-2036	
TERMINALS APPLIED		
TE TERMINAL	TE TERMINAL	TE TERMINAL
60729-1	61158-1	

WIRE SIZE	CRIMP HEIGHT mm [INCH]	CRIMP HEIGHT REFERENCE SETTING
18 AWG	1.25 +/- 0.05 [.049 +/- .002]	5.3
20 AWG	1.09 +/- 0.05 [.043 +/- .002]	7.0
22 AWG	1.02 +/- 0.05 [.040 +/- .002]	7.8

- <sup>1</sup> RECOMMENDED SPARE PARTS
- <sup>2</sup> GREASE BEARING SURFACES LIGHTLY
- 3. LUBRICATE DAILY PER THE APPLICATOR INSTRUCTION SHEET SUPPLIED WITH THE APPLICATOR.
- <sup>4</sup> APPLICATOR SPECIFIC DATA TO BE ENTERED INTO BLANK MEMORY CHIP AT ASSEMBLY. SEE BELOW FOR PART NUMBER:  
 MECHANICAL FEED WITH "SMART APPLICATOR" CONVERSION: 8-2150345-4  
 PNEUMATIC FEED WITH "SMART APPLICATOR" CONVERSION: 8-2150345-4  
 SERVO FEED WITH "FINE CRIMP HEIGHT ADJUST": 8-2150345-5  
 SERVO FEED WITH "NON-CRIMP HEIGHT ADJUST": 8-2150345-6
- 5. ADJUSTMENT OF THE STRIPPER MAY BE REQUIRED WHEN MOVING THE APPLICATOR BETWEEN BENCH AND LEADMAKER APPLICATIONS.
- <sup>6</sup> APPLY PART NUMBER 1-23419-5 LOCTITE TO THREADS OF ITEMS 180, 62 & 242. FOR -6 ONLY APPLY PART NUMBER 1-23419-5 LOCTITE TO THREADS OF ITEMS 37, 180 & 242.
- <sup>7</sup> GREASE THREADS, GROOVE AND O-RING ON ITEMS 35 & 252.
- <sup>8</sup> MAGNET, ITEM 166 MUST BE ORIENTED CORRECTLY IN ORDER TO PROPERLY ACTUATE THE COUNTER.
- <sup>9</sup> CRIMP HEIGHT REFERENCE SETTING WAS THE SETTING USED WHEN THE APPLICATOR WAS QUALIFIED AT THE FACTORY. ADJUSTMENT MAY BE NECESSARY WHEN RUNNING APPLICATOR IN THE FIELD.
- <sup>10</sup> SPARE FEED CAM STORAGE LOCATION REFER TO INSTRUCTION SHEET FOR ADDITIONAL INFORMATION.
- <sup>11</sup> THE RECOMMENDED SET-UP FOR END FEED APPLICATORS IS POST-FEED WITH ITEM 2119653-1. THE APPLICATOR CAN BE CONFIGURED FOR PRE-FEED WITH ITEM 2119652-1 BUT MAY ENCOUNTER PROBLEMS WITH SOME APPLICATIONS. FEED ISSUES OR TERMINAL JAMMING MAY OCCUR IN THE PRE-FEED CONFIGURATION.
- <sup>12</sup> WHEN ASSEMBLING -6 NON-CRIMP HEIGHT ADJUST APPLICATOR USE SHIM PACK 2119957-2 TO ALIGN APPLICATOR'S MAXIMUM WIRE CRIMP HEIGHT AT NORMAL TERMINATOR SHUT HEIGHT

**\*WARNING**  
 ON INSTALLATION, SET WIRE DISC, ITEM 40 TO LARGEST WIRE SIZE SETTING. USE OF SETTINGS BELOW MINIMUM REQUIRED CRIMP HEIGHT SETTING WILL CAUSE DAMAGE TO CRIMP TOOLING.

-	-	1	-	-	-	2119957-2	APPLICATOR SHIM PACK	260
-	1	-	1	1	1	8-21084-0	O-RING, .676 ID, .070 DIA. MAT.	252
-	-	-	-	1	-	2119640-1	PUSH ROD, AIR FEED	250
-	-	-	-	1	-	2079988-1	BUSHING, LCH5-12, MISUMI	249
-	-	-	-	1	-	2119641-1	FEED CAM, AIR FEED	248
-	1	-	1	1	1	2119798-1	DETENT PIN	247
-	1	-	1	1	1	1-22279-3	SPRING, COMPRESSION	246
-77	-7	-6	-5	-2	-1	PART NO	DESCRIPTION	ITEM NO

**ATLANTIC VERSION**  
 Shown on sheets 1 of 4 & 2 of 4  
 (Pacific version shown on sheets 3 of 4 & 4 of 4)

SET UP GAUGE	LOC	DIST	REVISIONS					
2119599-2	A	66	P	LTM	DESCRIPTION	DATE	OWN	APVD
			A		RELEASED	27AUG2013	CC	TE

-	-	1	-	-	-	2119759-1	RAM, AMP STYLE, END FEED, NON-ADJUST	245
-	1	1	1	1	1	2119082-9	CAM, SNAIL, INSULATION ADJUSTMENT	244
-	1	1	1	1	1	2079764-1	WASHER, WAVE SPRING, CREST-TO-CREST	243
-	1	1	1	1	1	2119083-1	RETAINER, INSULATION DIAL	242
-	-	2	2	-	-	2168400-7	SHCS, LOW HEAD, RoHS, M5 X 10	240
-	-	-	-	-	1	2119580-1	MECHANICAL FEED ASSEMBLY	239
-	-	-	-	1	-	2063440-1	AIR FEED MODULE	238
-	-	1	1	-	-	2119740-2	TAG, IDENTIFICATION	213
-	-	REF	REF	-	-	1901697-1	FEED FINGER ASSEMBLY, EF	183
-	1	1	1	1	1	1752354-7	STANDOFF, HOLD-DOWN	180
-	1	1	1	1	1	6-993111-6	PIN, SLOTTED SPRING 3.0 X 14.0	177
-	1	1	1	1	1	8-22280-7	SPRING, COMPRESSION	176
-	1	1	1	1	1	1752353-2	GUIDE PIN, HOLDDOWN	175
-	1	1	1	1	1	1901680-2	GUIDE PIN, HOLDDOWN	174
-	-	-	-	2	-	21045-3	RING, RETAIN, EXTERN, 3/16 CRESCENT	172
-	-	-	-	1	1	994969-1	MAGNET, RARE EARTH HIGH ENERGY	166
-	REF	REF	REF	REF	REF	994970-2	COUNTER, MAGNETIC	164
-	-	-	-	1	-	240638-1	SPRING, FEED FINGER	163
-	-	-	-	1	-	3-23627-7	PIN, RETAIN, GRVD, 3/16 X .854	137
-	-	REF	REF	-	-	SEE NOTE 4	MEMORY CHIP, PROGRAMMED	135
-	-	1	1	-	-	1633743-1	SERVO FEED LATCH ASM	133
-	1	1	1	1	1	455888-4	SPACER, CRIMPER	82
-	1	1	1	1	1	2119956-2	DOCUMENTATION PACKAGE	71
-	2	2	2	2	2	2-18032-2	SCR, SET, FLT POINT M3 X 10.0	70
-	1	-	-	1	1	2119740-1	TAG, IDENTIFICATION	67
-	2	2	2	2	2	2168078-1	SCREW, DRIVE, RH, RoHS, 2 x .188	66
-	1	1	1	1	1	1901681-5	HOLDDOWN, TERMINAL	65
-	2	2	2	2	2	2168400-5	SHCS, LOW HEAD, RoHS, M4 X 20	64
-	1	-	1	1	1	2119793-1	LIMITER, ADJUSTMENT BOLT	63
-	3	-	3	3	3	992763-5	SCR, SET, SOC, CONE POINT, M3 x 4.0	62
-	1	1	1	1	1	2079383-4	SCR, BHSC, RoHS (M4 X 8)	60
-	-	-	-	-	1	5-18022-5	SCR, HEX HD CAP, M4 X 6.0	59
-	-	-	-	-	1	2063961-1	FEED FINGER	58
-	3	3	3	3	3	2168400-4	SHCS, LOW HEAD, RoHS, M4 X 8	57
-	2	2	2	2	2	2168083-2	SCR, SKT HD CAP, RoHS, M4 X 8.0	56
-	2	2	2	2	2	5018030-2	NUT, HEX, REG, RoHS, M4	55
-	2	2	2	2	2	5018030-1	NUT, HEX, REG, RoHS, M3	54
-	2	2	2	2	2	986965-8	NUT, LOCK, HEX, TORQUE (M4)	53
-	1	1	1	1	1	1-5018030-0	NUT, HEX, REG, RoHS, M3.5	52
-	-	-	-	1	-	2119792-2	PAWL, EF, AIR	51
-	-	-	-	1	2	18023-9	SCR, SKT HD CAP M4 X 6.0	49
-	-	-	-	-	1	2119652-1	FEED CAM, PRE FEED	48
-	-	-	-	-	1	2119653-1	FEED CAM, POST FEED	47
-	1	1	1	1	1	2119655-5	APPLICATOR BASIC ASSEMBLY, EF	46
-	1	-	1	1	1	2119369-1	RAM, AMP STYLE, END FEED	44
-	1	1	1	1	1	2079383-7	SCR, BHSC, RoHS (M8 X 25)	41
-	1	-	1	1	1	2119645-1	DISC, NUMBERED FA WIRE ADJUSTMENT	40
-	1	-	1	1	1	2119957-1	APPLICATOR SHIM PACK	39
-	1	1	1	1	1	2119644-1	RAM WASHER, PRECISION	38
-	1	1	1	1	1	2119085-1	FA HEAD, ATLANTIC STYLE	37
-	1	-	1	1	1	2119092-1	BOLT, ADJUSTMENT	35
-	7	7	7	7	7	1-18028-2	WASHER, FLAT, REG M4	33
-	2	2	2	2	2	2168083-8	SCR, SKT HD CAP, RoHS, M4 X 16	31
-	2	2	2	2	2	1-2168083-0	SCR, SKT HD CAP, RoHS, M4 X 10	29
-	1	1	1	1	1	240639-1	STRIPPER (MACHINING)	27
-	2	2	2	2	2	1320906-1	STUD, THREADED	25
-	1	1	1	1	1	1-1752371-2	PLATE, STRIP GUIDE	24
-	1	1	1	1	1	240825-3	PLATE, STRIP HOLD DOWN	23
-	2	2	2	2	2	2-22281-3	SPRING, COMPRESSION	22
-	1	1	1	1	1	1752373-4	DRAG	20
-	2	2	2	2	2	1901259-3	GUIDE, LOWER STRIP	18
-	4	4	4	4	4	1-2079383-1	SCR, BHSC, RoHS (M6 X 12)	17
-	1	1	1	1	1	240644-5	PLATE, REAR SHEAR	11
-	-	-	-	-	-	-	-	10
-	1	1	1	1	1	1-690482-8	PLATE, FRONT SHEAR	9
-	1	1	1	1	1	2-1803001-3	ANVIL, COMBINATION, END FEED	8
-	1	1	1	1	1	690474-5	BLADE, SLUG	7
-	-	-	-	-	-	-	-	6
-	1	1	1	1	1	4-240641-6	SPACER	5
-	1	1	1	1	1	238009-1	BLOCK, FL CRIMPER SPACER	4
-	1	1	1	1	1	3-2119582-6	CRIMPER, INSULATION F PREMIUM	3
-	1	1	1	1	1	455888-8	SPACER, CRIMPER	2
-	1	1	1	1	1	1-456403-5	CRIMPER, WIRE PREMIUM	1
-77	-7	-6	-5	-2	-1	PART NO	DESCRIPTION	ITEM NO

DIMENSIONS:		TOLERANCES UNLESS OTHERWISE SPECIFIED:		DATE		NAME	
mm	0 PLC ±.5	1 PLC ±.3	2 PLC ±.13	3 PLC ±.013	4 PLC ±.0001	ANGLES ±.0001	FINISH
MATERIAL				FINISH			
WEIGHT				SCALE			
Customer Accessible Production Drawing				SCALE 1:1 SHEET 1 OF 4 REV A			

LOC	DIST	REV	DATE	BY	APPV
A	66				
REVISIONS			DESCRIPTION	DATE	BY
-			SEE SHEET 1	-	-

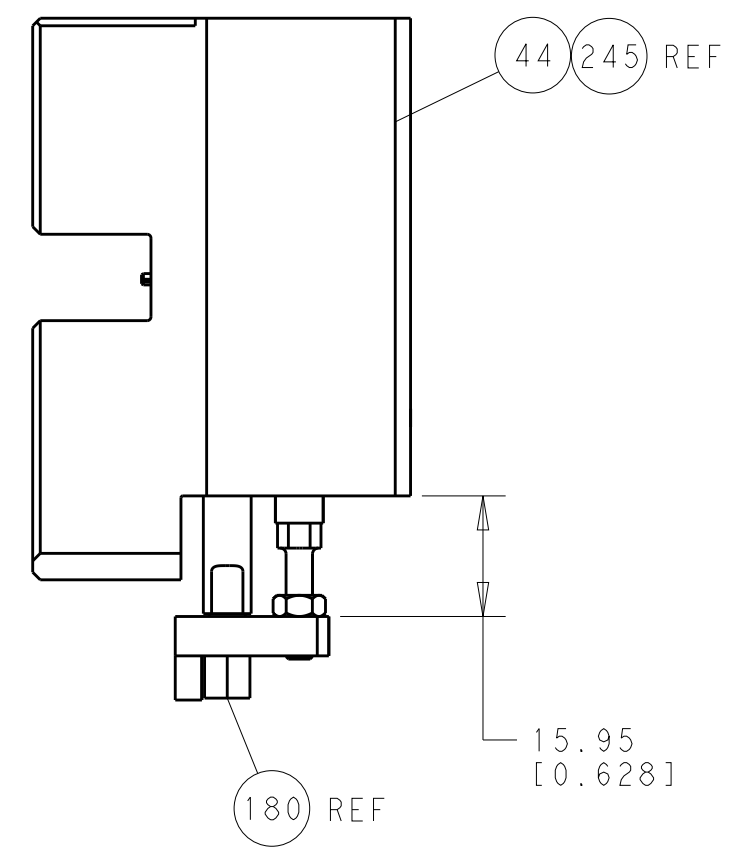

HOLDDOWN SET-UP

FEED TYPE  
MECHANICAL

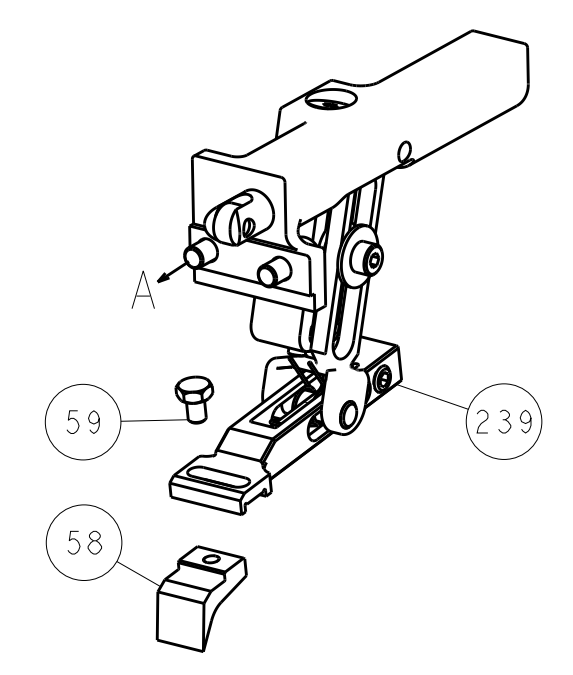

PNEUMATIC

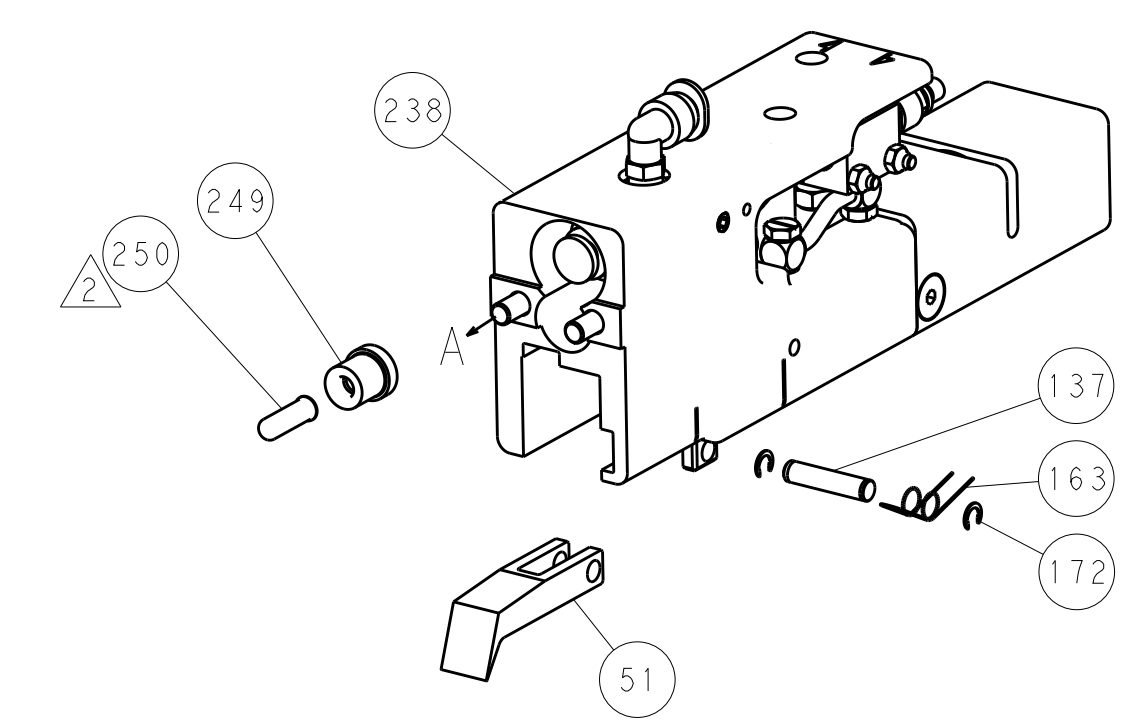

SERVO  
LATCH PLATE

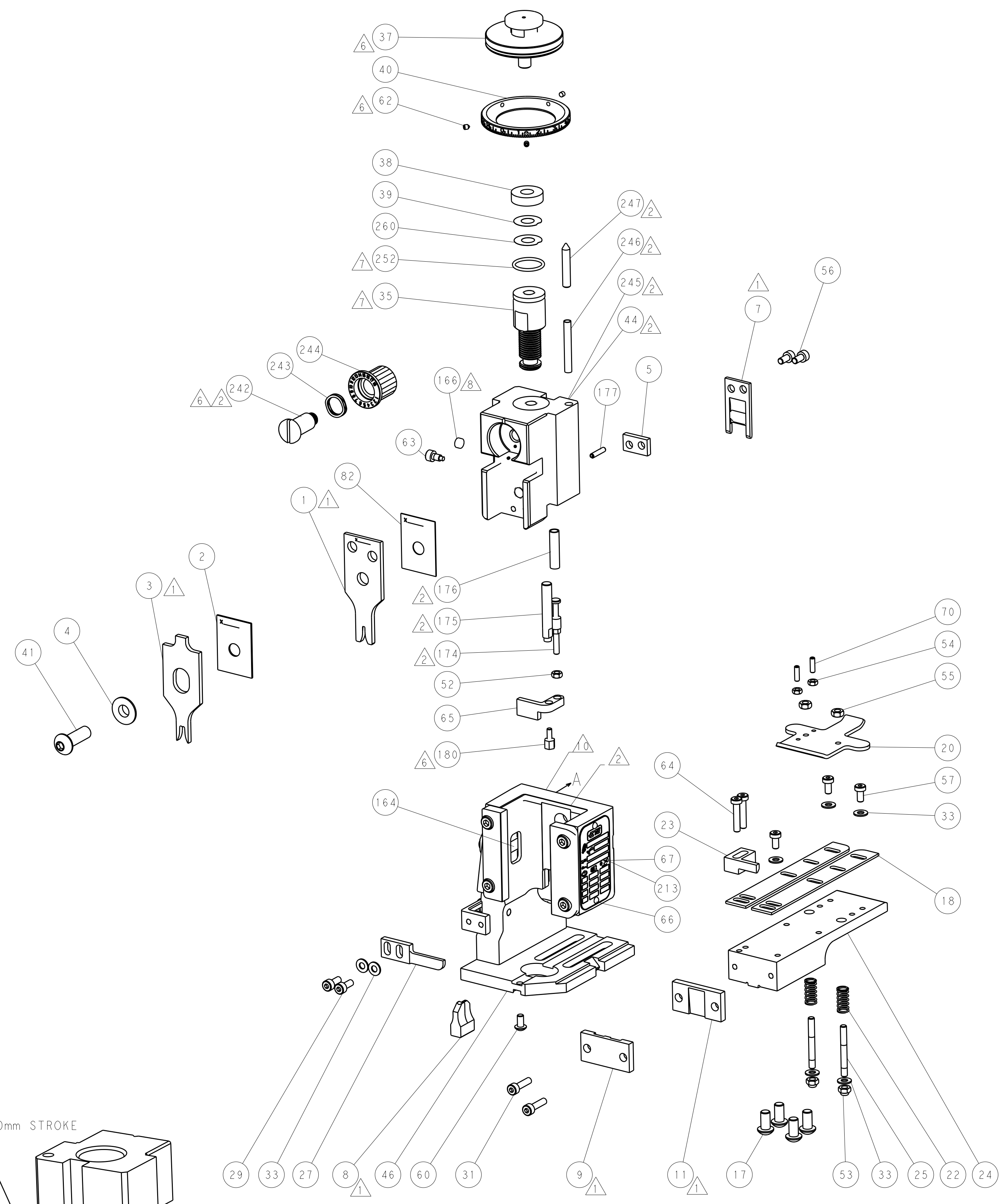
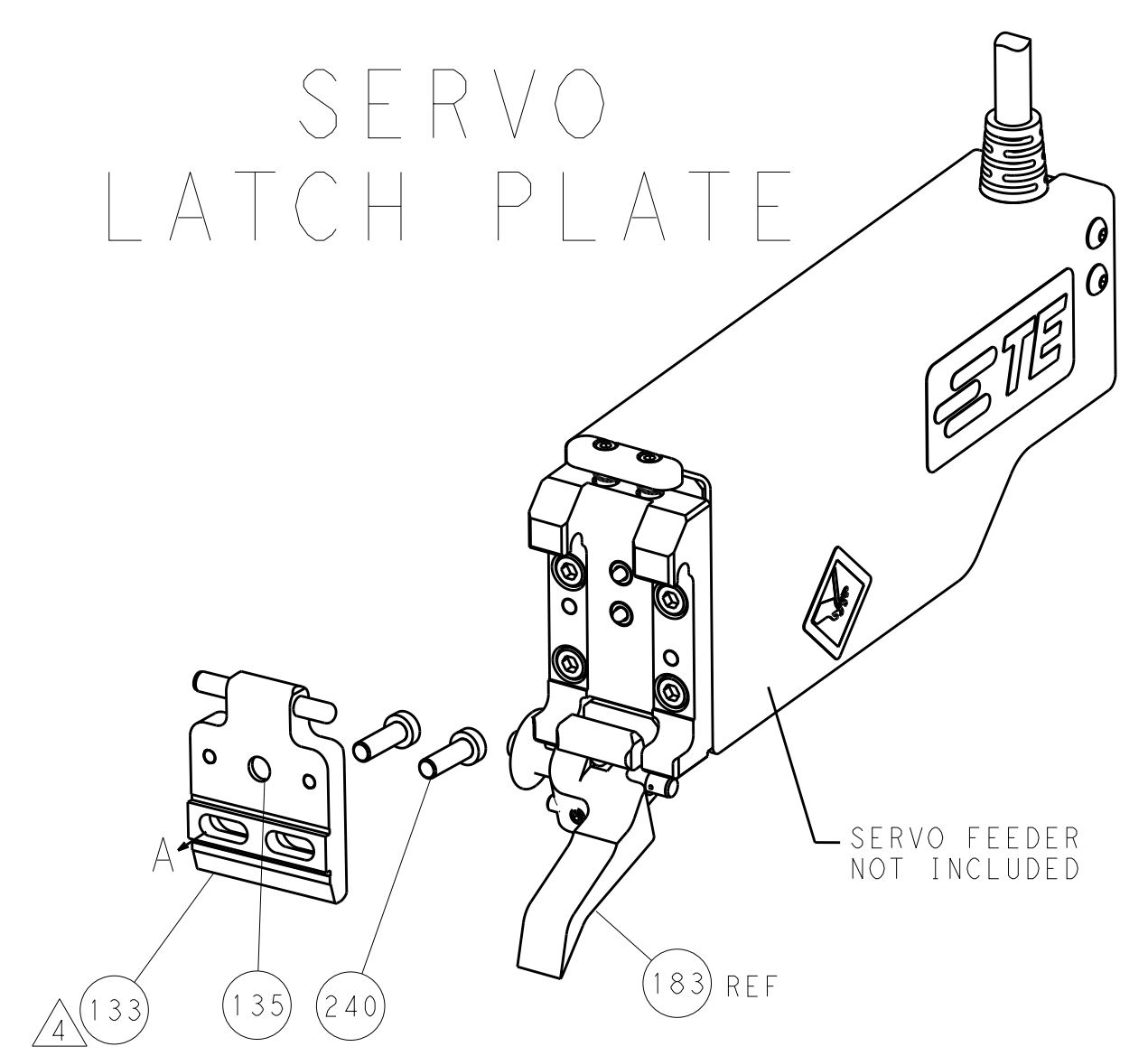

CAM POSITIONS



ATLANTIC VERSION  
 Shown on sheets 1 of 4 & 2 of 4  
 (Pacific version shown on sheets 3 of 4 & 4 of 4)

DIMENSIONS:		TOLERANCES UNLESS OTHERWISE SPECIFIED:		DWG: C. CHEN 20JUN2013		TE Connectivity	
mm		0 PLC ±0.5		CHK: U. GUO 20JUN2013		Harrisburg, PA 17105-3608	
Ø		1 PLC ±0.13		APPV: J. CRUZ 20JUN2013		NAME: Ocean End Feed Applicator	
H		2 PLC ±0.013		PRODUCT SPEC		SIZE: CAGE CODE DRAWING NO	
ANGLES		3 PLC ±0.001		APPLICATION SPEC		RESTRICTED TO	
FINISH		4 PLC ±0.001		WEIGHT		A1 00779 ©=2150345	
MATERIAL		5 PLC ±0.001		Customer Accessible Production Drawing		SCALE: 1:1 SHEET 2 OF 4 REV A	

PACIFIC VERSION TERMINATOR INTERFACE ADAPTER	PART NUMBER	REVISION	DESCRIPTION	FEED TYPE	APPLICATOR STYLE CONVERSION CHART						
					CONVERT TO	PART NUMBERS REQUIRED					
	2-2150345-1	A	FINE CRIMP HEIGHT ADJUST	MECHANICAL	PNEUMATIC FEED	2119950-1	2119792-2	-	2119641-2	-	2063440-1
					SERVO LATCH PLATE	2119951-1	1901697-1	8-2150345-5	-	-	2168400-7 (QUANTITY 2)
					SMART APPLICATOR	2161326-1	-	8-2150345-4	-	-	-
	2-2150345-2	A	FINE CRIMP HEIGHT ADJUST	PNEUMATIC	MECHANICAL FEED	2119949-1	2063961-1	5-18022-5	2119653-2	-	-
					SERVO LATCH PLATE	2119951-1	1901697-1	8-2150345-5	-	-	2168400-7 (QUANTITY 2)
					SMART APPLICATOR	2161326-1	-	8-2150345-4	-	-	-
	2-2150345-5	A	FINE CRIMP HEIGHT ADJUST	SERVO LATCH PLATE	MECHANICAL FEED	2119949-1	2063961-1	5-18022-5	2119653-2	-	-
					PNEUMATIC FEED	2119950-1	2119792-2	-	2119641-2	-	2063440-1
	2-2150345-7	A	FINE CRIMP HEIGHT ADJUST	NONE	-	-	-	-	-	-	-
	7-2150345-7	A	CRIMP TOOLING KIT	-	-	-	-	-	-	-	-

APPLICATOR DATA		
CRIMP SIZE	TYPE	
WIRE 1.57 mm (.062)	F	
INSUL 3.94 mm (.155)	F	
APPLICATOR INSTRUCTIONS 408-10390		

TERMINAL DATA: TE TERMINAL		TE CRIMP SPECIFICATION
TERMINAL NAME: RECEPTACLE, FASTON .110 SERIES		
WIRE STRIP LENGTH		INSULATION DIAMETER RANGE
5.21-5.97 mm (.205-.235 IN)		3.05-3.56 mm (.120-.140 IN)
TERMINAL APPLICATION SPECIFICATION	114-2036	
TERMINALS APPLIED		
TE TERMINAL	TE TERMINAL	TE TERMINAL
60729-1	61158-1	

WIRE SIZE	CRIMP HEIGHT mm [INCH]	CRIMP HEIGHT REFERENCE SETTING
18 AWG	1.25 +/- 0.05 [0.049 +/- .002]	5.3
20 AWG	1.09 +/- 0.05 [0.043 +/- .002]	7.0
22 AWG	1.02 +/- 0.05 [0.040 +/- .002]	7.8

- RECOMMENDED SPARE PARTS
- GREASE BEARING SURFACES LIGHTLY
- LUBRICATE DAILY PER THE APPLICATOR INSTRUCTION SHEET SUPPLIED WITH THE APPLICATOR.
- APPLICATOR SPECIFIC DATA TO BE ENTERED INTO BLANK MEMORY CHIP AT ASSEMBLY. SEE BELOW FOR PART NUMBER:  
 MECHANICAL FEED WITH "SMART APPLICATOR" CONVERSION: 8-2150345-4  
 PNEUMATIC FEED WITH "SMART APPLICATOR" CONVERSION: 8-2150345-4  
 SERVO FEED WITH "FINE CRIMP HEIGHT ADJUST": 8-2150345-5
- ADJUSTMENT OF THE STRIPPER MAY BE REQUIRED WHEN MOVING THE APPLICATOR BETWEEN BENCH AND LEADMAKER APPLICATIONS.
- APPLY PART NUMBER 1-23419-5 LOCTITE TO THREADS OF ITEMS 62, 180 & 242.
- GREASE THREADS, GROOVE AND O-RING ON ITEMS 139 & 153.
- MAGNET, ITEM 166 MUST BE ORIENTED CORRECTLY IN ORDER TO PROPERLY ACTUATE THE COUNTER.
- CRIMP HEIGHT REFERENCE SETTING WAS THE SETTING USED WHEN THE APPLICATOR WAS QUALIFIED AT THE FACTORY. ADJUSTMENT MAY BE NECESSARY WHEN RUNNING APPLICATOR IN THE FIELD.
- SPARE FEED CAM STORAGE LOCATION REFER TO INSTRUCTION SHEET FOR ADDITIONAL INFORMATION.
- THE RECOMMENDED SET-UP FOR END FEED APPLICATORS IS POST-FEED WITH ITEM 2119653-1. THE APPLICATOR CAN BE CONFIGURED FOR PRE-FEED WITH ITEM 2119652-1 BUT MAY ENCOUNTER PROBLEMS WITH SOME APPLICATIONS. FEED ISSUES OR TERMINAL JAMMING MAY OCCUR IN THE PRE-FEED CONFIGURATION.

**\*WARNING**  
 ON INSTALLATION, SET WIRE DISC, ITEM 40 TO LARGEST WIRE SIZE SETTING. USE OF SETTINGS BELOW MINIMUM REQUIRED CRIMP HEIGHT SETTING WILL CAUSE DAMAGE TO CRIMP TOOLING.

	ITEM NO	DESCRIPTION	ITEM NO
- 1 1 1 1 1	2119782-1	FINE ADJUST HEAD ASM, PACIFIC STYLE	251
- - - 1 -	2119640-1	PUSH ROD, AIR FEED	250
- - - 1 -	2079988-1	BUSHING, LCH5-12, MISUMI	249
- 1 1 1 1 1	1-22279-3	SPRING, COMPRESSION	246
- 1 1 1 1 1	2119082-9	CAM, SNAIL, INSULATION ADJUSTMENT	244
-77-27-25-22-21	PART NO	DESCRIPTION	ITEM NO

**PACIFIC VERSION**  
 Shown on sheets 3 of 4 & 4 of 4  
 (Atlantic version shown on sheets 1 of 4 & 2 of 4)

SET UP GAUGE	LOC	DIST	REVISIONS			
2119599-2	A	66	REV	DATE	BY	APPV
			-	SEE SHEET 1	-	-

- 1 1 1 1 1	2079764-1	WASHER, WAVE SPRING, CREST-TO-CREST	243
- 1 1 1 1 1	2119083-1	RETAINER, INSULATION DIAL	242
- - 2 - -	2168400-7	SHCS, LOW HEAD, RoHS, M5 X 10	240
- - - - 1	2119580-1	MECHANICAL FEED ASSEMBLY	239
- - - 1 -	2063440-1	AIR FEED MODULE	238
- - 1 - -	2119740-2	TAG, IDENTIFICATION	213
- 4 4 4 4	2079383-9	SCR, BHSC, RoHS (M6 X 20)	186
- - REF - -	1901697-1	FEED FINGER ASSEMBLY, EF	183
- 1 1 1 1 1	1752354-7	STANDOFF, HOLD-DOWN	180
- 1 1 1 1 1	6-993111-6	PIN, SLOTTED SPRING 3.0 X 14.0	177
- 1 1 1 1 1	8-22280-7	SPRING, COMPRESSION	176
- 1 1 1 1 1	1752353-2	GUIDE PIN, HOLDDOWN	175
- 1 1 1 1 1	1901680-2	GUIDE PIN, HOLDDOWN	174
- - - 2 -	21045-3	RING, RETAIN, EXTERN, 3/16 CRESCENT	172
- 1 1 1 1 1	994969-1	MAGNET, RARE EARTH HIGH ENERGY	166
- REF REF REF REF	994970-2	COUNTER, MAGNETIC	164
- - - 1 -	240638-1	SPRING, FEED FINGER	163
- 1 1 1 1 1	8-21084-1	O-RING, .801 ID, .070 DIA. MAT.	153
- - - 1 -	2119641-2	FEED CAM, AIR FEED	152
- 1 1 1 1 1	2119798-2	DETENT PIN	145
- 1 1 1 1 1	2079383-8	SCR, BHSC, RoHS (M4 X 16)	144
- - - - 1	2119653-2	FEED CAM, POST FEED	142
- 1 1 1 1 1	2119655-6	APPLICATOR BASIC ASSEMBLY, EF	141
- 1 1 1 1 1	2119651-1	RAM, ASIAN STYLE, END FEED	140
- 1 1 1 1 1	2119092-2	BOLT, ADJUSTMENT	139
- - - 1 -	3-23627-7	PIN, RETAIN, GRVD, 3/16 X .854	137
- - REF - -	SEE NOTE 4	MEMORY CHIP, PROGRAMMED	135
- - 1 - -	1633743-1	SERVO FEED LATCH ASM	133
- 1 1 1 1 1	455888-4	SPACER, CRIMPER	82
- 1 1 1 1 1	2119956-2	DOCUMENTATION PACKAGE	71
- 2 2 2 2	2-18032-2	SCR, SET, FLT POINT M3 X 10.0	70
- 1 - 1 1 1	2119740-1	TAG, IDENTIFICATION	67
- 2 2 2 2	2168078-1	SCREW, DRIVE, RH, RoHS, 2 x .188	66
- 1 1 1 1 1	1901681-5	HOLDDOWN, TERMINAL	65
- 2 2 2 2	2168400-5	SHCS, LOW HEAD, RoHS, M4 X 20	64
- 1 1 1 1 1	2119793-1	LIMITER, ADJUSTMENT BOLT	63
- 3 3 3 3	992763-5	SCR, SET, SOC, CONE POINT, M3 X 4.0	62
- - - - 1	5-18022-5	SCR, HEX HD CAP, M4 X 6.0	59
- - - - 1	2063961-1	FEED FINGER	58
- 3 3 3 3	2168400-4	SHCS, LOW HEAD, RoHS, M4 X 8	57
- 2 2 2 2	2168083-2	SCR, SKT HD CAP, RoHS, M4 X 8.0	56
- 2 2 2 2	5018030-2	NUT, HEX, REG, RoHS, M4	55
- 2 2 2 2	5018030-1	NUT, HEX, REG, RoHS, M3	54
- 2 2 2 2	986965-8	NUT, LOCK, HEX, TORQUE (M4)	53
- 1 1 1 1 1	1-5018030-0	NUT, HEX, REG, RoHS, M3.5	52
- - - 1 -	2119792-2	PAWL, EF, AIR	51
- - - 1 2	18023-9	SCR, SKT HD CAP M4 X 6.0	49
- - - - 1	2119652-1	FEED CAM, PRE FEED	48
- 1 1 1 1 1	2079383-7	SCR, BHSC, RoHS (M8 X 25)	41
- 1 1 1 1 1	2119645-1	DISC, NUMBERED FA WIRE ADJUSTMENT	40
- 1 1 1 1 1	2119957-1	APPLICATOR SHIM PACK	39
- 1 1 1 1 1	2119644-1	RAM WASHER, PRECISION	38
- 7 7 7 7	1-18028-2	WASHER, FLAT, REG M4	33
- 2 2 2 2	2168083-8	SCR, SKT HD CAP, RoHS, M4 X 16	31
- 2 2 2 2	1-2168083-0	SCR, SKT HD CAP, RoHS, M4 X 10	29
- 1 1 1 1 1	240639-1	STRIPPER (MACHINING)	27
- 2 2 2 2	1320906-1	STUD, THREADED	25
- 1 1 1 1 1	1-1752371-2	PLATE, STRIP GUIDE	24
- 1 1 1 1 1	240825-3	PLATE, STRIP HOLD DOWN	23
- 2 2 2 2	2-22281-3	SPRING, COMPRESSION	22
- 1 1 1 1 1	1752373-4	DRAG	20
- 2 2 2 2	1901259-3	GUIDE, LOWER STRIP	18
- 1 1 1 1 1	240644-5	PLATE, REAR SHEAR	11
- - - - -	-	-	10
- 1 1 1 1 1	1-690482-8	PLATE, FRONT SHEAR	9
1 1 1 1 1	2-1803001-3	ANVIL, COMBINATION, END FEED	8
- 1 1 1 1 1	690474-5	BLADE, SLUG	7
- - - - -	-	-	6
- 1 1 1 1 1	4-240641-6	SPACER	5
- 1 1 1 1 1	238009-1	BLOCK, FL CRIMPER SPACER	4
1 1 1 1 1	3-2119582-6	CRIMPER, INSULATION F PREMIUM	3
- 1 1 1 1 1	455888-8	SPACER, CRIMPER	2
1 1 1 1 1	1-456403-5	CRIMPER, WIRE PREMIUM	1
-77-27-25-22-21	PART NO	DESCRIPTION	ITEM NO

DIMENSIONS:		TOLERANCES UNLESS OTHERWISE SPECIFIED:		DATE		NAME	
mm	0 PLC ±.5	1 PLC ±.5	2 PLC ±.5	3 PLC ±.5	20JUN2013	20JUN2013	TE Connectivity
	4 PLC ±.013	5 PLC ±.013	6 PLC ±.013	7 PLC ±.013			Harrisburg, PA 17105-3608
	ANGLES ±.0001						
MATERIAL:	FINISH:	WEIGHT:	SCALE:	Customer Accessible Production Drawing	1:1	SHEET 3 OF 4	REV A

LOC		DIST		REVISIONS			
A	66	P	LTM	DESCRIPTION	DATE	OWN	APVD
				SEE SHEET 1			

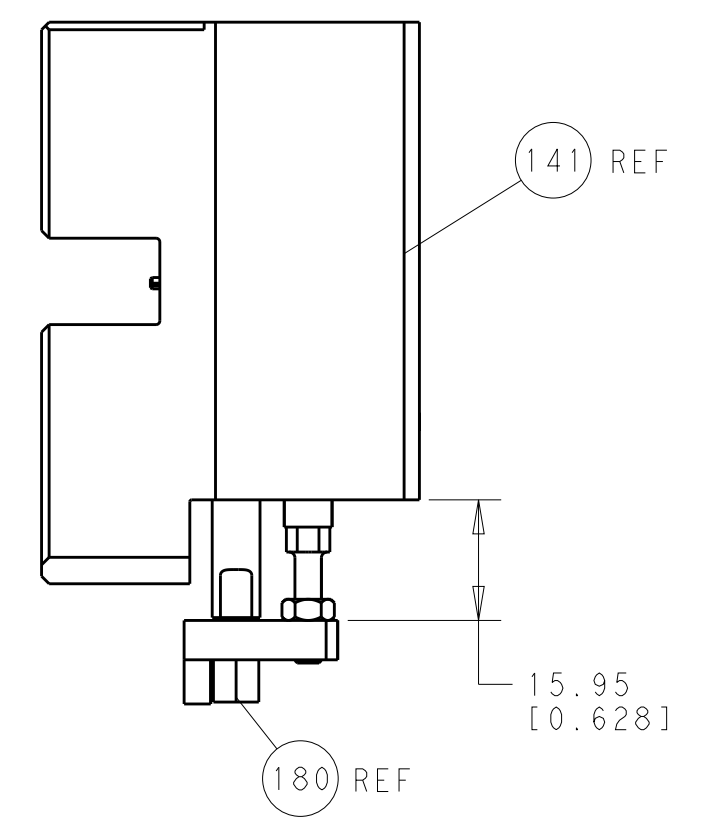

HOLDDOWN SET-UP

FEED TYPE  
MECHANICAL

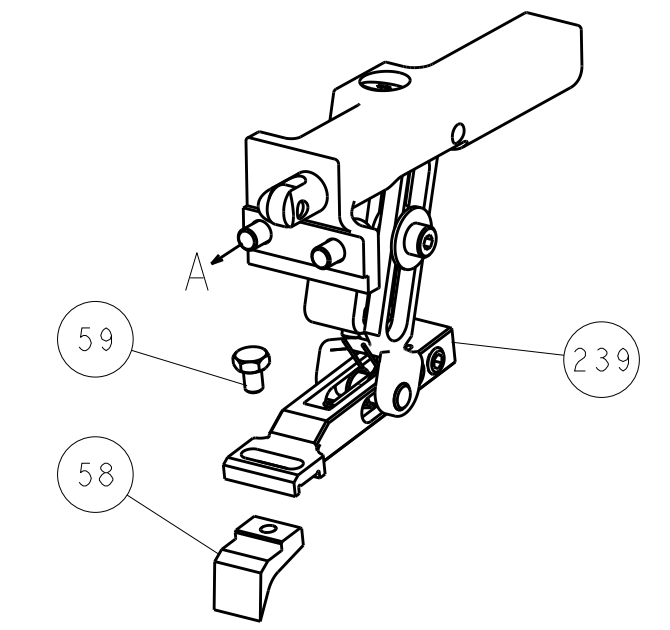

PNEUMATIC

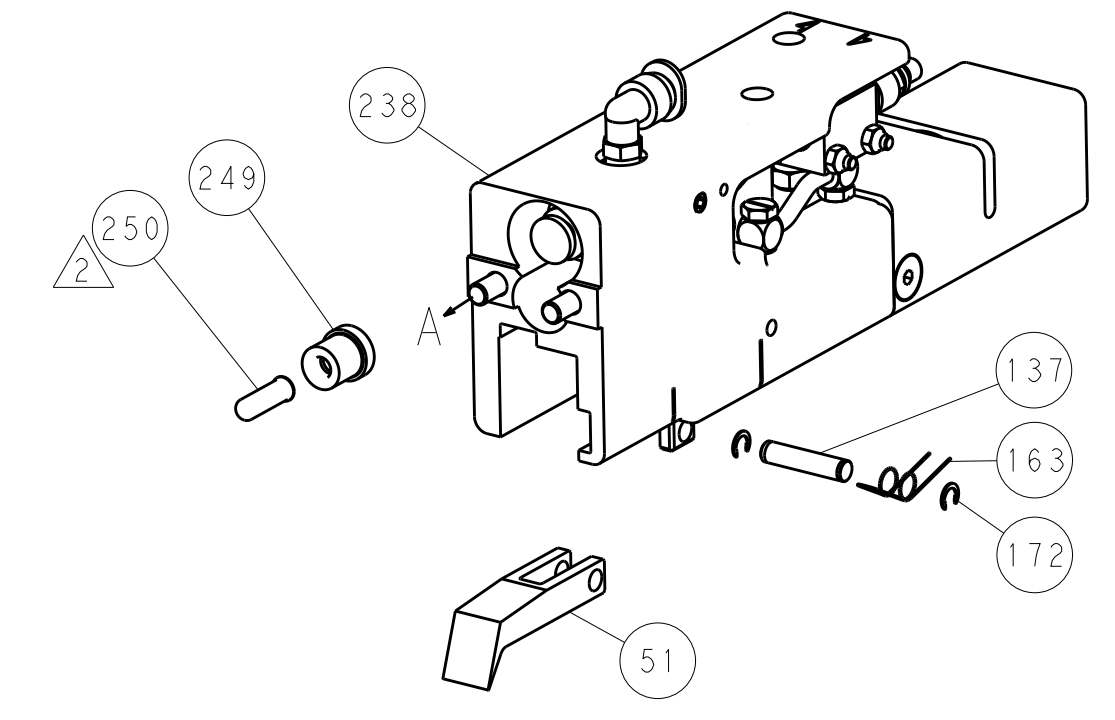

SERVO  
LATCH PLATE

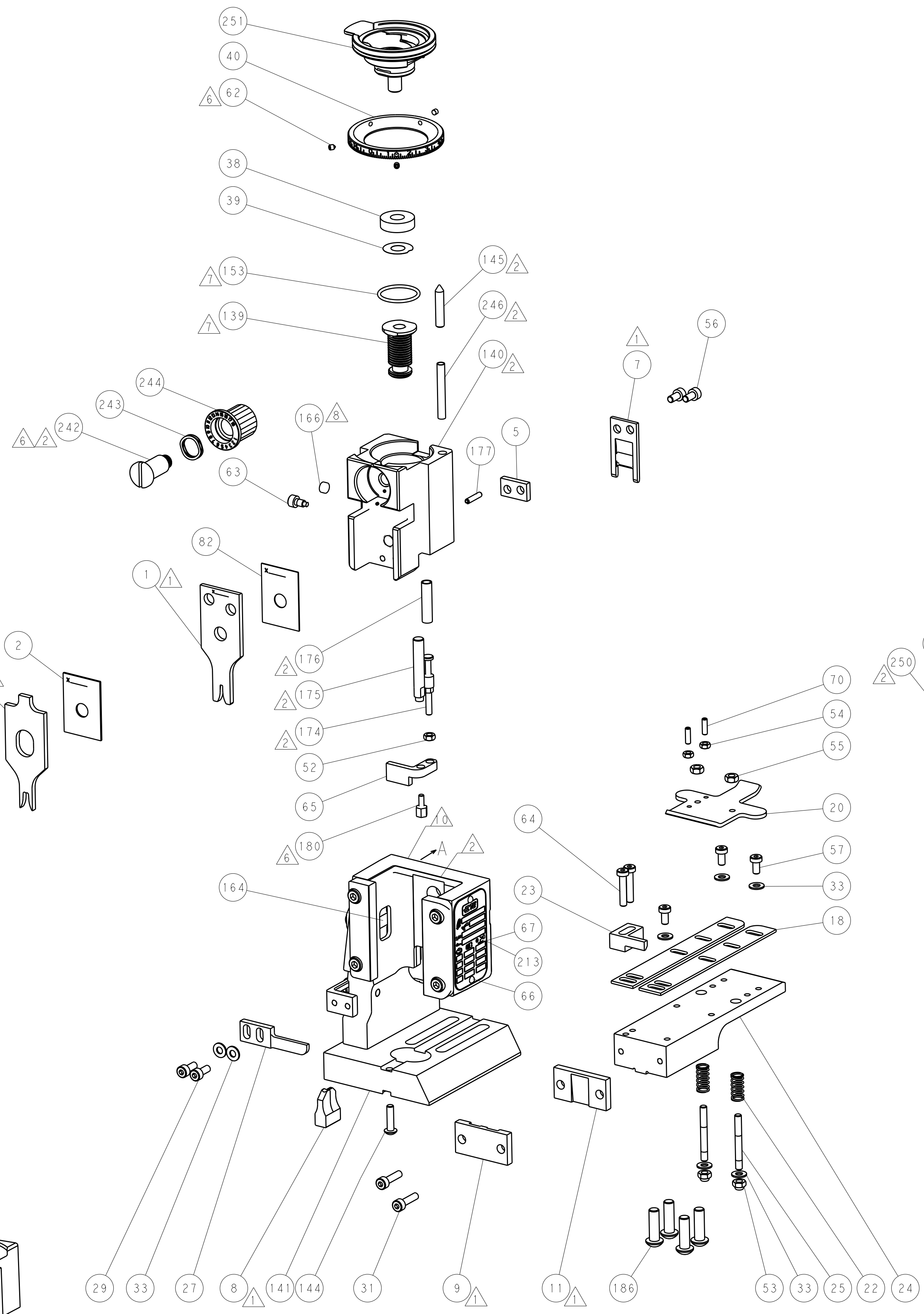
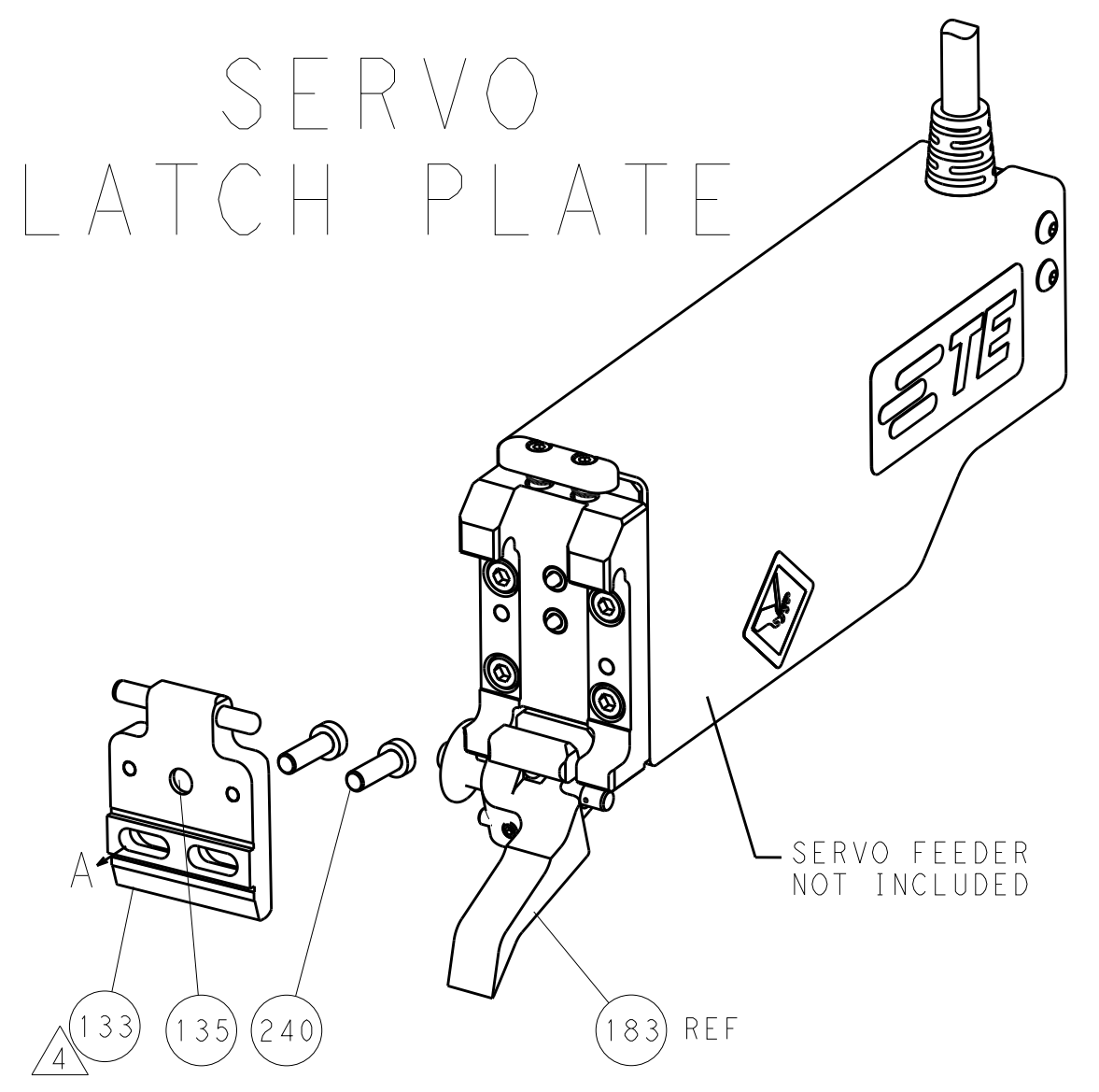

CAM POSITIONS

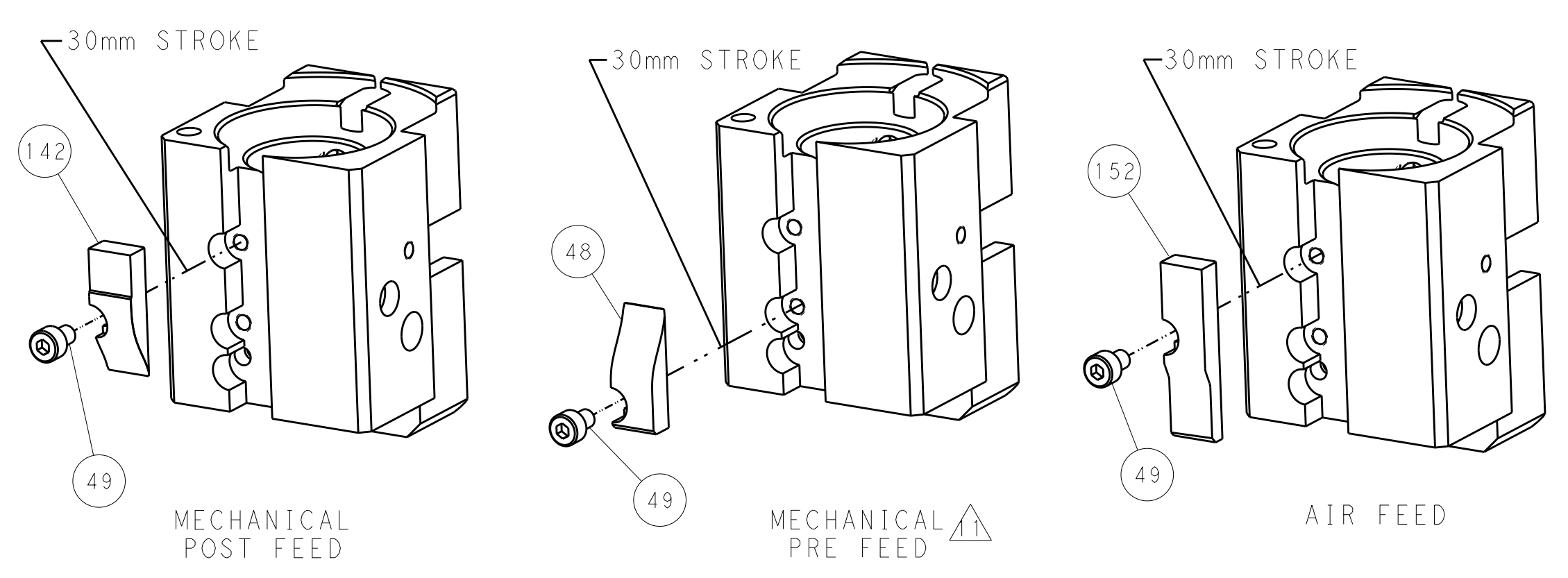

PACIFIC VERSION  
Shown on sheets 3 of 4 & 4 of 4  
(Atlantic version shown on sheets 1 of 4 & 2 of 4)

DIMENSIONS:		TOLERANCES UNLESS OTHERWISE SPECIFIED:		DWG: L.C. CHEN 20JUN2013		CHK: U. GUO 20JUN2013		APVD: J. CRUZ 20JUN2013		NAME: Ocean End Feed Applicator	
mm	0 PLC ±0.5	1 PLC ±0.13	3 PLC ±0.013	4 PLC ±0.0013	ANGLES	FINISH	WEIGHT	SCALE	SHEET	OF	REV
MATERIAL								1:1	4	4	A
Customer Accessible Production Drawing								RESTRICTED TO			