

ATLANTIC VERSION TERMINATOR INTERFACE ADAPTER	PART NUMBER	REVISION	DESCRIPTION	FEED TYPE	CONVERT TO	PART NUMBERS REQUIRED					
	2150325-1	C	FINE CRIMP HEIGHT ADJUST	MECHANICAL	PNEUMATIC FEED	2119950-1	2119792-2	-	2119641-1	-	2063440-1
	2150325-2	C	FINE CRIMP HEIGHT ADJUST	PNEUMATIC	SERVO LATCH PLATE	2119951-1	1901697-1	8-2150325-5	-	-	2168400-7 (QUANTITY 2)
					SMART APPLICATOR	2161326-1	-	8-2150325-4	-	-	-
					MECHANICAL FEED	2119949-1	2063961-1	5-18022-5	2119653-1	-	-
	2150325-5	C	FINE CRIMP HEIGHT ADJUST	SERVO LATCH PLATE	SERVO LATCH PLATE	2119951-1	1901697-1	8-2150325-5	-	-	2168400-7 (QUANTITY 2)
					SMART APPLICATOR	2161326-1	-	8-2150325-4	-	-	-
	2150325-6	C	NON-CRIMP HEIGHT ADJUST	SERVO LATCH PLATE	MECHANICAL FEED	2119949-1	2063961-1	5-18022-5	2119653-1	-	-
2150325-7	C	FINE CRIMP HEIGHT ADJUST	PNEUMATIC FEED		2119950-1	2119792-2	-	2119641-1	-	2063440-1	
7-2150325-7	A	CRIMP TOOLING KIT	-	-	-	-	-	-	-	-	

APPLICATOR DATA		
CRIMP	SIZE	TYPE
WIRE	1.57 mm [.062]	F
INSUL	3.56 mm [.140]	F
APPLICATOR INSTRUCTIONS 408-10390		

TERMINAL DATA: TE TERMINAL		TE CRIMP SPECIFICATION
TERMINAL NAME: RECEPTACLE, POSITIVE LOCK, 110 SERIES		
WIRE STRIP LENGTH		INSULATION DIAMETER RANGE
3.62-4.00 mm [.143-.157 IN]		Ø2.03-3.05 mm [.080-.120 IN]
TERMINAL APPLICATION SPECIFICATION	114-2074	-
TERMINALS APPLIED		
TE TERMINAL	TE TERMINAL	TE TERMINAL
1742975-1		

WIRE SIZE	CRIMP HEIGHT mm [INCH]	CRIMP HEIGHT REFERENCE SETTING
18 AWG	1.24+/-0.05 [.049+/- .002]	4.7
20 AWG	1.09+/-0.05 [.043+/- .002]	6.3
22 AWG	0.99+/-0.05 [.039+/- .002]	7.3

- 1 RECOMMENDED SPARE PARTS
- 2 GREASE BEARING SURFACES LIGHTLY
- 3 LUBRICATE DAILY PER THE APPLICATOR INSTRUCTION SHEET SUPPLIED WITH THE APPLICATOR.
- 4 APPLICATOR SPECIFIC DATA TO BE ENTERED INTO BLANK MEMORY CHIP AT ASSEMBLY. SEE BELOW FOR PART NUMBER:
 MECHANICAL FEED WITH "SMART APPLICATOR" CONVERSION: 8-2150325-4
 PNEUMATIC FEED WITH "SMART APPLICATOR" CONVERSION: 8-2150325-4
 SERVO FEED WITH "FINE CRIMP HEIGHT ADJUST": 8-2150325-5
 SERVO FEED WITH "NON-CRIMP HEIGHT ADJUST": 8-2150325-6
- 5. ADJUSTMENT OF THE STRIPPER MAY BE REQUIRED WHEN MOVING THE APPLICATOR BETWEEN BENCH AND LEADMAKER APPLICATIONS.
- 6 APPLY PART NUMBER 1-23419-5 LOCTITE TO THREADS OF ITEMS 50 & 62. APPLY PART NUMBER 2-23419-6 LOCTITE TO THREADS OF ITEM 242. FOR -6 ONLY APPLY PART NUMBER 1-23419-5 LOCTITE TO THREADS OF ITEMS 37.
- 7 GREASE THREADS, GROOVE AND O-RING ON ITEMS 35 & 252.
- 8 MAGNET, ITEM 166 MUST BE ORIENTED CORRECTLY IN ORDER TO PROPERLY ACTUATE THE COUNTER.
- 9 CRIMP HEIGHT REFERENCE SETTING WAS THE SETTING USED WHEN THE APPLICATOR WAS QUALIFIED AT THE FACTORY. ADJUSTMENT MAY BE NECESSARY WHEN RUNNING APPLICATOR IN THE FIELD.
- 10 SPARE FEED CAM STORAGE LOCATION REFER TO INSTRUCTION SHEET FOR ADDITIONAL INFORMATION.
- 11 THE RECOMMENDED SET-UP FOR END FEED APPLICATORS IS POST-FEED WITH ITEM 2119653-1. THE APPLICATOR CAN BE CONFIGURED FOR PRE-FEED WITH ITEM 2119652-1 BUT MAY ENCOUNTER PROBLEMS WITH SOME APPLICATIONS. FEED ISSUES OR TERMINAL JAMMING MAY OCCUR IN THE PRE-FEED CONFIGURATION.
- 12 WHEN ASSEMBLING -6 NON-CRIMP HEIGHT ADJUST APPLICATOR USE SHIM PACK 2119957-2 TO ALIGN APPLICATOR'S MAXIMUM WIRE CRIMP HEIGHT AT NORMAL TERMINATOR SHUT HEIGHT

***WARNING**
 ON INSTALLATION, SET WIRE DISC, ITEM 40 TO LARGEST WIRE SIZE SETTING. USE OF SETTINGS BELOW MINIMUM REQUIRED CRIMP HEIGHT SETTING WILL CAUSE DAMAGE TO CRIMP TOOLING.

-77	-7	-6	-5	-2	-1	PART NO	DESCRIPTION	ITEM NO
-	-	1	-	-	-	2119957-2	APPLICATOR SHIM PACK	260
-	1	-	1	1	1	8-21084-0	O-RING, .676 ID, .070 DIA. MAT.	252
-	-	-	-	1	-	2119640-1	PUSH ROD, AIR FEED	250
-	-	-	-	1	-	1803259-1	BUSHING, FLANGED	249
-	-	-	-	1	-	2119641-1	FEED CAM, AIR FEED	248
-	1	-	1	1	1	2119798-1	DETENT PIN	247
-	1	-	1	1	1	1-22279-3	SPRING, COMPRESSION	246

ATLANTIC VERSION
 Shown on sheets 1 of 4 & 2 of 4
 (Pacific version shown on sheets 3 of 4 & 4 of 4)

SET UP GAUGE	LOC	DIST	REVISIONS					
2119599-2	A	66	P	LTN	DESCRIPTION	DATE	OWN	APVD
			B		ECR-14-006200	25APR2014	LG	TE
			C		ECR-17-011879	16AUG2017	TB	GB

-	-	1	-	-	-	2119759-1	RAM, AMP STYLE, END FEED, NON-ADJUST	245
-	1	1	1	1	1	2119082-9	CAM, SNAIL, INSULATION ADJUSTMENT	244
-	1	1	1	1	1	2079764-1	WASHER, WAVE SPRING, CREST-TO-CREST	243
-	1	1	1	1	1	2119083-1	RETAINER, INSULATION DIAL	242
-	-	2	2	-	-	2168400-7	SHCS, LOW HEAD, RoHS, M5 X 10	240
-	-	-	-	-	1	2119580-1	MECHANICAL FEED ASSEMBLY	239
-	-	-	-	1	-	2063440-1	AIR FEED MODULE	238
-	-	1	1	-	-	2119740-2	TAG, IDENTIFICATION	213
-	-	REF	REF	-	-	1901697-1	FEED FINGER ASSEMBLY, EF	183
-	1	1	1	1	1	6-993111-6	PIN, SLOTTED SPRING 3.0 X 14.0	177
-	1	1	1	1	1	8-22280-7	SPRING, COMPRESSION	176
-	1	1	1	1	1	1752353-2	GUIDE PIN, HOLDDOWN	175
-	1	1	1	1	1	1901680-2	GUIDE PIN, HOLDDOWN	174
-	-	-	-	2	-	21045-3	RING, RETAIN, EXTERN, 3/16 CRESCENT	172
-	1	1	1	1	1	994969-1	MAGNET, RARE EARTH HIGH ENERGY	166
-	REF	REF	REF	REF	REF	994970-2	COUNTER, MAGNETIC	164
-	-	-	-	1	-	240638-1	SPRING, FEED FINGER	163
-	-	-	-	1	-	3-23627-7	PIN, RETAIN, GRVD, 3/16 X .854	137
-	-	REF	REF	-	-	SEE NOTE 4	MEMORY CHIP, PROGRAMMED	135
-	-	1	1	-	-	1633743-1	SERVO FEED LATCH ASM	133
-	1	1	1	1	1	455888-6	SPACER, CRIMPER	82
-	1	1	1	1	1	2119956-2	DOCUMENTATION PACKAGE	71
-	2	2	2	2	2	2-18032-2	SCR, SET, FLT PNT, M3 X 10.0	70
-	1	-	-	1	1	2119740-1	TAG, IDENTIFICATION	67
-	2	2	2	2	2	2168078-1	SCREW, DRIVE, RH, RoHS, 2 x .188	66
-	1	1	1	1	1	1901681-5	HOLDDOWN, TERMINAL	65
-	2	2	2	2	2	2168400-5	SHCS, LOW HEAD, RoHS, M4 X 20	64
-	1	-	1	1	1	2119793-1	LIMITER, ADJUSTMENT BOLT	63
-	3	-	3	3	3	992763-5	SCR, SET, SOC, CONE PNT, M3 X 4.0	62
-	1	1	1	1	1	2079383-4	SCR, BHSC, RoHS (M4 X 8)	60
-	-	-	-	-	1	5-18022-5	SCR, HEX HD CAP, M4 X 6.0	59
-	-	-	-	-	1	2063961-1	FEED FINGER	58
-	3	3	3	3	3	2168400-4	SHCS, LOW HEAD, RoHS, M4 X 8	57
-	2	2	2	2	2	2168083-2	SCR, SKT HD CAP, RoHS, M4 X 8.0	56
-	2	2	2	2	2	5018030-2	NUT, HEX, REG, RoHS, M4	55
-	2	2	2	2	2	5018030-1	NUT, HEX, REG, RoHS, M3	54
-	2	2	2	2	2	986965-8	NUT, LOCK, HEX, TORQUE (M4)	53
-	1	1	1	1	1	1-5018030-0	NUT, HEX, REG, RoHS, M3.5	52
-	-	-	-	1	-	2119792-2	PAWL, EF, AIR	51
-	1	1	1	1	1	1-1976055-6	STANDOFF, HOLD-DOWN	50
-	-	-	-	1	2	18023-9	SCR, SKT HD CAP M4 X 6.0	49
-	-	-	-	-	1	2119652-1	FEED CAM, PRE FEED	48
-	-	-	-	-	1	2119653-1	FEED CAM, POST FEED	47
-	1	1	1	1	1	2119655-5	APPLICATOR BASIC ASSEMBLY, EF	46
-	1	-	1	1	1	2119369-1	RAM, AMP STYLE, END FEED	44
-	1	1	1	1	1	2079383-7	SCR, BHSC, RoHS (M8 X 25)	41
-	1	-	1	1	1	2119645-1	DISC, NUMBERED FA WIRE ADJUSTMENT	40
-	1	-	1	1	1	2119957-1	APPLICATOR SHIM PACK	39
-	1	1	1	1	1	2119644-1	RAM WASHER, PRECISION	38
-	1	1	1	1	1	2119085-1	FA HEAD, ATLANTIC STYLE	37
-	1	-	1	1	1	2119092-1	BOLT, ADJUSTMENT	35
-	7	7	7	7	7	1-18028-2	WASHER, FLAT, REG M4	33
-	2	2	2	2	2	2168083-9	SCR, SKT HD CAP, RoHS, M4 X 20	31
-	2	2	2	2	2	1-2168083-0	SCR, SKT HD CAP, RoHS, M4 X 10	29
-	1	1	1	1	1	240639-1	STRIPPER (MACHINING)	27
-	2	2	2	2	2	1320906-1	STUD, THREADED	25
-	1	1	1	1	1	1752371-5	PLATE, STRIP GUIDE	24
-	1	1	1	1	1	240825-1	PLATE, STRIP HOLD DOWN	23
-	2	2	2	2	2	2-22281-3	SPRING, COMPRESSION	22
-	1	1	1	1	1	1752373-4	DRAG	20
-	2	2	2	2	2	1901259-5	GUIDE, LOWER STRIP	18
-	4	4	4	4	4	1-2079383-1	SCR, BHSC, RoHS (M6 X 12)	17
-	1	1	1	1	1	240644-1	PLATE, REAR SHEAR	11
-	1	1	1	1	1	1338016-3	TAB, LATCHING	10
-	1	1	1	1	1	690482-6	PLATE, FRONT SHEAR	9
1	1	1	1	1	1	1803059-2	ANVIL, COMBINATION, END FEED	8
-	1	1	1	1	1	2217206-6	BLADE, SLUG	7
-	-	-	-	-	-	-	-	6
-	1	1	1	1	1	2-240641-0	SPACER	5
-	1	1	1	1	1	2-238009-3	BLOCK, FL CRIMPER SPACER	4
1	1	1	1	1	1	2-2119582-4	CRIMPER, INSULATION F PREMIUM	3
-	1	1	1	1	1	455888-7	SPACER, CRIMPER	2
1	1	1	1	1	1	2-456403-1	CRIMPER, WIRE PREMIUM	1

DIMENSIONS:		TOLERANCES UNLESS OTHERWISE SPECIFIED:		DATE		NAME	
mm	0 PLC ±	1 PLC ±	2 PLC ±	3 PLC ±	4 PLC ±	5 PLC ±	6 PLC ±
	ANGLES	FINISH					
MATERIAL		WEIGHT		SIZE	CAGE CODE	DRAWING NO	RESTRICTED TO
				A1	00779	2150325	
Customer Accessible Production Drawing				SCALE	1:1	SHEET	1 of 4

LOC		DIST		REVISIONS			
A	66	P	LTM	DESCRIPTION	DATE	OWN	APVD
		-		SEE SHEET 1			

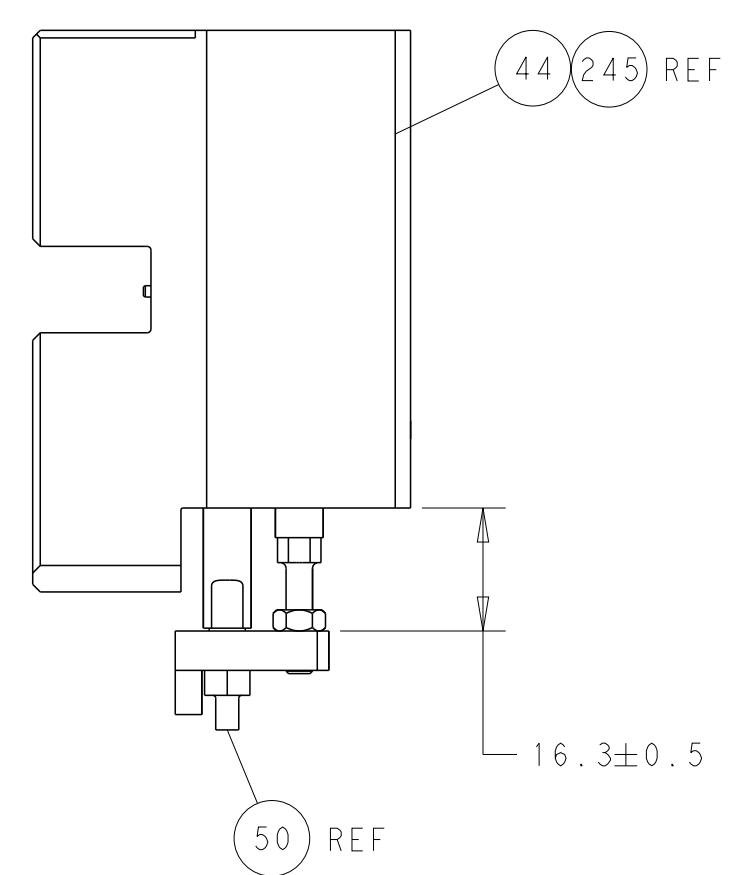

HOLDDOWN SET-UP

FEED TYPE
MECHANICAL

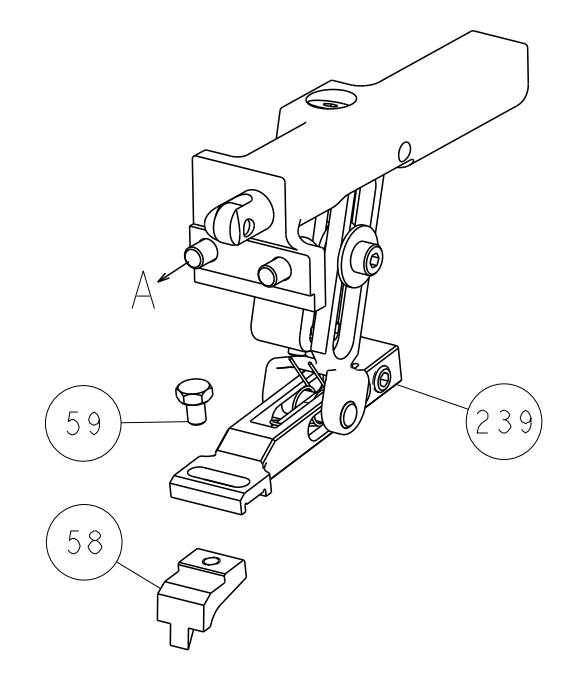

PNEUMATIC

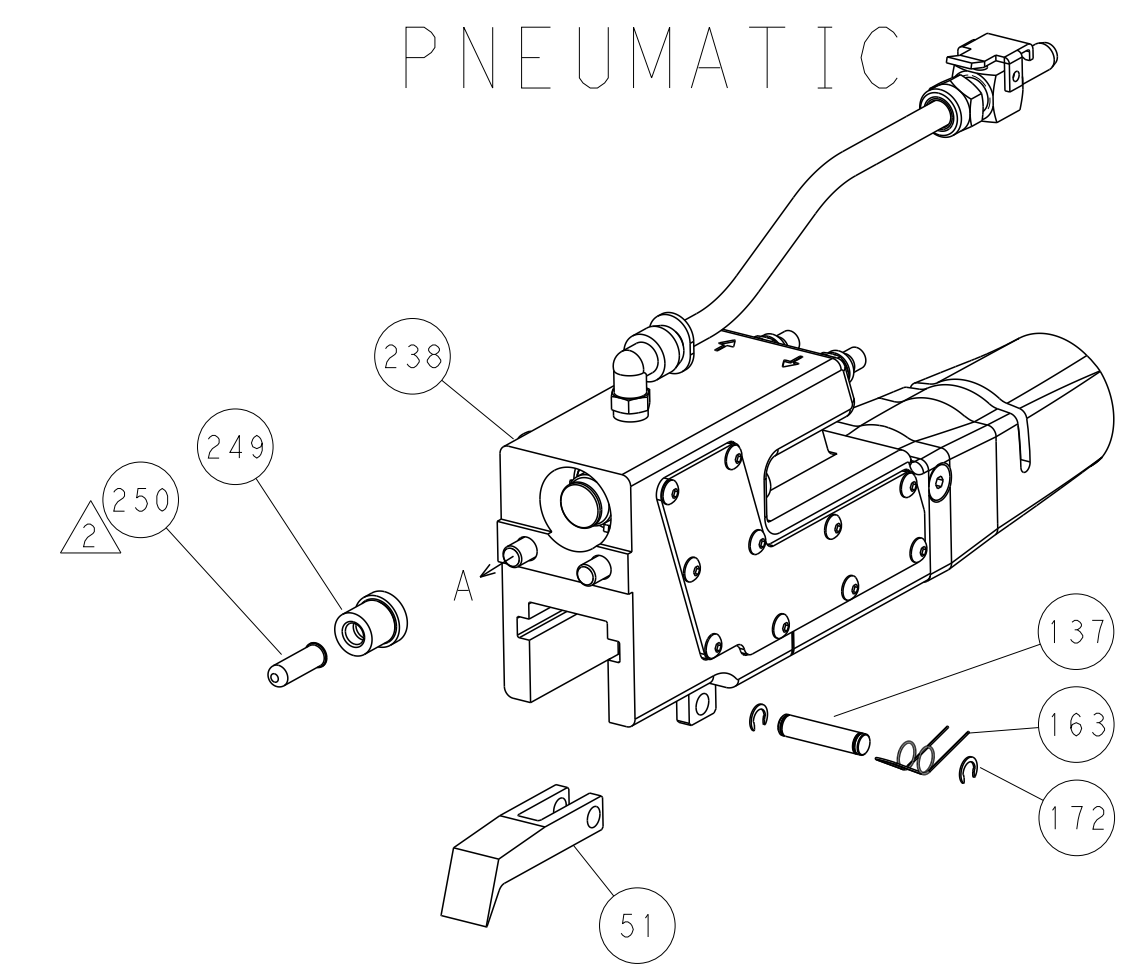

SERVO
LATCH PLATE

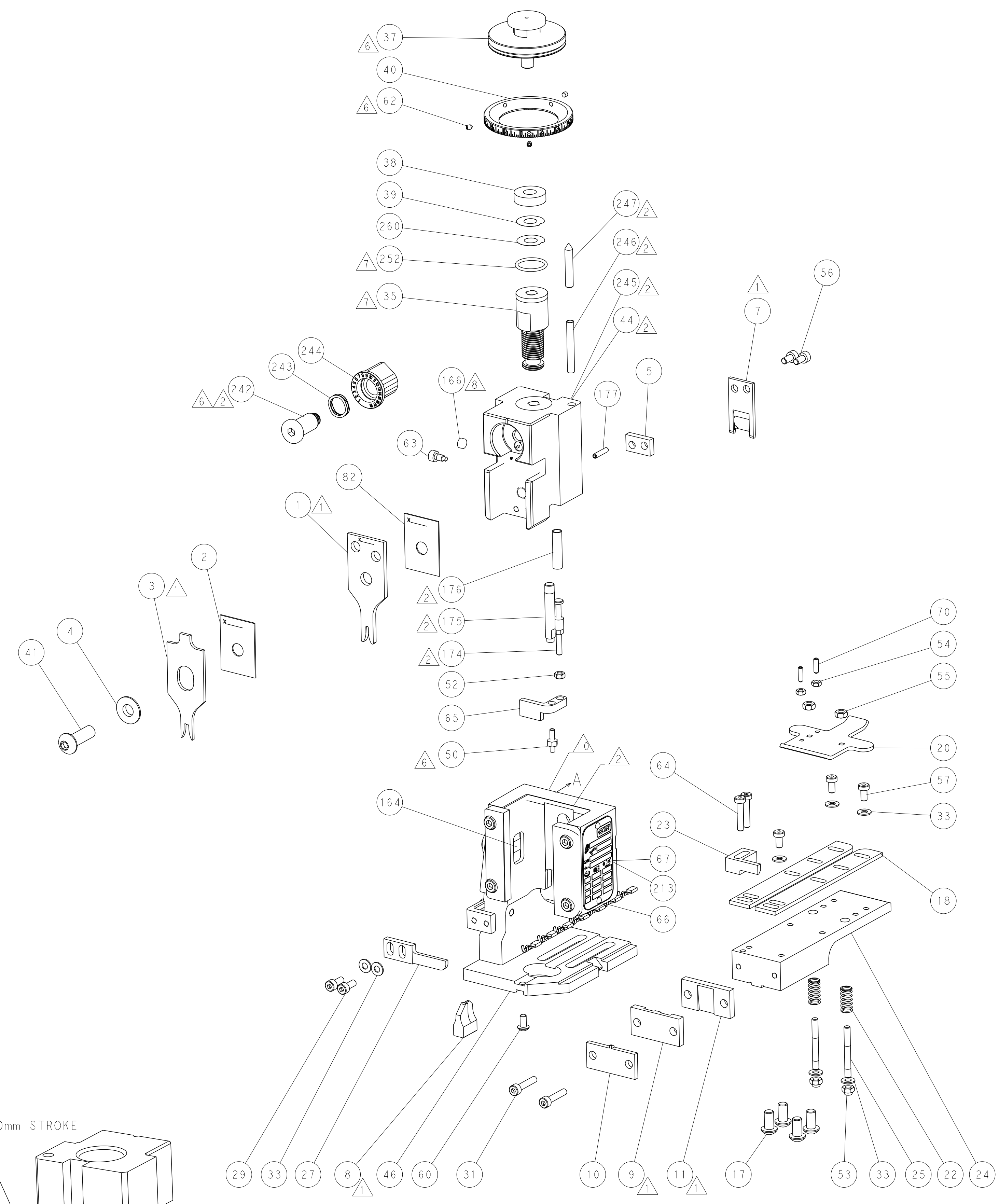
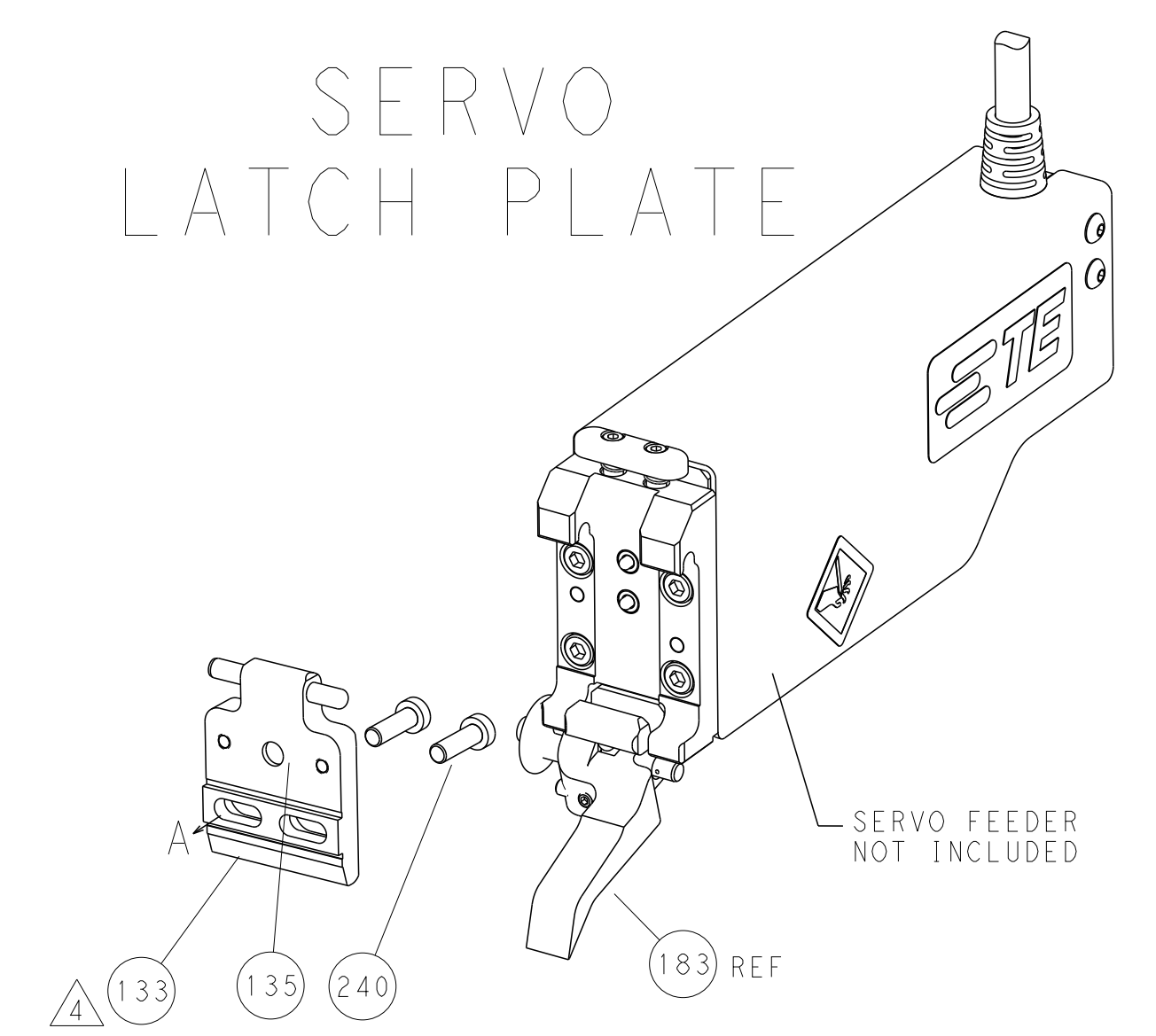

CAM POSITIONS

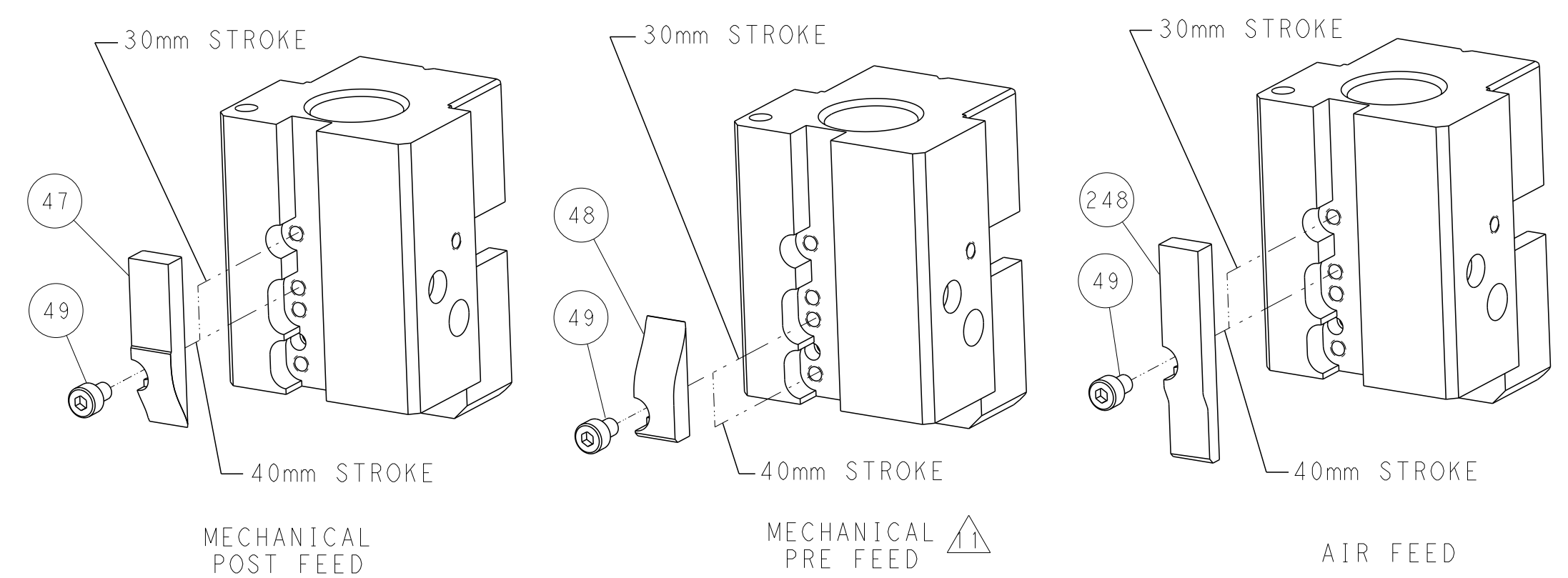

ATLANTIC VERSION
 Shown on sheets 1 of 4 & 2 of 4
 (Pacific version shown on sheets 3 of 4 & 4 of 4)

DIMENSIONS:		TOLERANCES UNLESS OTHERWISE SPECIFIED:		DWG: K. STAKEM 2 MARCH 2013		TE Connectivity	
mm		0 PLC ±		CHK: G. BAILEY 2 MARCH 2013		Harrisburg, PA 17105-3608	
Ø		1 PLC ±		APVD: T. ELBLIN 2 MARCH 2013		NAME: Ocean End Feed Applicator	
H		2 PLC ±		PRODUCT SPEC:		SIZE: CAGE CODE: DRAWING NO:	
D		3 PLC ±		APPLICATION SPEC:		RESTRICTED TO:	
R		4 PLC ±		WEIGHT:		A1 00779 ©=2150325	
S		5 PLC ±		MATERIAL:		SCALE: 1:1 SHEET 2 OF 4 REV C	
T		6 PLC ±		FINISH:		Customer Accessible Production Drawing	
F		7 PLC ±				SHEETS 3 & 4 ARE NOT REQUIRED FOR ATLANTIC VERSION	

PACIFIC VERSION TERMINATOR INTERFACE ADAPTER	PART NUMBER	REVISION	DESCRIPTION	FEED TYPE	APPLICATOR STYLE CONVERSION CHART						
					CONVERT TO	PART NUMBERS REQUIRED					
						PNEUMATIC FEED	2119950-1	2119792-2	-	2119641-2	-
	2-2150325-1	C	FINE CRIMP HEIGHT ADJUST	MECHANICAL	SERVO LATCH PLATE	2119951-1	1901697-1	8-2150325-5	-	-	2168400-7 (QUANTITY 2)
					SMART APPLICATOR	2161326-1	-	8-2150325-4	-	-	-
					MECHANICAL FEED	2119949-1	2063961-1	5-18022-5	2119653-2	-	-
	2-2150325-2	C	FINE CRIMP HEIGHT ADJUST	PNEUMATIC	SERVO LATCH PLATE	2119951-1	1901697-1	8-2150325-5	-	-	2168400-7 (QUANTITY 2)
					SMART APPLICATOR	2161326-1	-	8-2150325-4	-	-	-
					MECHANICAL FEED	2119949-1	2063961-1	5-18022-5	2119653-2	-	-
	2-2150325-5	C	FINE CRIMP HEIGHT ADJUST	SERVO LATCH PLATE	2119950-1	2119792-2	-	-	2119641-2	-	2063440-1
	2-2150325-7	C	FINE CRIMP HEIGHT ADJUST	NONE	-	-	-	-	-	-	-
	7-2150325-7	A	CRIMP TOOLING KIT	-	-	-	-	-	-	-	-

APPLICATOR DATA		
CRIMP	SIZE	TYPE
WIRE	1.57 mm (.062)	F
INSUL	3.56 mm (.140)	F
APPLICATOR INSTRUCTIONS 408-10390		

TERMINAL DATA: TE TERMINAL		TE CRIMP SPECIFICATION	
TERMINAL NAME: RECEPTACLE, POSITIVE LOCK, 110 SERIES			
WIRE STRIP LENGTH		INSULATION DIAMETER RANGE	
3.62-4.00 mm (.143-.157 IN)		Ø2.03-3.05 mm (.080-.120 IN)	
TERMINAL APPLICATION SPECIFICATION	114-2074	-	-
TERMINALS APPLIED			
TE TERMINAL	TE TERMINAL	TE TERMINAL	TE TERMINAL
1742975-1			

WIRE SIZE	CRIMP HEIGHT mm [INCH]	CRIMP HEIGHT REFERENCE SETTING
18 AWG	1.24 +/- 0.05 [.049 +/- .002]	4.7
20 AWG	1.09 +/- 0.05 [.043 +/- .002]	6.3
22 AWG	0.99 +/- 0.05 [.039 +/- .002]	7.3

- RECOMMENDED SPARE PARTS
- GREASE BEARING SURFACES LIGHTLY
- 3. LUBRICATE DAILY PER THE APPLICATOR INSTRUCTION SHEET SUPPLIED WITH THE APPLICATOR.
- APPLICATOR SPECIFIC DATA TO BE ENTERED INTO BLANK MEMORY CHIP AT ASSEMBLY. SEE BELOW FOR PART NUMBER:
 MECHANICAL FEED WITH "SMART APPLICATOR" CONVERSION: 8-2150325-4
 PNEUMATIC FEED WITH "SMART APPLICATOR" CONVERSION: 8-2150325-4
 SERVO FEED WITH "FINE CRIMP HEIGHT ADJUST": 8-2150325-5
- 5. ADJUSTMENT OF THE STRIPPER MAY BE REQUIRED WHEN MOVING THE APPLICATOR BETWEEN BENCH AND LEADMAKER APPLICATIONS.
- APPLY PART NUMBER 1-23419-5 LOCTITE TO THREADS OF ITEMS 50 & 62. APPLY PART NUMBER 2-23419-6 LOCTITE TO THREADS OF ITEM 242.
- GREASE THREADS, GROOVE AND O-RING ON ITEMS 139 & 153.
- MAGNET, ITEM 166 MUST BE ORIENTED CORRECTLY IN ORDER TO PROPERLY ACTUATE THE COUNTER.
- CRIMP HEIGHT REFERENCE SETTING WAS THE SETTING USED WHEN THE APPLICATOR WAS QUALIFIED AT THE FACTORY. ADJUSTMENT MAY BE NECESSARY WHEN RUNNING APPLICATOR IN THE FIELD.
- SPARE FEED CAM STORAGE LOCATION REFER TO INSTRUCTION SHEET FOR ADDITIONAL INFORMATION.
- THE RECOMMENDED SET-UP FOR END FEED APPLICATORS IS POST-FEED WITH ITEM 2119653-1. THE APPLICATOR CAN BE CONFIGURED FOR PRE-FEED WITH ITEM 2119652-1 BUT MAY ENCOUNTER PROBLEMS WITH SOME APPLICATIONS. FEED ISSUES OR TERMINAL JAMMING MAY OCCUR IN THE PRE-FEED CONFIGURATION.

***WARNING**
 ON INSTALLATION, SET WIRE DISC, ITEM 40 TO LARGEST WIRE SIZE SETTING. USE OF SETTINGS BELOW MINIMUM REQUIRED CRIMP HEIGHT SETTING WILL CAUSE DAMAGE TO CRIMP TOOLING.

-77-27-25-22-21	PART NO	DESCRIPTION	ITEM NO
- 1 1 1 1 1	2119782-1	FINE ADJUST HEAD ASM, PACIFIC STYLE	251
- - - 1 -	2119640-1	PUSH ROD, AIR FEED	250
- - - 1 -	1803259-1	BUSHING, FLANGED	249
- 1 1 1 1 1	1-22279-3	SPRING, COMPRESSION	246
- 1 1 1 1 1	2119082-9	CAM, SNAIL, INSULATION ADJUSTMENT	244

PACIFIC VERSION
 Shown on sheets 3 of 4 & 4 of 4
 (Atlantic version shown on sheets 1 of 4 & 2 of 4)

SET UP GAUGE	LOC	DIST	REVISIONS			
2119599-2	A	66	REV	DATE	BY	APPV
-	-	-	SEE SHEET 1	-	-	-

REV	DATE	BY	APPV	DESCRIPTION	DATE	BY	APPV
- 1 1 1 1	2079764-1			WASHER, WAVE SPRING, CREST-TO-CREST			243
- 1 1 1 1	2119083-1			RETAINER, INSULATION DIAL			242
- - 2 - -	2168400-7			SHCS, LOW HEAD, RoHS, M5 X 10			240
- - - 1 -	2119580-1			MECHANICAL FEED ASSEMBLY			239
- - - 1 -	2063440-1			AIR FEED MODULE			238
- - 1 - -	2119740-2			TAG, IDENTIFICATION			213
- 4 4 4 4	2079383-9			SCR, BHSC, RoHS (M6 X 20)			186
- REF - -	1901697-1			FEED FINGER ASSEMBLY, EF			183
- 1 1 1 1	6-993111-6			PIN, SLOTTED SPRING 3.0 X 14.0			177
- 1 1 1 1	8-22280-7			SPRING, COMPRESSION			176
- 1 1 1 1	1752353-2			GUIDE PIN, HOLDDOWN			175
- 1 1 1 1	1901680-2			GUIDE PIN, HOLDDOWN			174
- - - 2 -	21045-3			RING, RETAIN, EXTERN, 3/16 CRESCENT			172
- 1 1 1 1	994969-1			MAGNET, RARE EARTH HIGH ENERGY			166
- REFREFREFREF	994970-2			COUNTER, MAGNETIC			164
- - - 1 -	240638-1			SPRING, FEED FINGER			163
- 1 1 1 1	8-21084-1			O-RING, .801 ID, .070 DIA. MAT.			153
- - - 1 -	2119641-2			FEED CAM, AIR FEED			152
- 1 1 1 1	2119798-2			DETENT PIN			145
- 1 1 1 1	2079383-8			SCR, BHSC, RoHS (M4 X 16)			144
- - - - 1	2119653-2			FEED CAM, POST FEED			142
- 1 1 1 1	2119655-6			APPLICATOR BASIC ASSEMBLY, EF			141
- 1 1 1 1	2119651-1			RAM, ASIAN STYLE, END FEED			140
- 1 1 1 1	2119092-2			BOLT, ADJUSTMENT			139
- - - 1 -	3-23627-7			PIN, RETAIN, GRVD, 3/16 X .854			137
- REF - -	SEE NOTE 4			MEMORY CHIP, PROGRAMMED			135
- - 1 - -	1633743-1			SERVO FEED LATCH ASM			133
- 1 1 1 1	455888-6			SPACER, CRIMPER			82
- 1 1 1 1	2119956-2			DOCUMENTATION PACKAGE			71
- 2 2 2 2	2-18032-2			SCR, SET, FLT PNT, M3 X 10.0			70
- 1 - 1 1	2119740-1			TAG, IDENTIFICATION			67
- 2 2 2 2	2168078-1			SCREW, DRIVE, RH, RoHS, 2 x .188			66
- 1 1 1 1	1901681-5			HOLDDOWN, TERMINAL			65
- 2 2 2 2	2168400-5			SHCS, LOW HEAD, RoHS, M4 X 20			64
- 1 1 1 1	2119793-1			LIMITER, ADJUSTMENT BOLT			63
- 3 3 3 3	992763-5			SCR, SET, SOC, CONE PNT, M3 X 4.0			62
- - - - 1	5-18022-5			SCR, HEX HD CAP, M4 X 6.0			59
- - - - 1	2063961-1			FEED FINGER			58
- 3 3 3 3	2168400-4			SHCS, LOW HEAD, RoHS, M4 X 8			57
- 2 2 2 2	2168083-2			SCR, SKT HD CAP, RoHS, M4 X 8.0			56
- 2 2 2 2	5018030-2			NUT, HEX, REG, RoHS, M4			55
- 2 2 2 2	5018030-1			NUT, HEX, REG, RoHS, M3			54
- 2 2 2 2	986965-8			NUT, LOCK, HEX, TORQUE (M4)			53
- 1 1 1 1	1-5018030-0			NUT, HEX, REG, RoHS, M3.5			52
- - - 1 -	2119792-2			PAWL, EF, AIR			51
- 1 1 1 1	1-1976055-6			STANDOFF, HOLD-DOWN			50
- - - 1 2	18023-9			SCR, SKT HD CAP M4 X 6.0			49
- - - - 1	2119652-1			FEED CAM, PRE FEED			48
- 1 1 1 1	2079383-7			SCR, BHSC, RoHS (M8 X 25)			41
- 1 1 1 1	2119645-1			DISC, NUMBERED FA WIRE ADJUSTMENT			40
- 1 1 1 1	2119957-1			APPLICATOR SHIM PACK			39
- 1 1 1 1	2119644-1			RAM WASHER, PRECISION			38
- 7 7 7 7	1-18028-2			WASHER, FLAT, REG M4			33
- 2 2 2 2	2168083-9			SCR, SKT HD CAP, RoHS, M4 X 20			31
- 2 2 2 2	1-2168083-0			SCR, SKT HD CAP, RoHS, M4 X 10			29
- 1 1 1 1	240639-1			STRIPPER (MACHINING)			27
- 2 2 2 2	1320906-1			STUD, THREADED			25
- 1 1 1 1	1752371-5			PLATE, STRIP GUIDE			24
- 1 1 1 1	240825-1			PLATE, STRIP HOLD DOWN			23
- 2 2 2 2	2-22281-3			SPRING, COMPRESSION			22
- 1 1 1 1	1752373-4			DRAG			20
- 2 2 2 2	1901259-5			GUIDE, LOWER STRIP			18
- 1 1 1 1	240644-1			PLATE, REAR SHEAR			11
- 1 1 1 1	1338016-3			TAB, LATCHING			10
- 1 1 1 1	690482-6			PLATE, FRONT SHEAR			9
1 1 1 1 1	1803059-2			ANVIL, COMBINATION, END FEED			8
- 1 1 1 1 1	2217206-6			BLADE, SLUG			7
- - - - -	-			-			6
- 1 1 1 1 1	2-240641-0			SPACER			5
- 1 1 1 1 1	2-238009-3			BLOCK, FL CRIMPER SPACER			4
1 1 1 1 1	2-2119582-4			CRIMPER, INSULATION F PREMIUM			3
- 1 1 1 1 1	455888-7			SPACER, CRIMPER			2
1 1 1 1 1	2-456403-1			CRIMPER, WIRE PREMIUM			1

DIMENSIONS:		TOLERANCES UNLESS OTHERWISE SPECIFIED:		DATE		NAME	
mm	0 PLC ±	1 PLC ±	2 PLC ±	3 PLC ±	4 PLC ±	5 PLC ±	ANGLES ±
MATERIAL:				WEIGHT:	SCALE:	SHEET:	REV:
Customer Accessible Production Drawing				SCALE: 1:1	SHEET: 3 OF 4	REV: C	

LOC		DIST		REVISIONS			
A	66	P	LTN	DESCRIPTION	DATE	DMN	APVD
		-		SEE SHEET 1			

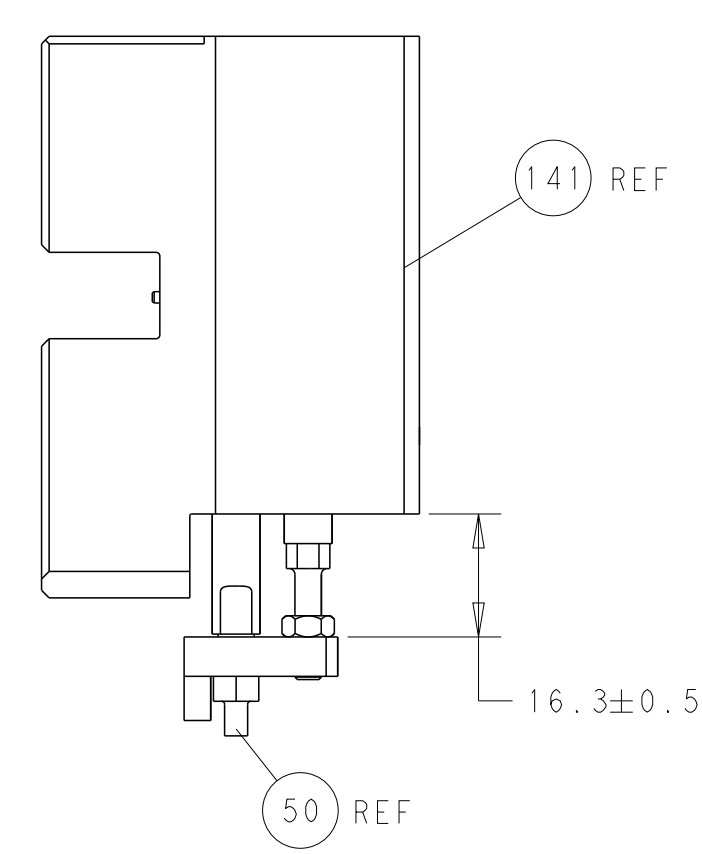

HOLDDOWN SET-UP

FEED TYPE
MECHANICAL

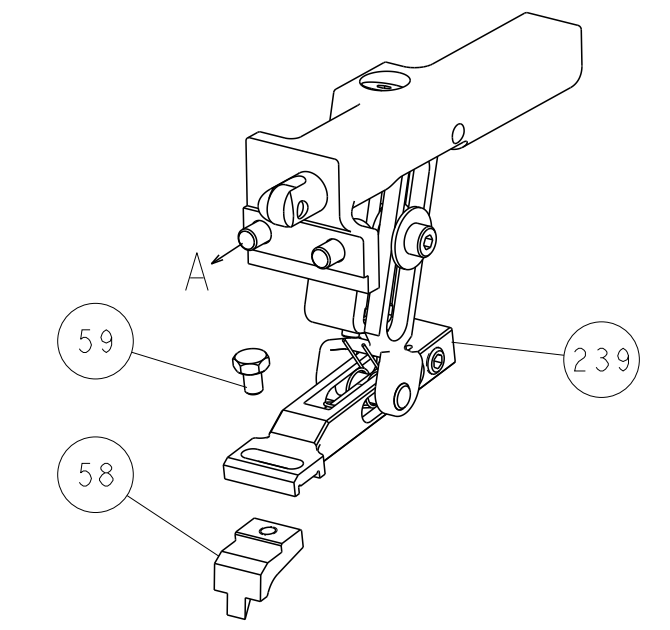

PNEUMATIC

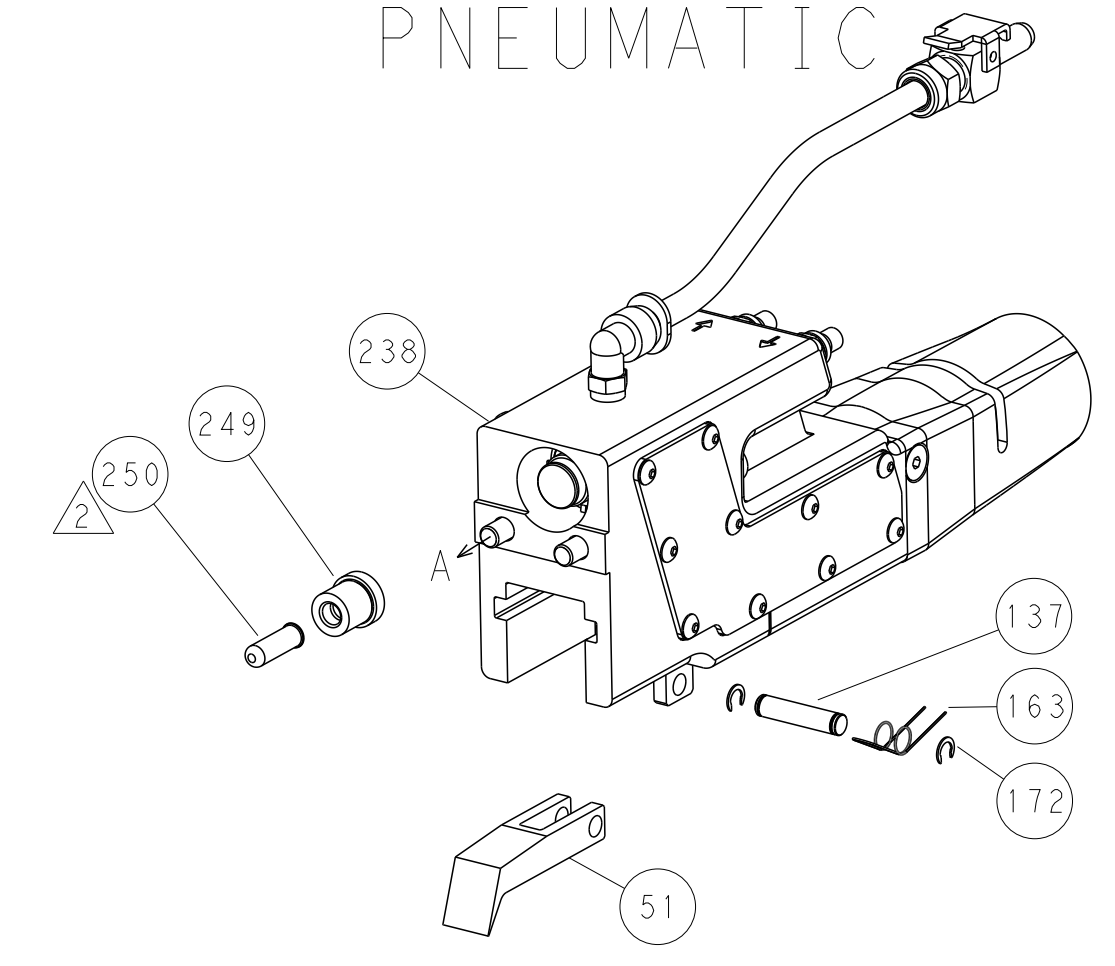

SERVO
LATCH PLATE

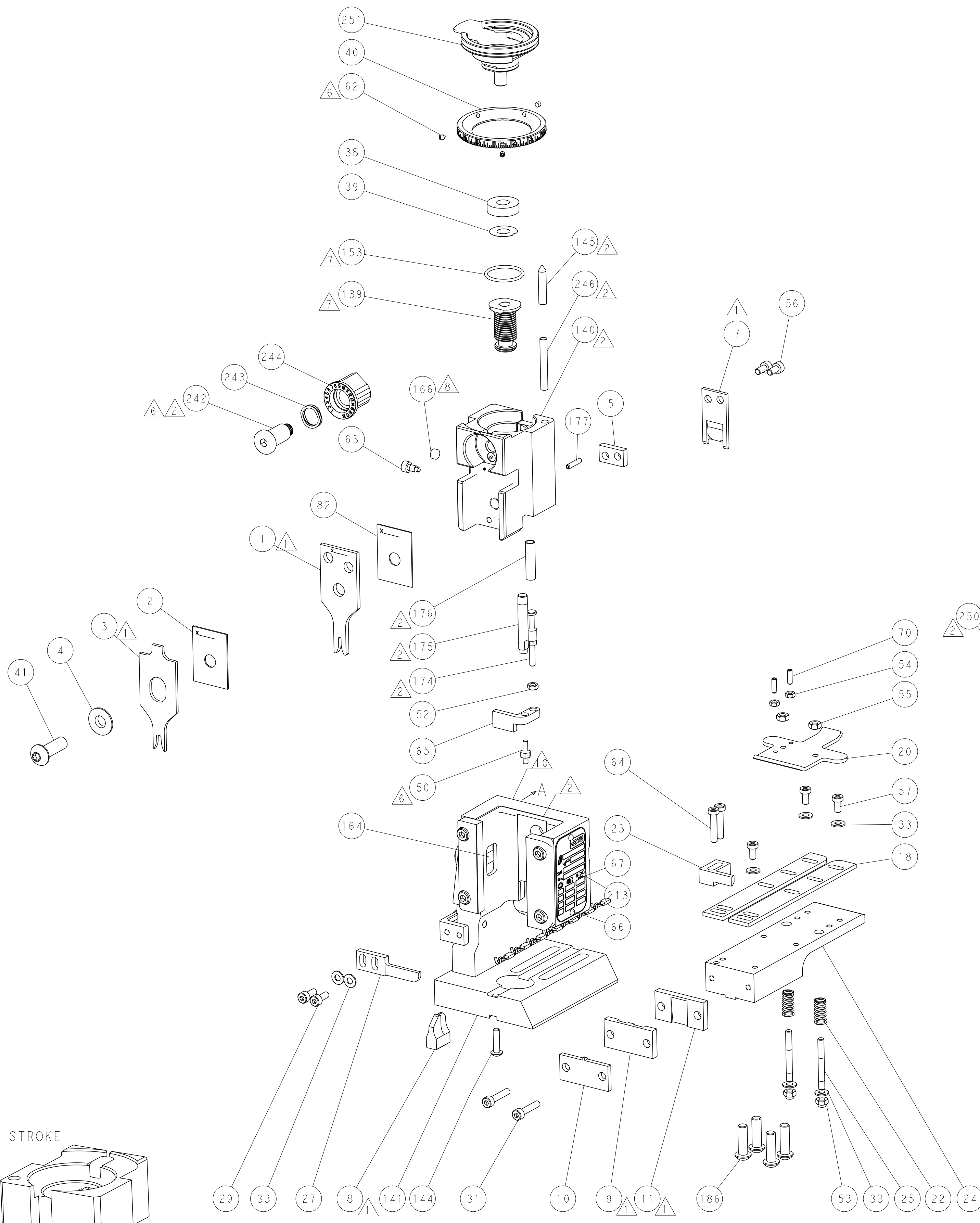
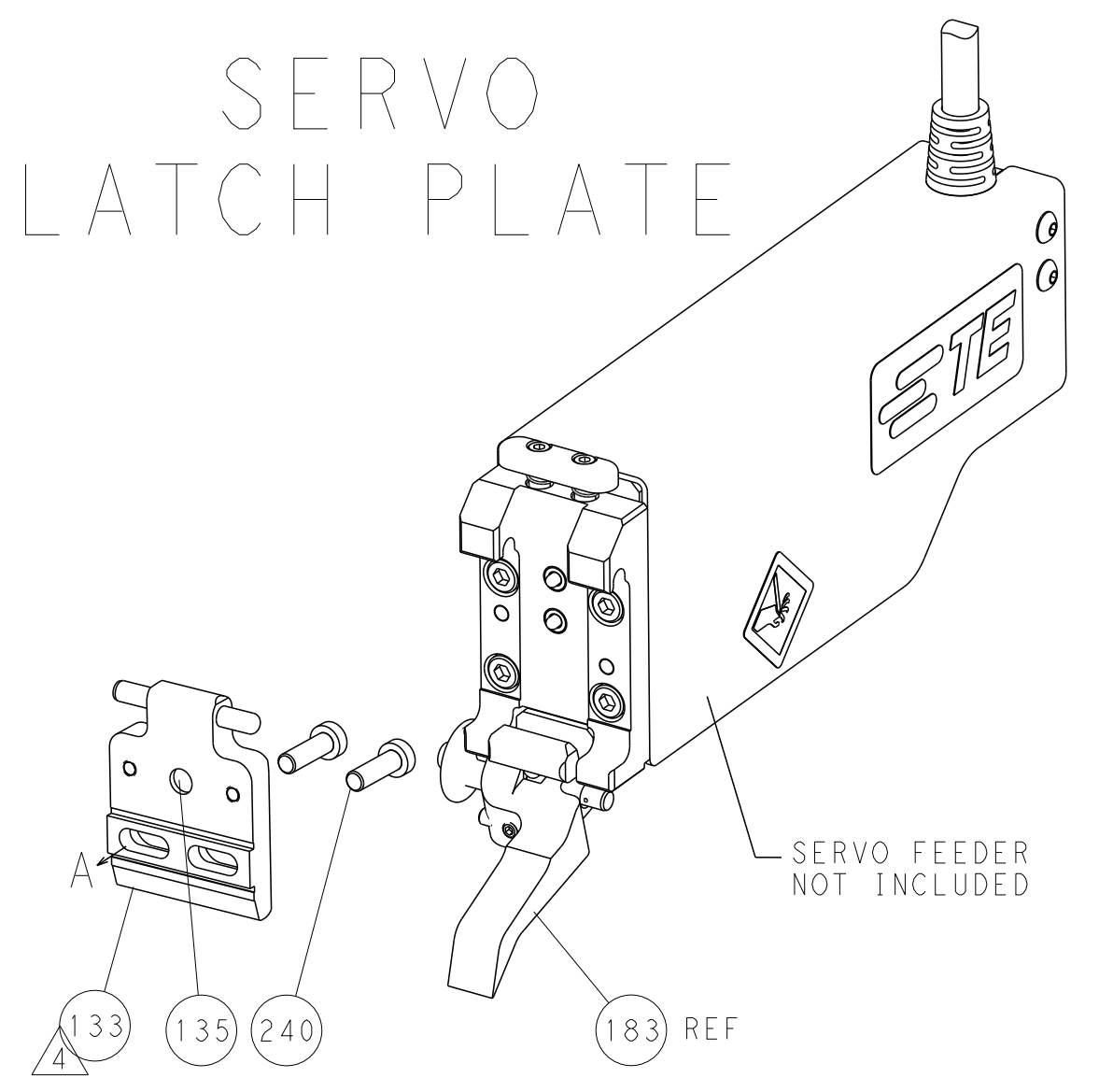

CAM POSITIONS

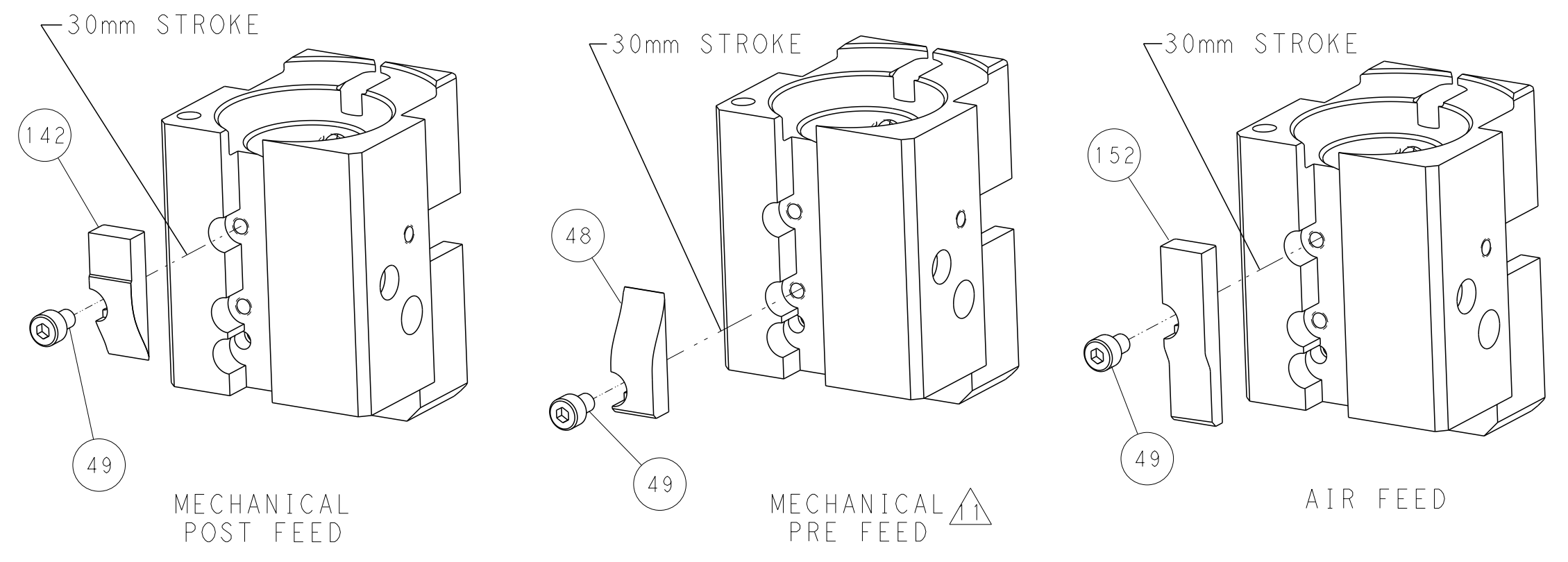

PACIFIC VERSION
 Shown on sheets 3 of 4 & 4 of 4
 (Atlantic version shown on sheets 1 of 4 & 2 of 4)

DIMENSIONS:		TOLERANCES UNLESS OTHERWISE SPECIFIED:		DWG: STAKEM 2MARCH2013		TE Connectivity	
mm	0 PLC	±		CHK: G. BAILEY 12MARCH2013	NAME: Ocean End Feed Applicator		Harrisburg, PA 17105-3608
	1 PLC	±		APVD: T. ELRLIN 12MARCH2013	SIZE: A1		CAGE CODE: 00779
	2 PLC	±		PRODUCT SPEC	DRAWING NO: C-2150325		RESTRICTED TO
	3 PLC	±		APPLICATION SPEC	SCALE: 1:1		SHEET 4 OF 4
	4 PLC	±		WEIGHT	REV: C		
	ANGLES	±		Customer Accessible Production Drawing			
	FINISH			SHEETS 1 & 2 ARE NOT REQUIRED FOR PACIFIC VERSION			