

PART NUMBER	REVISION	DESCRIPTION	FEED TYPE
2266565-1	D	FINE CRIMP HEIGHT ADJUST	MECHANICAL
2266565-2	D	FINE CRIMP HEIGHT ADJUST	PNEUMATIC
7-2266565-1	D	MECHANICAL AND CRIMP TOOLING KIT	MECHANICAL
7-2266565-2	D	PNEUMATIC AND CRIMP TOOLING KIT	PNEUMATIC
7-2266565-7	B	CRIMP TOOLING KIT	-

ATLANTIC VERSION TERMINATOR INTERFACE ADAPTER

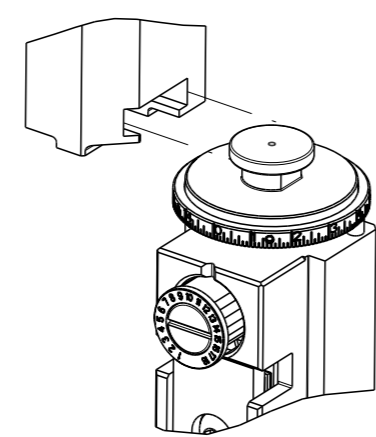

APPLICATOR DATA		
CRIMP	SIZE	TYPE
WIRE	2.19 mm [.086]	F
INSUL	3.94 mm [.155]	O

APPLICATOR INSTRUCTIONS 408-35042

TERMINAL DATA: KOSTAL TERMINAL KOSTAL CRIMP SPECIFICATION	
TERMINAL NAME: SLK 2.8 TAB	
WIRE STRIP LENGTH	TERMINAL INSULATION DIAMETER RANGE
4.00-4.60 mm [.157-.181 IN]	Ø1.90-2.10 mm [.075-.083 IN]
TERMINAL APPLICATION SPECIFICATION	DOC00074173 Rev 06

TERMINALS APPLIED				SEAL INSULATION DIAMETER RANGE
TE TERMINAL	KOSTAL TERMINAL	TE SEAL	KOSTAL SEAL	
2113611-1	10097345	957402-1	1 08 00 44452 2	1.65-2.10
2113611-2	10092199			
2113611-3	10092201			
2113611-4	10097343			

WIRE SIZE	CRIMP HEIGHT mm [INCH]	CRIMP HEIGHT REFERENCE SETTING
1.00mm2	1.35+/-0.03 [.053+/- .001]	9.8
18 AWG	1.30+/-0.03 [.051+/- .001]	10.2

- 1. RECOMMENDED SPARE PARTS
- 2. REFER TO SUPPLIED INSTRUCTION SHEET FOR CLEANING, LUBRICATION AND STORAGE OF APPLICATOR.
- 3. APPLY PART NUMBER 2-23419-6 LOCTITE TO THREADS OF ITEM 242.
- 4. CRIMP HEIGHT REFERENCE SETTING WAS THE SETTING USED WHEN THE APPLICATOR WAS QUALIFIED AT THE FACTORY. ADJUSTMENT MAY BE NECESSARY WHEN RUNNING APPLICATOR IN THE FIELD.
- 5. APPLY TORO-SEAL IN ALLEN SOCKET TO FILL HOLE AFTER FLAT HD HAS BEEN ADJUSTED TO CORRECT HEIGHT AT QUALIFICATION. APPLY #1-23419-5 LOC-TITE TO THREADS.
- 6. UNLESS SPECIFIED OTHERWISE TORQUE VALUES SHALL BE USED PER DOCUMENT, 101-35000.
- 7. THE SETUP SHOWN IS TO RUN SOCKET TERMINAL ONLY. TO RUN PIN TERMINAL, POSITION ITEM 81 BETWEEN ITEMS 7 + 50.

***WARNING**
ON INSTALLATION, SET WIRE DISC TO CRIMP HEIGHT REFERENCE SETTING FOR LARGEST WIRE SIZE. CRIMP HEIGHT REFERENCE SETTINGS GREATER THAN THE VALUE SHOWN MAY CAUSE DAMAGE TO THE CRIMP TOOLING, REFER TO THE INSTRUCTION SHEET FOR PROPER SETUP AND ADJUSTMENTS.

ATLANTIC VERSION
Shown on sheets 1 of 4 & 2 of 4
(Pacific version shown on sheets 3 of 4 & 4 of 4)

LOC	DIST	REVISIONS					
		P	LY#	DESCRIPTION	DATE	OWN	APVD
A	66	C		ECR-15-014425	01OCT2015	MR	TE
		C1		ECR-16-005948	29APR2016	YY	KZ
		D		ECR-18-007347	15MAY2018	KH	LG

-	1	-	1	-	2119640-1	PUSH ROD, AIR FEED	250	
-	1	-	1	-	1803259-1	BUSHING, FLANGED	249	
-	1	-	1	-	2119641-1	FEED CAM, AIR FEED	248	
-	1	1	1	1	2119082-3	CAM, SNAIL, INSULATION ADJUSTMENT	244	
-	1	1	1	1	2079764-1	WASHER, WAVE SPRING, CREST-TO-CREST	243	
-	1	1	1	1	2119083-1	RETAINER, INSULATION DIAL	242	
-	1	1	1	1	7-18023-7	SCR, SKT HD CAP M3 X 4.0	241	
-	-	1	-	1	2119580-1	MECHANICAL FEED ASSEMBLY	239	
-	1	-	1	-	2063440-1	AIR FEED MODULE	238	
-	2	-	2	-	21045-3	RING, RETAIN, EXTERN, 3/16 CRESCENT	172	
-	REF	REF	REF	REF	994970-2	COUNTER, MAGNETIC	164	
-	1	-	1	-	240638-1	SPRING, FEED FINGER	163	
-	1	-	1	-	3-23627-7	PIN, RETAIN, GRVD, 3/16 X .854	137	
-	1	-	1	-	2119799-1	HOLDER, FEED FINGER, AF	136	
-	1	1	1	1	2844908-1	SCREW, LOCKING	99	
-	1	1	1	1	2844907-1	POST, LOCKING	98	
-	1	1	1	1	455888-6	SPACER, CRIMPER	82	
-	1	1	1	1	1-240641-9	SPACER	81	
-	1	1	1	1	1803607-1	DOCUMENTATION PACKAGE	71	
-	1	1	1	1	2119740-1	TAG, IDENTIFICATION	67	
-	2	2	2	2	2168078-1	SCREW, DRIVE, RH, RoHS, 2 x .188	66	
-	1	1	1	1	2168083-2	SCR, SKT HD CAP, RoHS, M4 X 8.0	60	
-	1	1	1	1	5-18022-5	SCR, HEX HD CAP, M4 X 6.0	59	
-	1	1	1	1	985575-3	SCR, FLT SKT HD CAP M3 X 10.0	57	
-	1	1	1	1	1338685-1	PAWL, FEED	56	
-	4	4	4	4	2168083-3	SCR, SKT HD CAP, RoHS, M4 X 12.0	54	
-	2	2	2	2	2168083-8	SCR, SKT HD CAP, RoHS, M4 X 16	53	
-	1	1	1	1	5018030-1	NUT, HEX, REG, RoHS, M3	52	
-	1	1	1	1	811242-5	BUMPER, HOLD DOWN	51	
-	1	1	1	1	690753-2	SPACER, TONKER	50	
-	1	2	1	2	18023-9	SCR, SKT HD CAP M4 X 6.0	49	
-	-	1	-	1	2119652-1	FEED CAM, PRE FEED	48	
-	-	1	-	1	2119653-1	FEED CAM, POST FEED	47	
-	1	1	1	1	1803583-9	APPLICATOR BASIC ASSEMBLY, SF	46	
-	1	1	1	1	1803515-1	RAM ASSEMBLY, SF ATLANTIC	44	
-	1	1	1	1	1803602-1	SCR, BHSC, RoHS (M8 X 25)	41	
-	1	1	1	1	1752356-3	SUPPORT, TERMINAL	34	
-	2	2	2	2	2079383-5	SCR, BHSC, RoHS (M4 X 20)	33	
-	2	2	2	2	3-2844962-2	SPACER, CYLINDRICAL, STRIP GUIDE	30	
-	1	1	1	1	2844992-4	ASSEMBLY, STRIP GUIDE	29	
-	1	1	1	1	455888-3	SPACER, CRIMPER	28	
-	1	1	1	1	240792-1	DRAG, TERMINAL	25	
-	1	1	1	1	1320928-6	STRIP GUIDE	24	
-	1	1	1	1	2168083-2	SCR, SKT HD CAP, RoHS, M4 X 8.0	21	
-	2	2	2	2	1-18028-2	WASHER, FLAT, REG M4	20	
-	1	1	1	1	2119533-1	STRIPPER, SIDE FEED	19	
-	1	1	1	1	2119806-1	INSERT, SHEAR	13	
-	1	1	1	1	3-22280-3	SPRING, COMPRESSION	12	
-	1	1	1	1	1-356885-4	STOP, SHEAR	11	
-	1	1	1	1	2119805-1	SHEAR HOLDER, FRONT	10	
-	1	1	1	1	318707-1	FLOATING SHEAR, FRONT	9	
-	1	2	2	1	1	3-1803055-0	ANVIL, COMBINATION	8
-	1	1	1	1	1	1-240641-4	SPACER	7
-	-	-	-	-	-	-	6	
-	1	1	1	1	2119781-1	DEPRESSOR, SHEAR	5	
-	1	1	1	1	238011-4	BLOCK, CRIMPER SPACER	4	
-	1	2	2	1	1	2-2119784-9	CRIMPER, INSULATION O PREMIUM	3
-	1	2	1	1	1	1-455888-1	SPACER, CRIMPER	2
-	1	2	2	1	1	5-1490019-3	CRIMPER, WIRE PREMIUM	1

DIMENSIONS:		TOLERANCES UNLESS OTHERWISE SPECIFIED:		MATERIAL:	
mm	PLC	mm	PLC		FINISH
0	PLC	±			
1	PLC	±			
2	PLC	±			
3	PLC	±			
4	PLC	±			
5	PLC	±			
6	PLC	±			
7	PLC	±			
8	PLC	±			
9	PLC	±			
10	PLC	±			
11	PLC	±			
12	PLC	±			
13	PLC	±			
14	PLC	±			
15	PLC	±			
16	PLC	±			
17	PLC	±			
18	PLC	±			
19	PLC	±			
20	PLC	±			
21	PLC	±			
22	PLC	±			
23	PLC	±			
24	PLC	±			
25	PLC	±			
26	PLC	±			
27	PLC	±			
28	PLC	±			
29	PLC	±			
30	PLC	±			
31	PLC	±			
32	PLC	±			
33	PLC	±			
34	PLC	±			
35	PLC	±			
36	PLC	±			
37	PLC	±			
38	PLC	±			
39	PLC	±			
40	PLC	±			
41	PLC	±			
42	PLC	±			
43	PLC	±			
44	PLC	±			
45	PLC	±			
46	PLC	±			
47	PLC	±			
48	PLC	±			
49	PLC	±			
50	PLC	±			
51	PLC	±			
52	PLC	±			
53	PLC	±			
54	PLC	±			
55	PLC	±			
56	PLC	±			
57	PLC	±			
58	PLC	±			
59	PLC	±			
60	PLC	±			
61	PLC	±			
62	PLC	±			
63	PLC	±			
64	PLC	±			
65	PLC	±			
66	PLC	±			
67	PLC	±			
68	PLC	±			
69	PLC	±			
70	PLC	±			
71	PLC	±			
72	PLC	±			
73	PLC	±			
74	PLC	±			
75	PLC	±			
76	PLC	±			
77	PLC	±			
78	PLC	±			
79	PLC	±			
80	PLC	±			
81	PLC	±			
82	PLC	±			
83	PLC	±			
84	PLC	±			
85	PLC	±			
86	PLC	±			
87	PLC	±			
88	PLC	±			
89	PLC	±			
90	PLC	±			
91	PLC	±			
92	PLC	±			
93	PLC	±			
94	PLC	±			
95	PLC	±			
96	PLC	±			
97	PLC	±			
98	PLC	±			
99	PLC	±			
100	PLC	±			

LOC	DIST	REVISIONS				
A	66	REV	DESCRIPTION	DATE	OWN	APVD
		-	SEE SHEET 1	-	-	-

FEED TYPE MECHANICAL

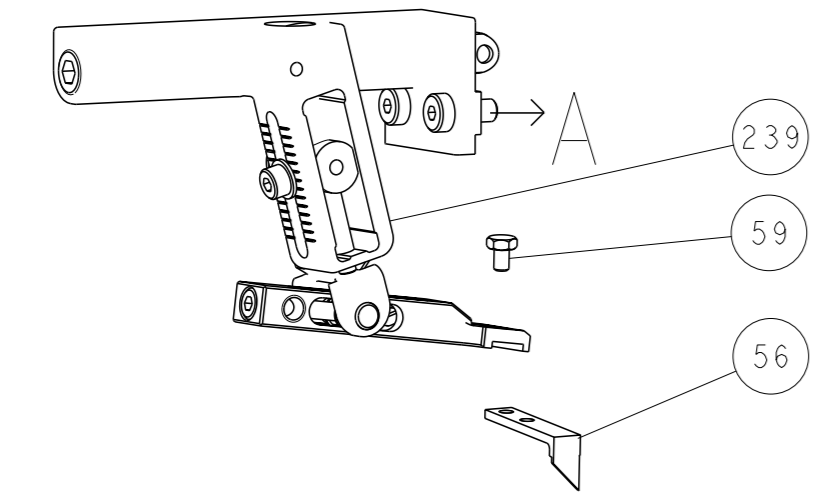

PNEUMATIC

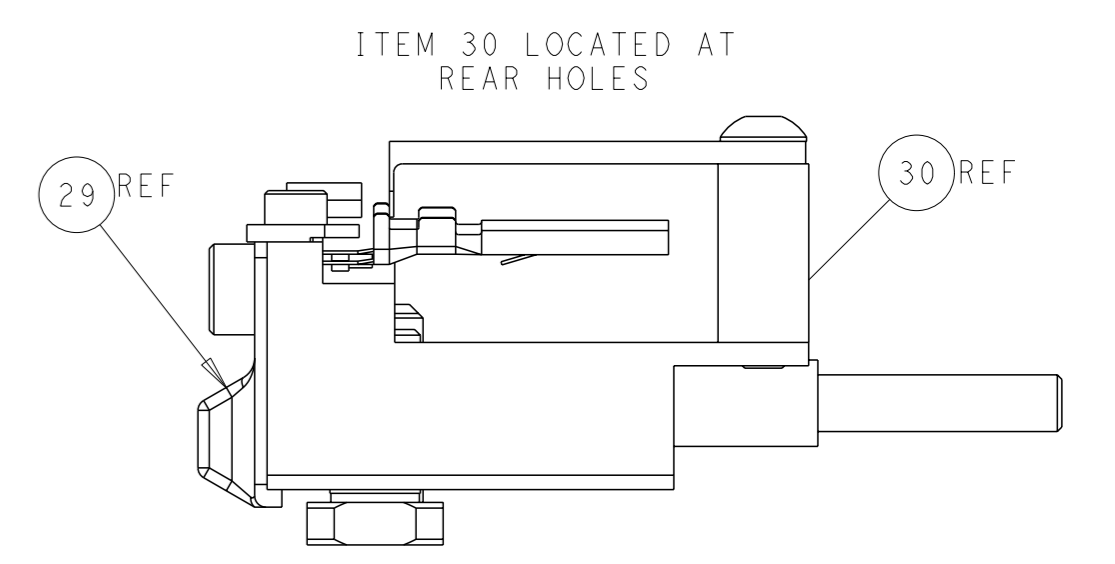
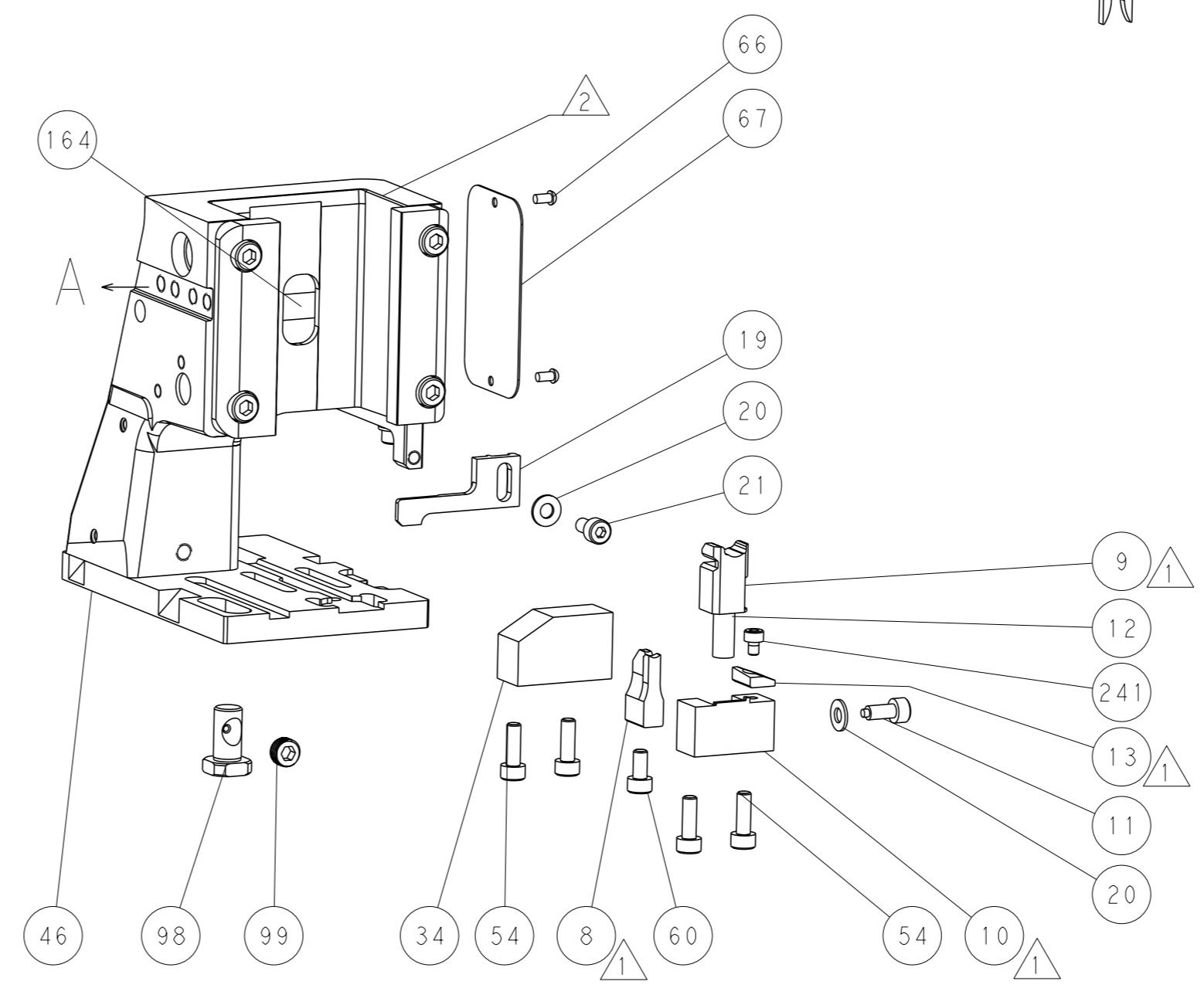
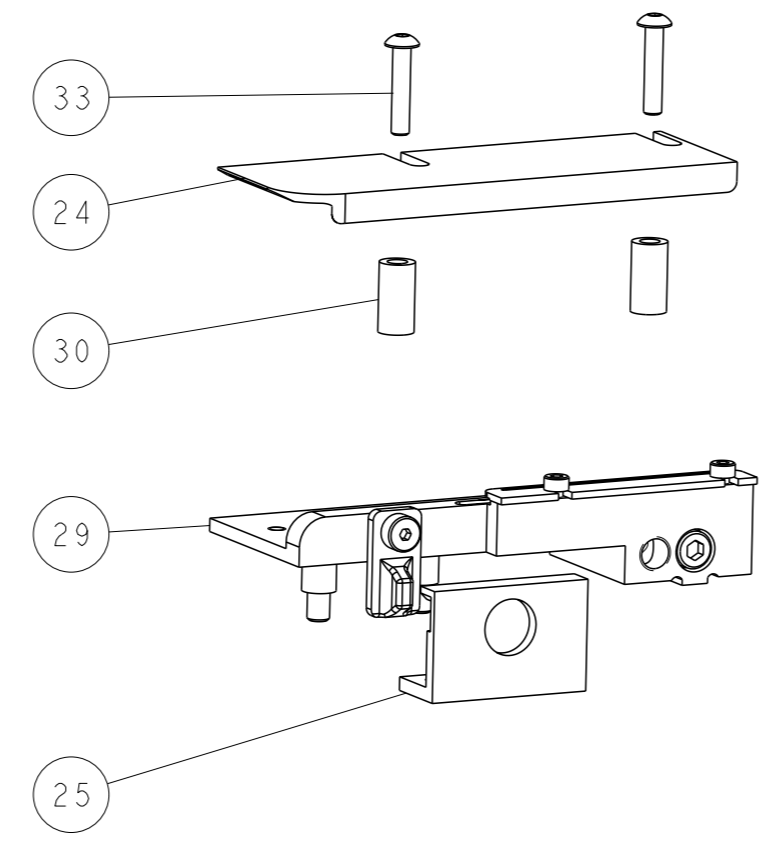
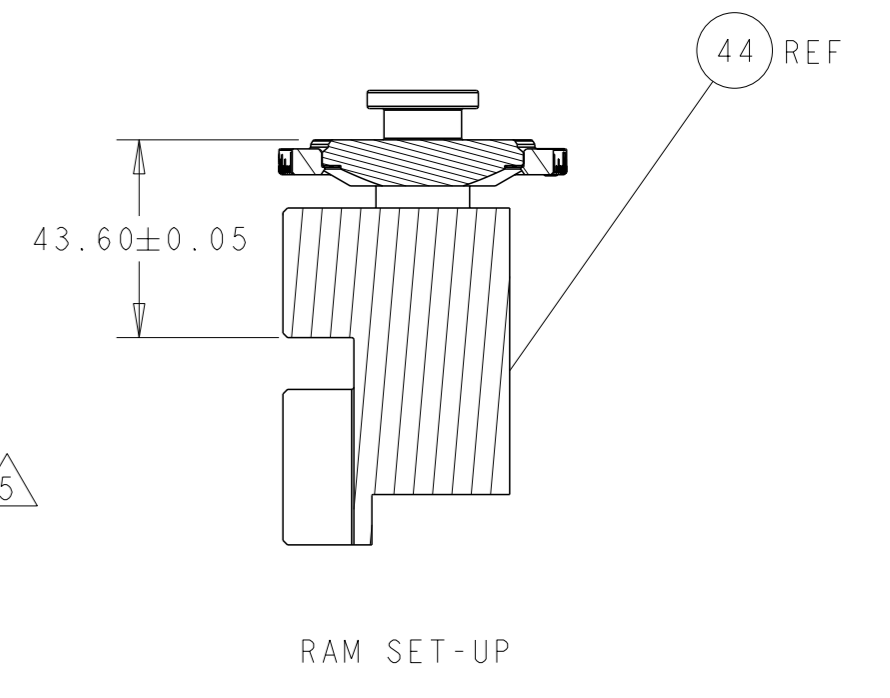
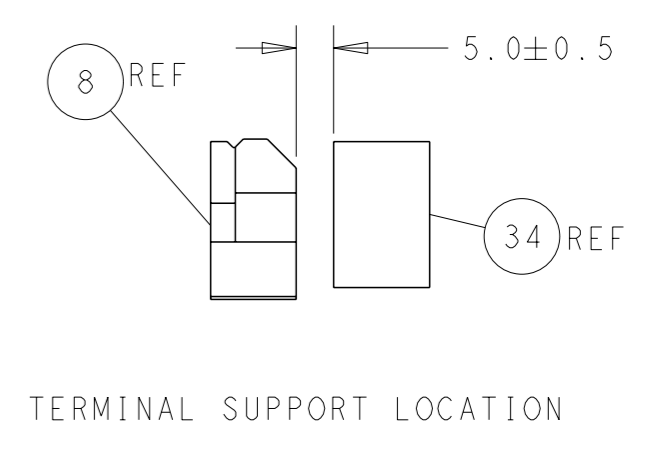
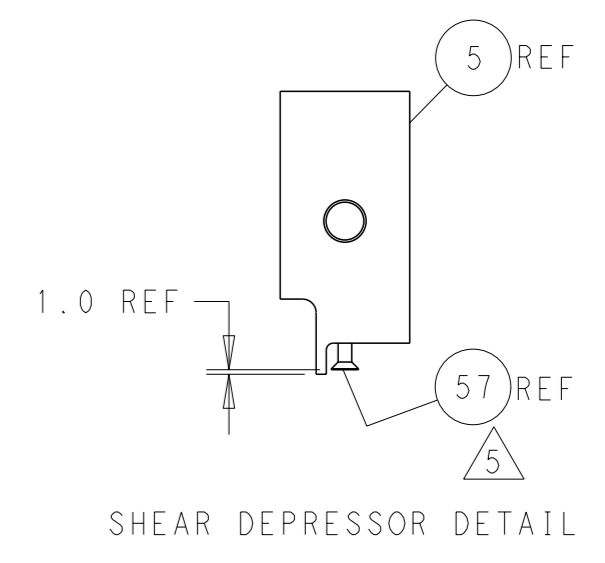
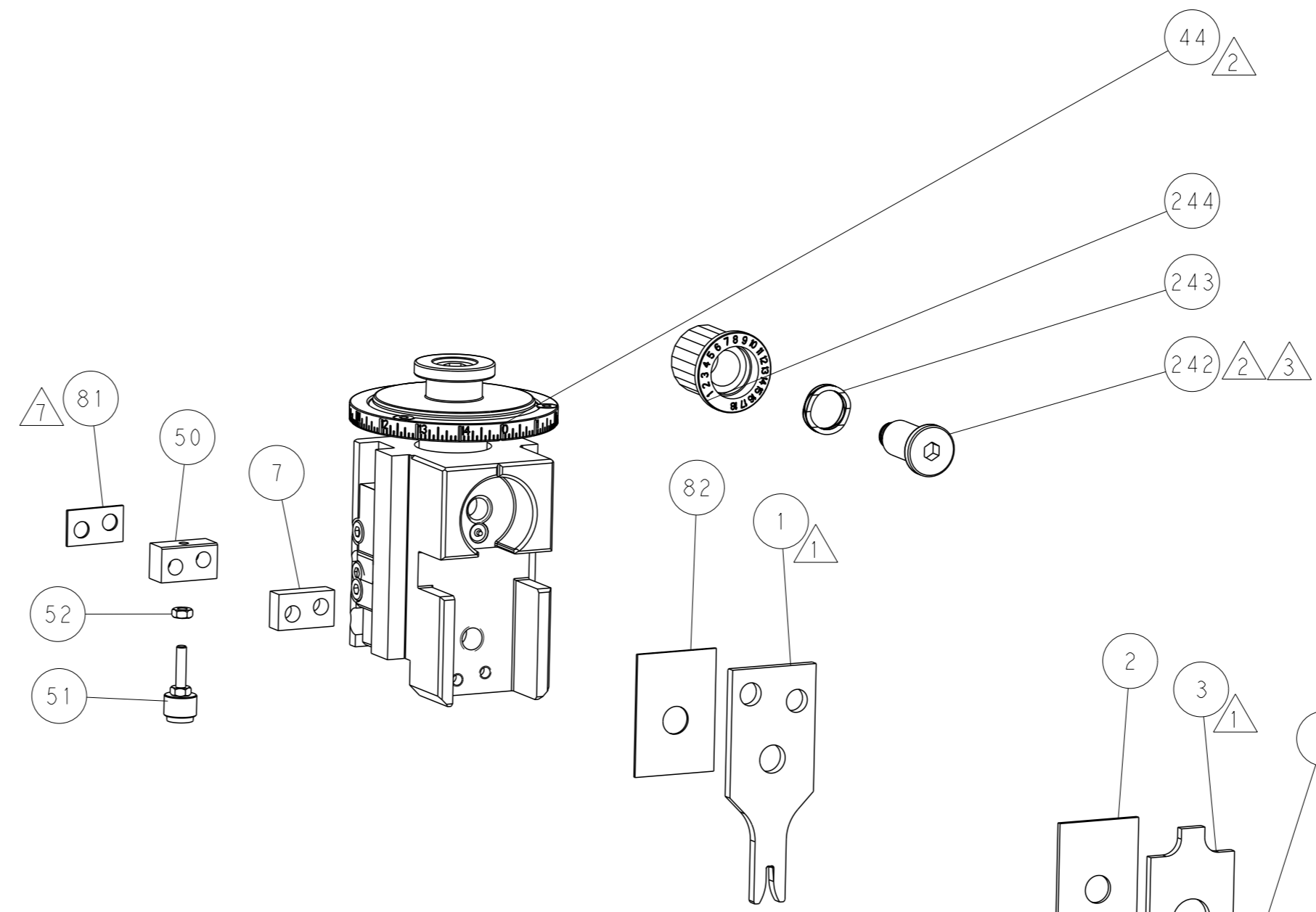
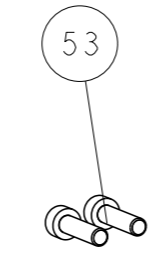
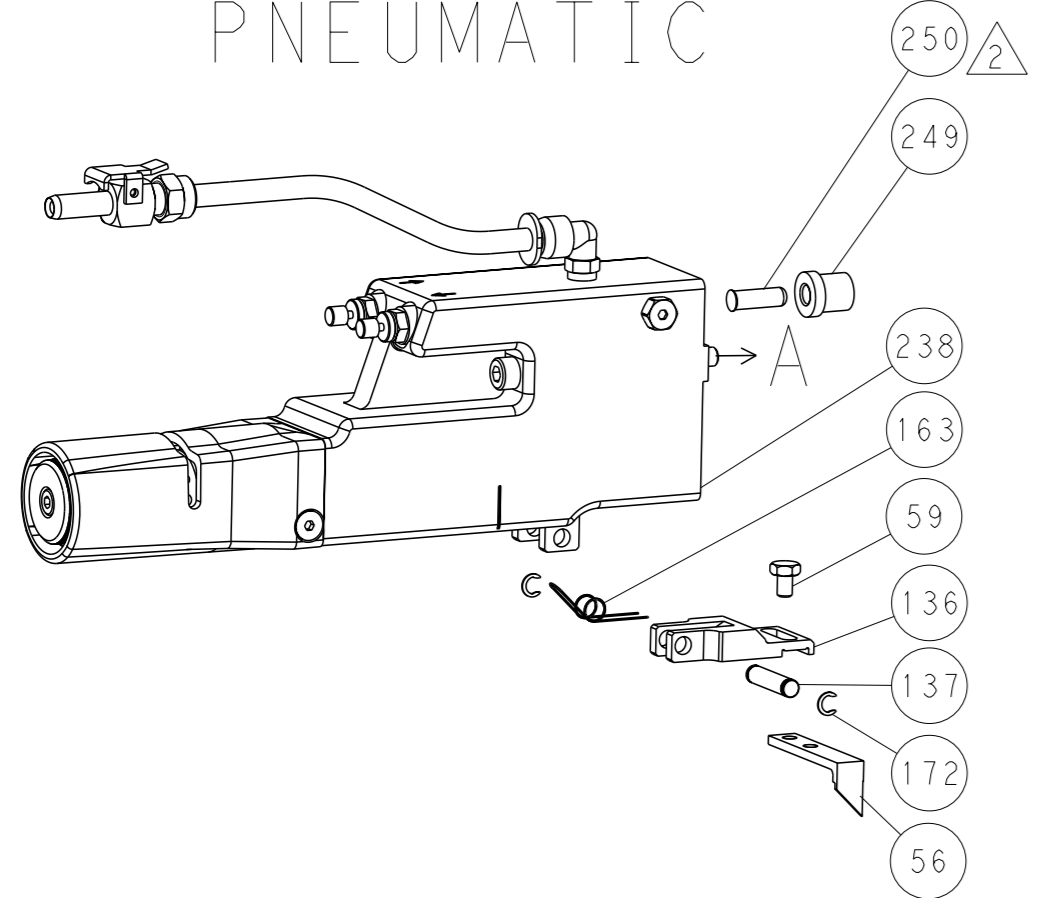

CAM POSITIONS

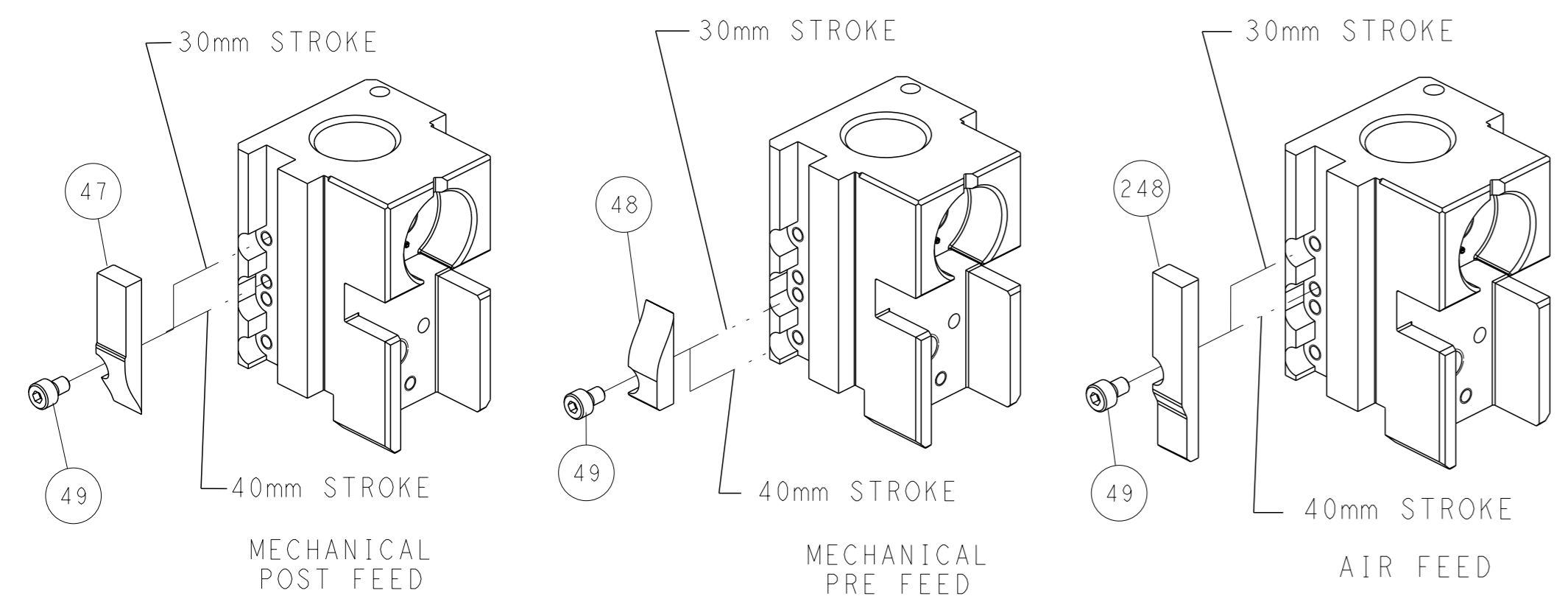

ATLANTIC VERSION
 Shown on sheets 1 of 4 & 2 of 4
 (Pacific version shown on sheets 3 of 4 & 4 of 4)

DIMENSIONS: mm 		TOLERANCES UNLESS OTHERWISE SPECIFIED: 0 PLC ± 1 PLC ± 2 PLC ± 3 PLC ± 4 PLC ± ANGLES ±		DWN R. HUANG 07NOV2014 CHK L. ZHANAG 07NOV2014 APVD U. GUO 07NOV2014 PRODUCT SPEC APPLICATION SPEC WEIGHT MATERIAL		NAME Ocean Side Feed Applicator SIZE A1 CAGE CODE 00779 DRAWING NO. C=2266565 SCALE 1:2 SHEET 2 of 4 REV D		TE Connectivity Harrisburg, PA 17105-3608 RESTRICTED TO	
-----------------------	--	---	--	--	--	--	--	---	--

THIS DRAWING IS UNPUBLISHED.	RELEASED FOR PUBLICATION	20	
COPYRIGHT 20 BY TYCO ELECTRONICS CORPORATION. ALL RIGHTS RESERVED.			
PART NUMBER	REVISION	DESCRIPTION	FEED TYPE
2-2266565-1	D	FINE CRIMP HEIGHT ADJUST	MECHANICAL
2-2266565-2	D	FINE CRIMP HEIGHT ADJUST	PNEUMATIC
7-2266565-7	B	CRIMP TOOLING KIT	-

PACIFIC VERSION TERMINATOR INTERFACE ADAPTER

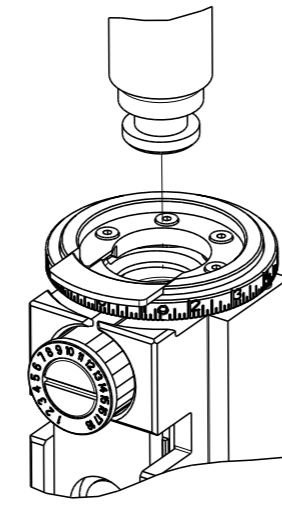

APPLICATOR DATA		
CRIMP	SIZE	TYPE
WIRE	2.19 mm [.086]	F
INSUL	3.94 mm [.155]	O
APPLICATOR INSTRUCTIONS 408-35042		

TERMINAL DATA: KOSTAL TERMINAL		KOSTAL CRIMP SPECIFICATION	
TERMINAL NAME: SLK 2.8 TAB			
WIRE STRIP LENGTH		TERMINAL INSULATION DIAMETER RANGE	
4.00-4.60 mm [.157-.181 IN]		Ø1.90-2.10 mm [.075-.083 IN]	
TERMINAL APPLICATION SPECIFICATION DOC00074173 Rev 06			

TERMINALS APPLIED				SEAL INSULATION DIAMETER RANGE
TE TERMINAL	KOSTAL TERMINAL	TE SEAL	KOSTAL SEAL	
2113611-1	10097345	957402-1	1 08 00 44452 2	1.65-2.10
2113611-2	10092199			
2113611-3	10092201			
2113611-4	10097343			

WIRE SIZE	CRIMP HEIGHT mm [INCH]	CRIMP HEIGHT REFERENCE SETTING
1.00mm2	1.35+/-0.03 [.053+/-0.001]	9.8
18 AWG	1.30+/-0.03 [.051+/-0.001]	10.2

- 1. RECOMMENDED SPARE PARTS
- 2. REFER TO SUPPLIED INSTRUCTION SHEET FOR CLEANING, LUBRICATION AND STORAGE OF APPLICATOR.
- 3. APPLY PART NUMBER 2-23419-6 LOCTITE TO THREADS OF ITEM 242.
- 4. CRIMP HEIGHT REFERENCE SETTING WAS THE SETTING USED WHEN THE APPLICATOR WAS QUALIFIED AT THE FACTORY. ADJUSTMENT MAY BE NECESSARY WHEN RUNNING APPLICATOR IN THE FIELD.
- 5. APPLY TORQ-SEAL IN ALLEN SOCKET TO FILL HOLE AFTER FLAT HD HAS BEEN ADJUSTED TO CORRECT HEIGHT AT QUALIFICATION. APPLY #1-23419-5 LOC-TITE TO THREADS.
- 6. UNLESS SPECIFIED OTHERWISE TORQUE VALUES SHALL BE USED PER DOCUMENT, 101-35000.
- 7. THE SETUP SHOWN IS TO RUN SOCKET TERMINAL ONLY. TO RUN PIN TERMINAL, POSITION ITEM 81 BETWEEN ITEMS 7 + 50.

***WARNING**
 ON INSTALLATION, SET WIRE DISC TO CRIMP HEIGHT REFERENCE SETTING FOR LARGEST WIRE SIZE. CRIMP HEIGHT REFERENCE SETTINGS GREATER THAN THE VALUE SHOWN MAY CAUSE DAMAGE TO THE CRIMP TOOLING, REFER TO THE INSTRUCTION SHEET FOR PROPER SETUP AND ADJUSTMENTS.

PACIFIC VERSION
 Shown on sheets 3 of 4 & 4 of 4
 (Atlantic version shown on sheets 1 of 4 & 2 of 4)

LOC	DIST	REVISIONS					
A	66	P	LYR	DESCRIPTION	DATE	OWN	APVD
		-	-	SEE SHEET 1	-	-	-

-	1	-	2119640-1	PUSH ROD, AIR FEED	250
-	1	-	1803259-1	BUSHING, FLANGED	249
-	1	1	2119082-3	CAM, SNAIL, INSULATION ADJUSTMENT	244
-	1	1	2079764-1	WASHER, WAVE SPRING, CREST-TO-CREST	243
-	1	1	2119083-1	RETAINER, INSULATION DIAL	242
-	1	1	7-18023-7	SCR, SKT HD CAP M3 X 4.0	241
-	-	1	2119580-1	MECHANICAL FEED ASSEMBLY	239
-	1	-	2063440-1	AIR FEED MODULE	238
-	2	-	21045-3	RING, RETAIN, EXTERN, 3/16 CRESCENT	172
-	REF	REF	994970-2	COUNTER, MAGNETIC	164
-	1	-	240638-1	SPRING, FEED FINGER	163
-	1	-	2119641-2	FEED CAM, AIR FEED	151
-	1	1	2168083-8	SCR, SKT HD CAP, RoHS, M4 X 16	144
-	4	4	2168083-9	SCR, SKT HD CAP, RoHS, M4 X 20	143
-	-	1	2119653-2	FEED CAM, POST FEED	142
-	1	1	1-1803583-0	APPLICATOR BASIC ASSEMBLY, SF	141
-	1	1	1803516-1	RAM ASSEMBLY, SF PACIFIC	140
-	1	-	3-23627-7	PIN, RETAIN, GRVD, 3/16 X .854	137
-	1	-	2119799-1	HOLDER, FEED FINGER, AF	136
-	1	1	2844908-1	SCREW, LOCKING	99
-	1	1	2844907-1	POST, LOCKING	98
-	1	1	455888-6	SPACER, CRIMPER	82
-	1	1	1-240641-9	SPACER	81
-	1	1	1803607-1	DOCUMENTATION PACKAGE	71
-	1	1	2119740-1	TAG, IDENTIFICATION	67
-	2	2	2168078-1	SCREW, DRIVE, RH, RoHS, 2 x .188	66
-	1	1	5-18022-5	SCR, HEX HD CAP, M4 X 6.0	59
-	1	1	985575-3	SCR, FLT SKT HD CAP M3 X 10.0	57
-	1	1	1338685-1	PAWL, FEED	56
-	2	2	2168083-8	SCR, SKT HD CAP, RoHS, M4 X 16	53
-	1	1	5018030-1	NUT, HEX, REG, RoHS, M3	52
-	1	1	811242-5	BUMPER, HOLD DOWN	51
-	1	1	690753-2	SPACER, TONKER	50
-	1	2	18023-9	SCR, SKT HD CAP M4 X 6.0	49
-	-	1	2119652-1	FEED CAM, PRE FEED	48
-	1	1	1803602-1	SCR, BHSC, RoHS (M8 X 25)	41
-	1	1	1752356-3	SUPPORT, TERMINAL	34
-	2	2	2079383-5	SCR, BHSC, RoHS (M4 X 20)	33
-	2	2	3-2844962-2	SPACER, CYLINDRICAL, STRIP GUIDE	30
-	1	1	2844992-4	ASSEMBLY, STRIP GUIDE	29
-	1	1	455888-3	SPACER, CRIMPER	28
-	1	1	240792-1	DRAG, TERMINAL	25
-	1	1	1320928-6	STRIP GUIDE	24
-	1	1	2168083-2	SCR, SKT HD CAP, RoHS, M4 X 8.0	21
-	2	2	1-18028-2	WASHER, FLAT, REG M4	20
-	1	1	2119533-1	STRIPPER, SIDE FEED	19
-	1	1	2119806-1	INSERT, SHEAR	13
-	1	1	3-22280-3	SPRING, COMPRESSION	12
-	1	1	1-356885-4	STOP, SHEAR	11
-	1	1	2119805-1	SHEAR HOLDER, FRONT	10
-	1	1	318707-1	FLOATING SHEAR, FRONT	9
1	1	1	3-1803055-0	ANVIL, COMBINATION	8
-	1	1	1-240641-4	SPACER	7
-	-	-	-	-	6
-	1	1	2119781-1	DEPRESSOR, SHEAR	5
-	1	1	238011-4	BLOCK, CRIMPER SPACER	4
1	1	1	2-2119784-9	CRIMPER, INSULATION O PREMIUM	3
-	1	1	1-455888-1	SPACER, CRIMPER	2
1	1	1	5-1490019-3	CRIMPER, WIRE PREMIUM	1

<small>THE DRAWING IS CONTROLLED DOCUMENT FROM THE REGISTERED ORGANIZATION. IT IS SUBJECT TO CHANGE AND THE USER MUST CONTACT THE REGISTERED ORGANIZATION SHOULD BE CONTACTED FOR THE LATEST REVISION.</small>		OWN: H. HUANG 07NOV2014 CHK: L. ZHANAG 07NOV2014 APVD: J. GUO 07NOV2014	STE TE Connectivity Harrisburg, PA 17105-3608
DIMENSIONS: mm 0 PLC ± 1 PLC ± 2 PLC ± 3 PLC ± 4 PLC ± ANGLES FINISH ±		TOLERANCES UNLESS OTHERWISE SPECIFIED: ± ± ± ± ±	NAME: Ocean Side Feed Applicator SIZE: A1 CAGE CODE: 00779 DRAWING NO: 2266565 RESTRICTED TO:
MATERIAL:		WEIGHT:	SCALE: 1:2 SHEET 3 OF 4 REV D

LOC	DIST	REVISIONS			
A	66	REV	DATE	OWN	APVD
-	-	SEE SHEET 1	-	-	-

FEED TYPE MECHANICAL

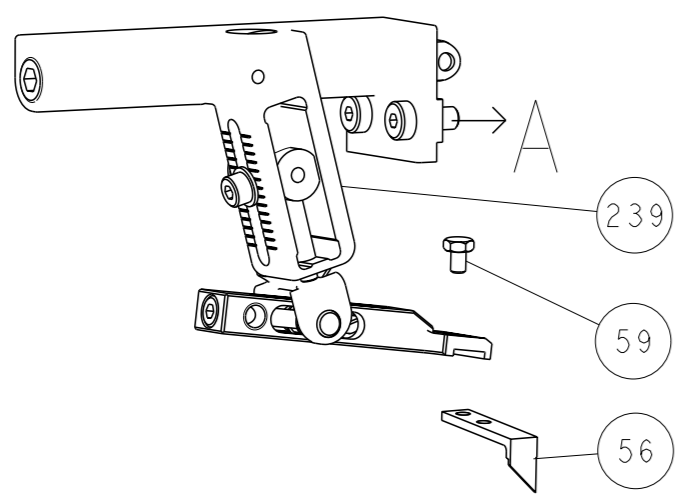

PNEUMATIC

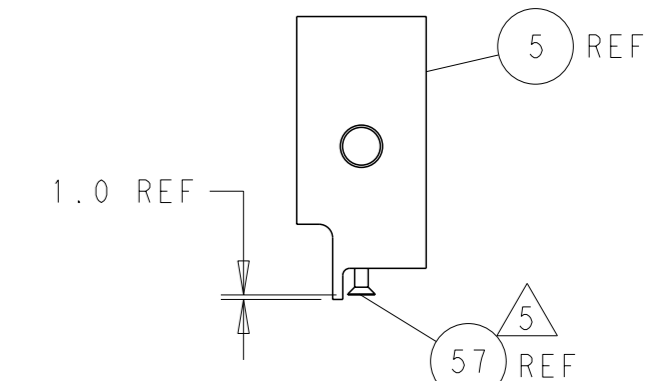
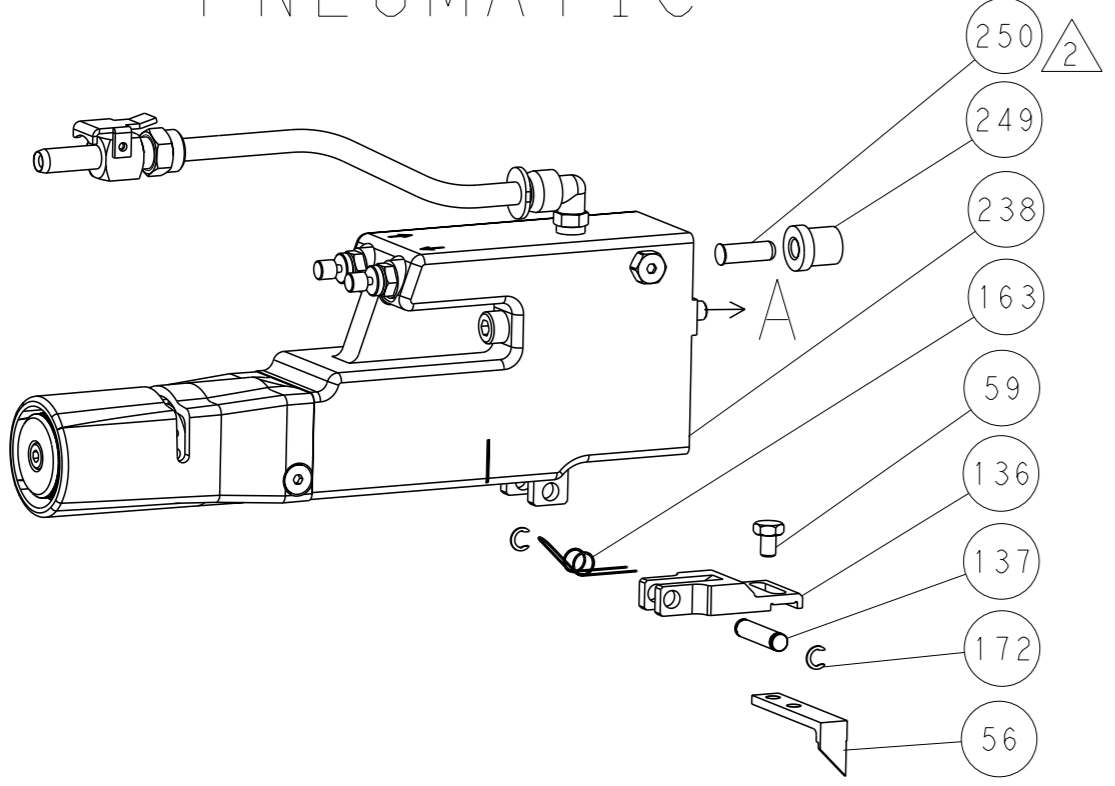

SHEAR DEPRESSOR DETAIL

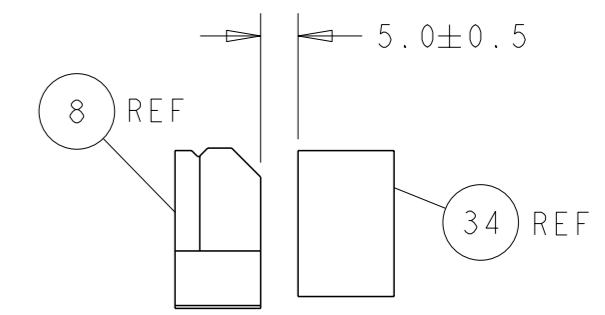

TERMINAL SUPPORT LOCATION

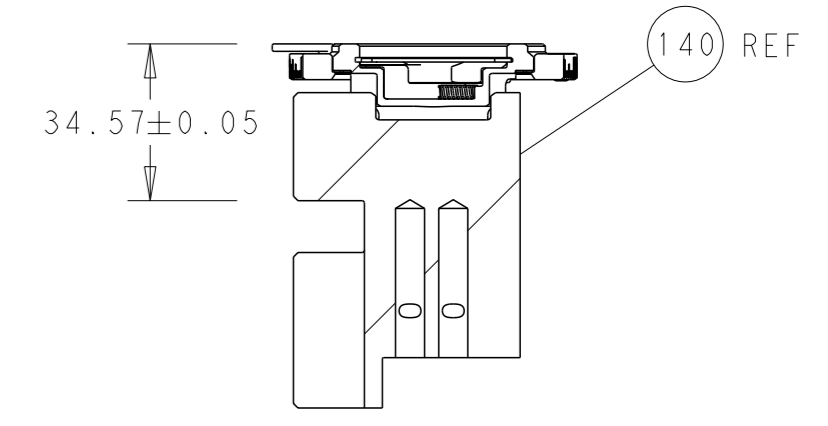

RAM SET-UP

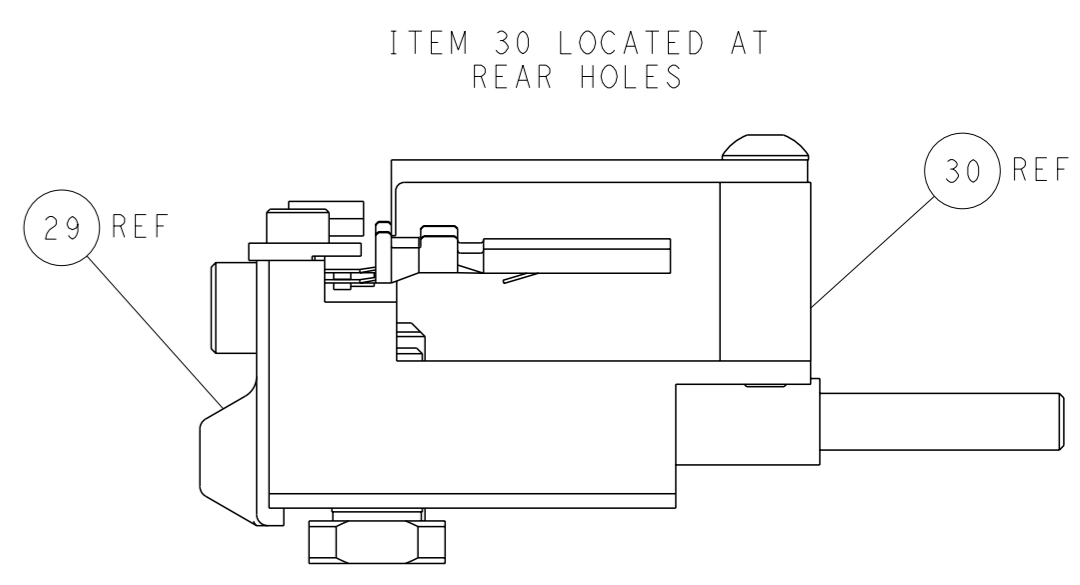

FEED TRACK POSITION GUIDE BY INSULATION BARREL

CAM POSITIONS

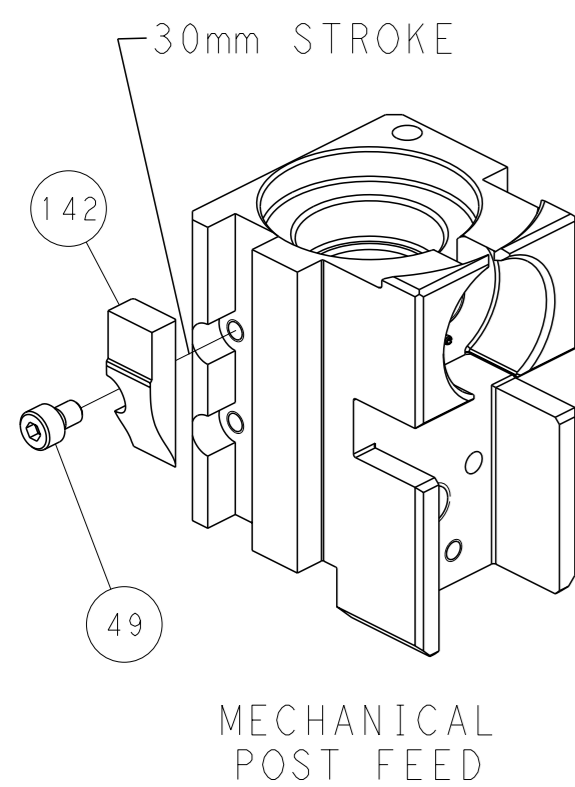

MECHANICAL POST FEED

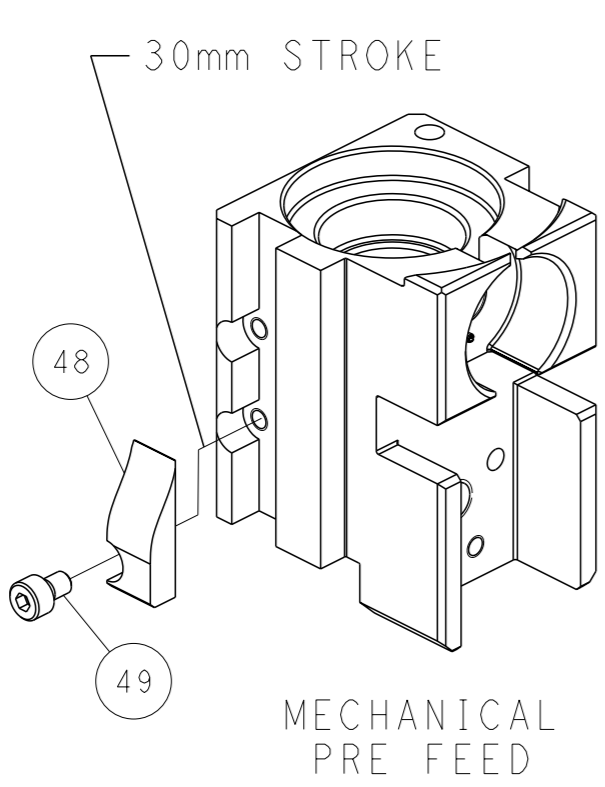

MECHANICAL PRE FEED

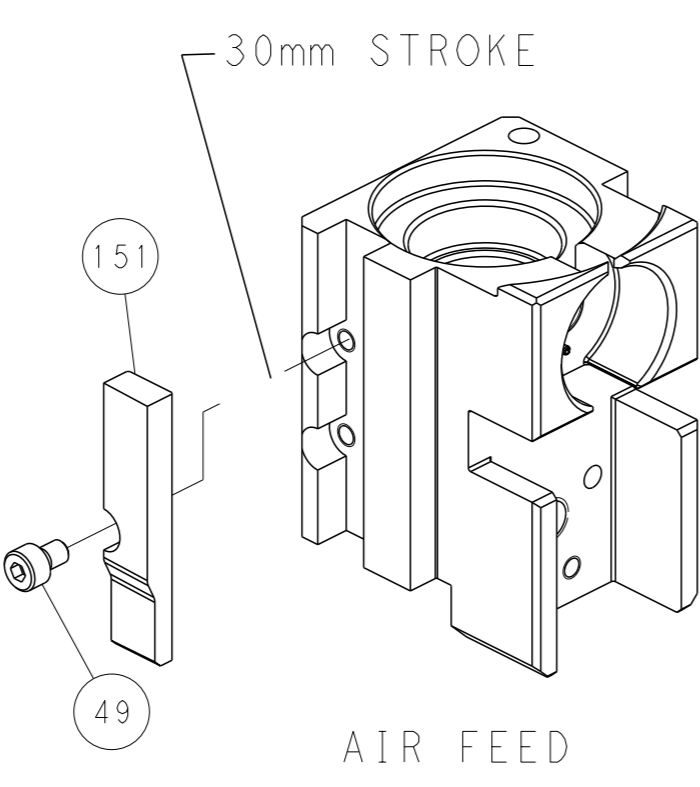

AIR FEED

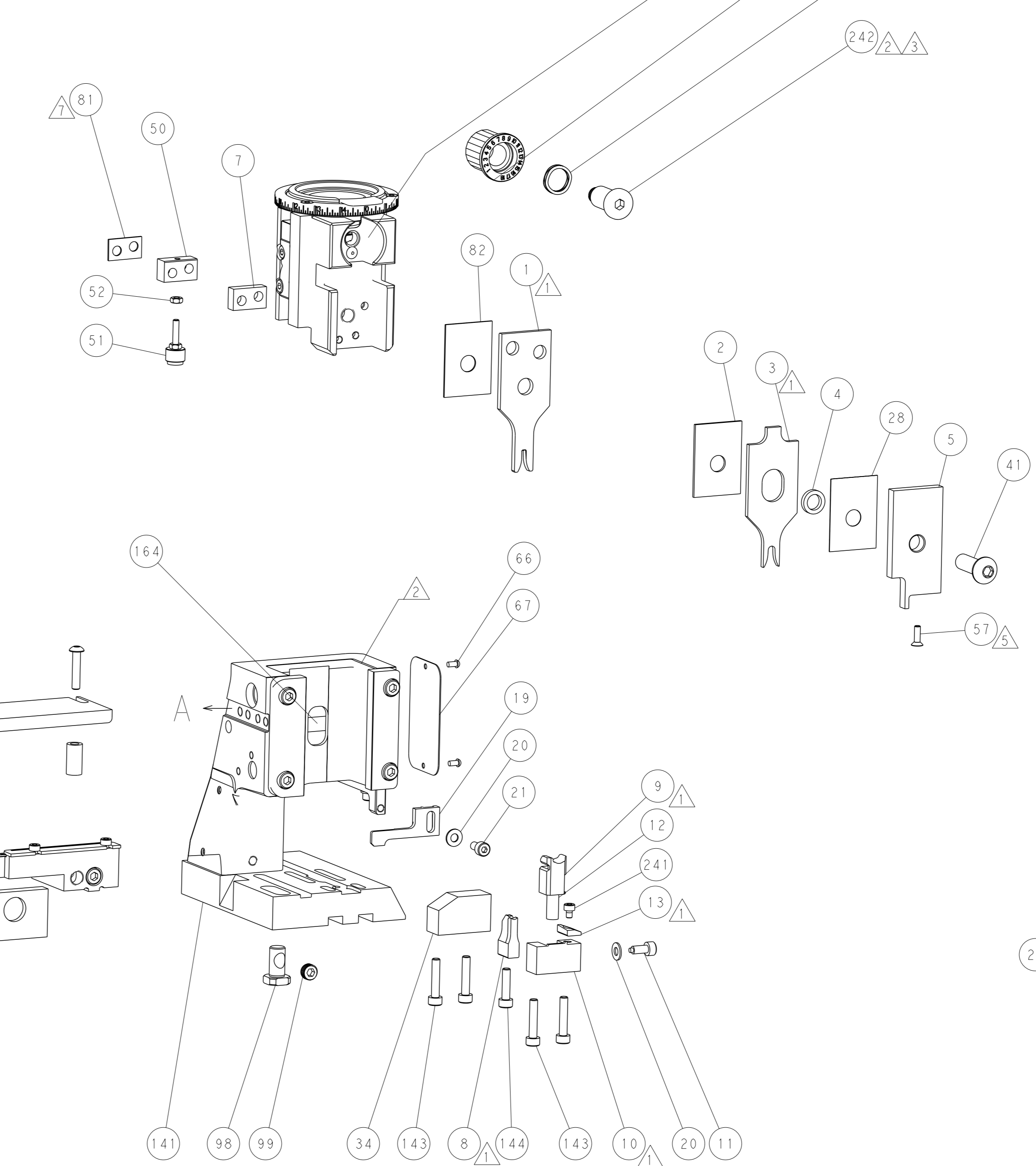

PACIFIC VERSION
 Shown on sheets 3 of 4 & 4 of 4
 (Atlantic version shown on sheets 1 of 4 & 2 of 4)

<small>THIS DRAWING IS A CONTROLLED DOCUMENT FOR TYCO ELECTRONICS CORPORATION. IT IS SUBJECT TO CHANGE AND THE CONTROLLER'S ENGINEERING ORGANIZATION SHOULD BE CONTACTED FOR THE LATEST REVISION.</small>		OWN: H. HUANG 07NOV2014 CHK: L. ZHANAG 07NOV2014 APVD: J. GUO 07NOV2014	TE Connectivity Harrisburg, PA 17105-3608
DIMENSIONS: mm TOLERANCES UNLESS OTHERWISE SPECIFIED: 0 PLC ± 1 PLC ± 2 PLC ± 3 PLC ± 4 PLC ± ANGLES FINISH ±		NAME: Ocean Side Feed Applicator SIZE: A1 CAGE CODE: 00779 DRAWING NO: 2266565	RESTRICTED TO: - SCALE: 1:2 SHEET: 4 of 4 REV: D
MATERIAL: - FINISH: -		WEIGHT: - Customer Accessible Production Drawing	SHEETS 1 & 2 ARE NOT REQUIRED FOR PACIFIC VERSION