

ATLANTIC VERSION TERMINATOR INTERFACE ADAPTER	PART NUMBER	REVISION	DESCRIPTION	FEED TYPE
	2266112-1	B	FINE CRIMP HEIGHT ADJUST	MECHANICAL
	2266112-2	B	FINE CRIMP HEIGHT ADJUST	PNEUMATIC
	2266112-5	B	FINE CRIMP HEIGHT ADJUST	SERVO LATCH PLATE
	2266112-6	B	NON-CRIMP HEIGHT ADJUST	SERVO LATCH PLATE
	2266112-7	B	FINE CRIMP HEIGHT ADJUST	NONE
	7-2266112-7	B	CRIMP TOOLING KIT	
	7-2266112-8	B	APPLICATOR CONVERSION KIT	

APPLICATOR STYLE CONVERSION CHART									
CONVERT TO	PART NUMBERS REQUIRED								
PNEUMATIC FEED	2119950-1	1338683-8	5-18022-5	2119641-1	2119799-1	2063440-1			
SERVO LATCH PLATE	2119951-1	-	8-2266112-5	1901094-3	-	2168400-6 (QUANTITY 2)			
SMART APPLICATOR	2161326-1	-	8-2266112-4	-	-	-			
MECHANICAL FEED	2119949-1	1338683-8	5-18022-5	2119653-1	-	-			
SERVO LATCH PLATE	2119951-1	-	8-2266112-5	1901094-3	-	2168400-6 (QUANTITY 2)			
SMART APPLICATOR	2161326-1	-	8-2266112-4	-	-	-			
MECHANICAL FEED	2119949-1	1338683-8	5-18022-5	2119653-1	-	-			
PNEUMATIC FEED	2119950-1	1338683-8	5-18022-5	2119641-1	2119799-1	2063440-1			

APPLICATOR DATA		
CRIMP	SIZE	TYPE
WIRE	2.62 mm [.103]	F
INSUL	3.20 mm [.126]	O

APPLICATOR INSTRUCTIONS
408-10389

APPLICATOR CONVERSION KITS	
PART NUMBER	INSULATION DIAMETER RANGE
7-2266112-8	Ø 3.15-3.56mm [.124-.140]
7-2266113-8	Ø 2.72-3.12mm [.107-.123]
7-2266114-8	Ø 2.29-2.69mm [.090-.106]
7-2266115-8	Ø 1.91-2.26mm [.075-.089]

TERMINAL DATA: DEUTSCH TERMINAL DEUTSCH CRIMP SPECIFICATION			
TERMINAL NAME: STAMPED CONTACT PIN SIZE 16			
WIRE STRIP LENGTH	INSULATION DIAMETER RANGE		
4.44-5.72 mm [.175-.225 IN]	Ø 3.15-3.56 mm [.124-.140 IN]		
TERMINAL APPLICATION SPECIFICATION 0425-039-0000 Rev E			
TERMINALS APPLIED			
TE TERMINAL	DEUTSCH TERMINAL	TE TERMINAL	DEUTSCH TERMINAL
2113238-1	1060-16-1222	2113238-2	1060-16-1244
2113238-3	1060-16-1277		

TERMINAL DATA: DEUTSCH TERMINAL DEUTSCH CRIMP SPECIFICATION			
TERMINAL NAME: STAMPED CONTACT SOCKET SIZE 16			
WIRE STRIP LENGTH	INSULATION DIAMETER RANGE		
4.44-5.72 mm [.175-.225 IN]	Ø 3.15-3.56 mm [.124-.140 IN]		
TERMINAL APPLICATION SPECIFICATION 0425-039-0000 Rev E			
TERMINALS APPLIED			
TE TERMINAL	DEUTSCH TERMINAL	TE TERMINAL	DEUTSCH TERMINAL
1949119-1	1062-16-1222	1949119-2	1062-16-1244
1949119-3	1062-16-1277	1949119-4	1062-16-1422
1949119-5	1062-16-1444	1949119-6	1062-16-1477

WIRE SIZE	CRIMP HEIGHT mm [INCH]	CRIMP HEIGHT REFERENCE SETTING
12 AWG	1.78+0.03/-0.05 [.070+.001/- .002]	5.6
2.50mm2	1.73+0.03/-0.05 [.068+.001/- .002]	6.1
14 AWG	1.65+0.03/-0.05 [.065+.001/- .002]	6.7
2.00mm2	1.63+0.03/-0.05 [.064+.001/- .002]	6.9
1.50mm2	1.50+0.03/-0.05 [.059+.001/- .002]	8.2
16 AWG	1.47+0.03/-0.05 [.058+.001/- .002]	8.5
1.00mm2	1.40+0.03/-0.05 [.055+.001/- .002]	9.3

- RECOMMENDED SPARE PARTS
- GREASE BEARING SURFACES LIGHTLY
- LUBRICATE DAILY PER THE APPLICATOR INSTRUCTION SHEET SUPPLIED WITH THE APPLICATOR.
- APPLICATOR SPECIFIC DATA TO BE ENTERED INTO BLANK MEMORY CHIP AT ASSEMBLY. SEE BELOW FOR PART NUMBER:
 MECHANICAL FEED WITH "SMART APPLICATOR" CONVERSION: 8-2266112-4
 PNEUMATIC FEED WITH "SMART APPLICATOR" CONVERSION: 8-2266112-4
 SERVO FEED WITH "FINE CRIMP HEIGHT ADJUST": 8-2266112-5
 SERVO FEED WITH "NON-CRIMP HEIGHT ADJUST": 8-2266112-6
- ADJUSTMENT OF THE STRIPPER MAY BE REQUIRED WHEN MOVING THE APPLICATOR BETWEEN BENCH AND LEADMAKER APPLICATIONS.
- APPLY PART NUMBER 1-23419-5 LOCTITE TO THREADS OF ITEMS 62. APPLY PART NUMBER 2-23419-6 LOCTITE TO THREADS OF ITEMS 242. FOR -6 ONLY APPLY PART NUMBER 1-23419-5 LOCTITE TO THREADS OF ITEM 37.
- GREASE THREADS, GROOVE AND O-RING ON ITEMS 35 & 252.
- MAGNET, ITEM 166 MUST BE ORIENTED CORRECTLY IN ORDER TO PROPERLY ACTUATE THE COUNTER.
- CRIMP HEIGHT REFERENCE SETTING WAS THE SETTING USED WHEN THE APPLICATOR WAS QUALIFIED AT THE FACTORY. ADJUSTMENT MAY BE NECESSARY WHEN RUNNING APPLICATOR IN THE FIELD.
- SPARE FEED CAM STORAGE LOCATION REFER TO INSTRUCTION SHEET FOR ADDITIONAL INFORMATION.
- TO CONVERT THE APPLICATOR TO A NON-CARRIER CUTTING STYLE, REMOVE ITEM 13 AND ATTACH TO THE LOCATION ON THE BACK SIDE OF THE HOUSING. REFER TO INSTRUCTION SHEET FOR ADDITIONAL INFORMATION.
- WHEN ASSEMBLING A NON CRIMP HEIGHT ADJUST APPLICATOR (-6) USE SHIMS FROM ITEM 260 TO ACHIEVE A NOMINAL SHIM HEIGHT OF 4.02.
- SEE APPROPRIATE APPLICATOR LOG SHEETS FOR APPLIED TERMINALS, WIRE RANGE AND MEMORY CHIP.
- TERMINAL LUBRICANT IS RECOMMENDED.

***WARNING**
 ON INSTALLATION, SET WIRE DISC, ITEM 40 TO LARGEST WIRE SIZE SETTING. USE OF SETTINGS BELOW MINIMUM REQUIRED CRIMP HEIGHT SETTING WILL CAUSE DAMAGE TO CRIMP TOOLING.

-	-	-	1	-	-	-	2119957-2	APPLICATOR SHIM PACK	260
-	-	1	-	1	1	1	8-21084-0	O-RING, .676 ID, .070 DIA. MAT.	252
-	-	-	-	1	-	-	2119640-1	PUSH ROD, AIR FEED	250
-	-	-	-	-	1	-	2079988-1	BUSHING, LCH5-12, MISUMI	249
-78	-77	-7	-6	-5	-2	-1	PART NO	DESCRIPTION	ITEM NO

ATLANTIC VERSION
 Shown on sheets 1 of 4 & 2 of 4
 (Pacific version shown on sheets 3 of 4 & 4 of 4)

SET UP GAUGE	LOC	DIST	REVISIONS					
2119599-1	A	66	P	LTN	DESCRIPTION	DATE	OWN	APVD
			A1		ECR-14-003873	17MAR2014	RK	GB
			B		ECR-16-004049	17MAR2016	KH	CT
			B1		ECR-16-017319	07DEC2016	KH	JDG

-	-	-	-	-	1	-	2119641-1	FEED CAM, AIR FEED	248
-	-	1	-	1	1	1	2119798-1	DETENT PIN	247
-	-	1	-	1	1	1	1-22279-3	SPRING, COMPRESSION	246
-	-	-	1	-	-	-	2119758-1	RAM, AMP STYLE, SIDE FEED, NON-ADJ.	245
-	-	1	1	1	1	1	2119082-9	CAM, SNAIL, INSULATION ADJUSTMENT	244
-	-	1	1	1	1	1	2079764-1	WASHER, WAVE SPRING, CREST-TO-CREST	243
-	-	1	1	1	1	1	2119083-1	RETAINER, INSULATION DIAL	242
-	-	1	1	1	1	1	7-18023-7	SCR, SKT HD CAP M3 X 4.0	241
-	-	-	2	2	-	-	2168400-6	SHCS, LOW HEAD, RoHS, M5 X 16	240
-	-	-	-	-	-	1	2119580-1	MECHANICAL FEED ASSEMBLY	239
-	-	-	-	-	-	1	2063440-1	AIR FEED MODULE	238
-	-	-	1	1	-	-	2119740-2	TAG, IDENTIFICATION	213
-	-	-	1	1	-	-	1901094-3	SPACER, FEEDER	198
-	-	-	-	-	2	-	21045-3	RING, RETAIN, EXTERN, 3/16 CRESCENT	172
-	-	1	1	1	1	1	994969-1	MAGNET, RARE EARTH HIGH ENERGY	166
-	-	REF	REF	REF	REF	REF	994970-2	COUNTER, MAGNETIC	164
-	-	-	-	-	-	1	240638-1	SPRING, FEED FINGER	163
-	-	-	-	-	-	1	3-23627-7	PIN, RETAIN, GRVD, 3/16 X .854	137
-	-	-	-	-	-	1	2119799-1	HOLDER, FEED FINGER, AF	136
-	-	-	REF	REF	-	-	SEE NOTE 4	MEMORY CHIP, PROGRAMMED	135
-	-	-	1	1	-	-	1633743-1	SERVO FEED LATCH ASM	133
-	-	1	1	1	1	1	1-18028-2	WASHER, FLAT, REG M4	119
-	-	-	REF	REF	-	-	2119944-1	FEED FINGER ASSEMBLY,SF	117
-	-	1	1	1	1	1	2119955-1	ASSY, LUBRICATOR, SIDE FEED	113
-	-	1	1	1	1	1	455888-4	SPACER, CRIMPER	82
1	-	-	-	-	-	-	2266112	PRINT, APPLICATOR LOG SHEET	72
-	-	1	1	1	1	1	2119956-1	DOCUMENTATION PACKAGE	71
-	-	2	2	2	2	2	2119791-9	DEPRESSOR, WIRE	70
-	-	1	-	-	-	1	2119740-1	TAG, IDENTIFICATION	67
-	-	2	2	2	2	2	2168078-1	SCREW, DRIVE, RH, RoHS, 2 x .188	66
-	-	1	-	-	-	1	2119793-1	LIMITER, ADJUSTMENT BOLT	63
-	-	3	-	3	3	3	992763-5	SCR, SET, SOC, CONE POINT, M3 x 4.0	62
-	-	1	1	1	1	1	2079383-4	SCR, BHSC, RoHS (M4 X 8)	60
-	-	-	-	-	-	1	5-18022-5	SCR, HEX HD CAP, M4 X 6.0	59
-	-	-	-	-	-	1	1338683-8	FEED PAWL	56
-	-	4	4	4	4	4	2168400-1	SHCS, LOW HEAD, RoHS, M4 X 12	54
-	-	2	2	2	2	2	1-2168083-0	SCR, SKT HD CAP, RoHS, M4 X 10	53
-	-	1	1	1	1	1	5018030-1	NUT, HEX, REG, RoHS, M3	52
-	-	1	1	1	1	1	811242-5	BUMPER, HOLD DOWN	51
-	-	1	1	1	1	1	690753-2	SPACER, TONKER	50
-	-	-	-	-	-	1	18023-9	SCR, SKT HD CAP M4 X 6.0	49
-	-	-	-	-	-	1	2119652-1	FEED CAM, PRE FEED	48
-	-	-	-	-	-	1	2119653-1	FEED CAM, POST FEED	47
-	-	1	1	1	1	1	2119656-9	APPLICATOR BASIC ASSEMBLY, SF	46
-	-	1	-	-	-	1	2119370-1	RAM, AMP STYLE, SIDE FEED	44
-	-	1	1	1	1	1	2079383-7	SCR, BHSC, RoHS (M8 X 25)	41
-	-	1	-	-	-	1	2119645-1	DISC, NUMBERED FA WIRE ADJUSTMENT	40
-	-	1	-	-	-	1	2119957-1	APPLICATOR SHIM PACK	39
-	-	1	1	1	1	1	1-2119644-2	RAM WASHER, PRECISION	38
-	-	1	1	1	1	1	2119085-1	FA HEAD, ATLANTIC STYLE	37
-	-	1	-	-	-	1	2119092-1	BOLT, ADJUSTMENT	35
-	-	1	1	1	1	1	2-1752356-0	SUPPORT, TERMINAL	34
-	-	2	2	2	2	2	2079383-5	SCR, BHSC, RoHS (M4 X 20)	33
-	-	1	1	1	1	1	2161328-1	HEX HEAD, FLANGED, M5 x 8mm LONG	32
-	-	1	1	1	1	1	1-1320908-0	SPACER, STRIP GUIDE	30
-	-	1	1	1	1	1	2119959-1	ASSEMBLY, STRIP GUIDE	29
-	-	1	1	1	1	1	1320928-2	STRIP GUIDE	24
-	-	1	1	1	1	1	2168083-2	SCR, SKT HD CAP, RoHS, M4 X 8.0	21
-	-	1	1	1	1	1	1-18028-2	WASHER, FLAT, REG M4	20
-	-	1	1	1	1	1	2119533-1	STRIPPER, SIDE FEED	19
-	-	1	1	1	1	1	2119806-1	INSERT, SHEAR	13
-	-	1	1	1	1	1	3-22280-3	SPRING, COMPRESSION	12
-	-	1	1	1	1	1	1-356885-4	STOP, SHEAR	11
-	-	1	1	1	1	1	2119805-1	SHEAR HOLDER, FRONT	10
-	-	1	1	1	1	1	1803095-1	FLOATING SHEAR, FRONT	9
1	1	1	1	1	1	1	1803293-8	ANVIL, COMBINATION DEUTSCH STYLE	8
-	-	-	-	-	-	-	-	-	7
-	-	-	-	-	-	-	-	-	6
-	-	1	1	1	1	1	1-2119757-0	DEPRESSOR, SHEAR	5
-	-	1	1	1	1	1	238011-9	BLOCK, CRIMPER SPACER	4
1	1	1	1	1	1	1	1803019-3	CRIMPER, INSULATION O	3
-	-	1	1	1	1	1	455888-4	SPACER, CRIMPER	2
-	-	1	1	1	1	1	4-1633713-2	CRIMPER, WIRE PREMIUM	1

DIMENSIONS:		TOLERANCES UNLESS OTHERWISE SPECIFIED:		DRAWING NO	
mm	0 PLC	±		NAME	APVD
	1 PLC	±		DATE	10-Oct-13
	2 PLC	±		DATE	10-Oct-13
	3 PLC	±		DATE	10-Oct-13
	4 PLC	±		DATE	10-Oct-13
	ANGLES	±		DATE	10-Oct-13
	FINISH	±		DATE	10-Oct-13

Customer Accessible Production Drawing SCALE 1:2 SHEET 1 OF 4 REV B1

LOC		DIST		REVISIONS			
A	66	P	LTM	DESCRIPTION	DATE	OWN	APVD
		-		SEE SHEET 1			

FEED TYPE MECHANICAL

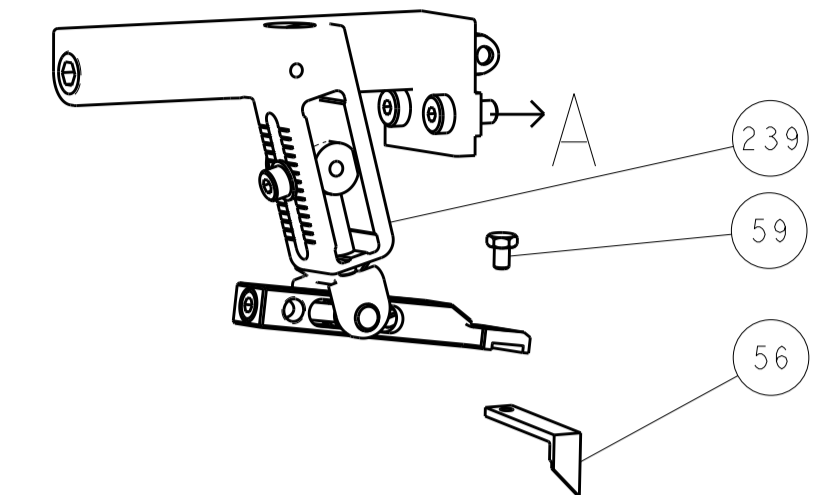

PNEUMATIC

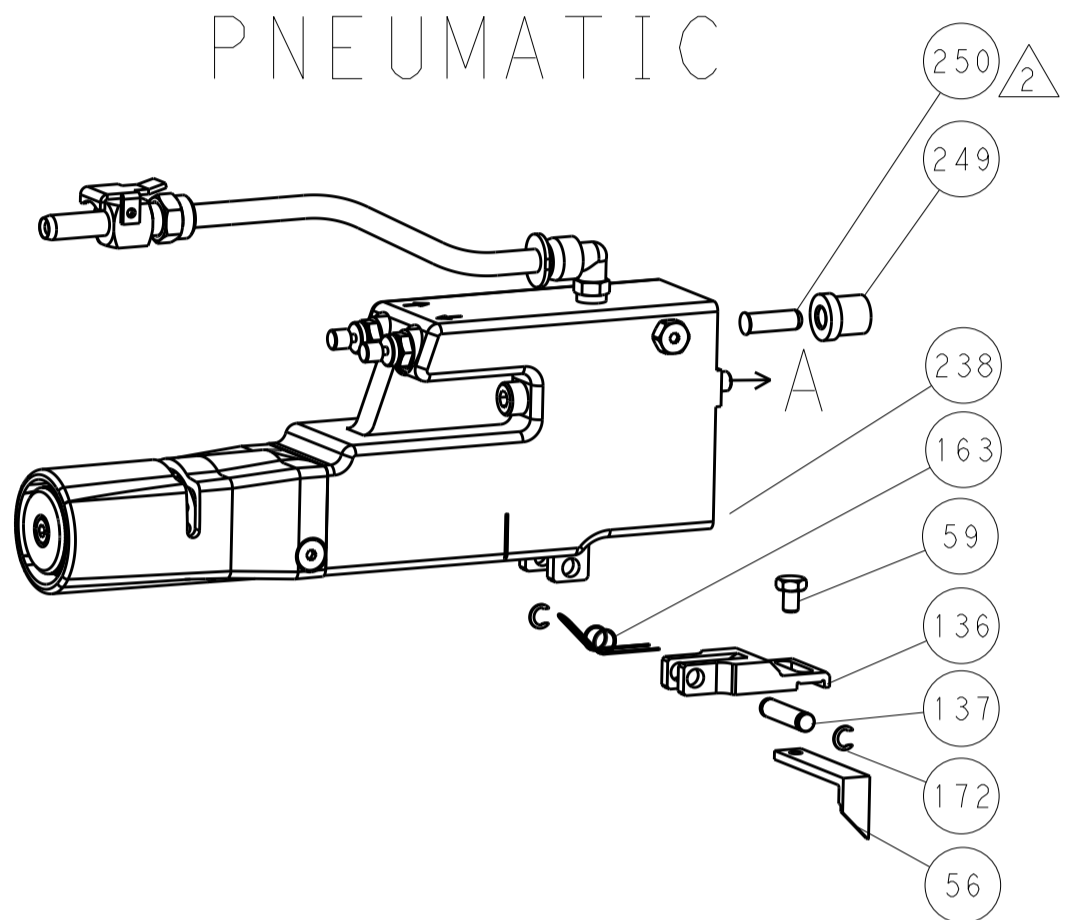

SERVO LATCH PLATE

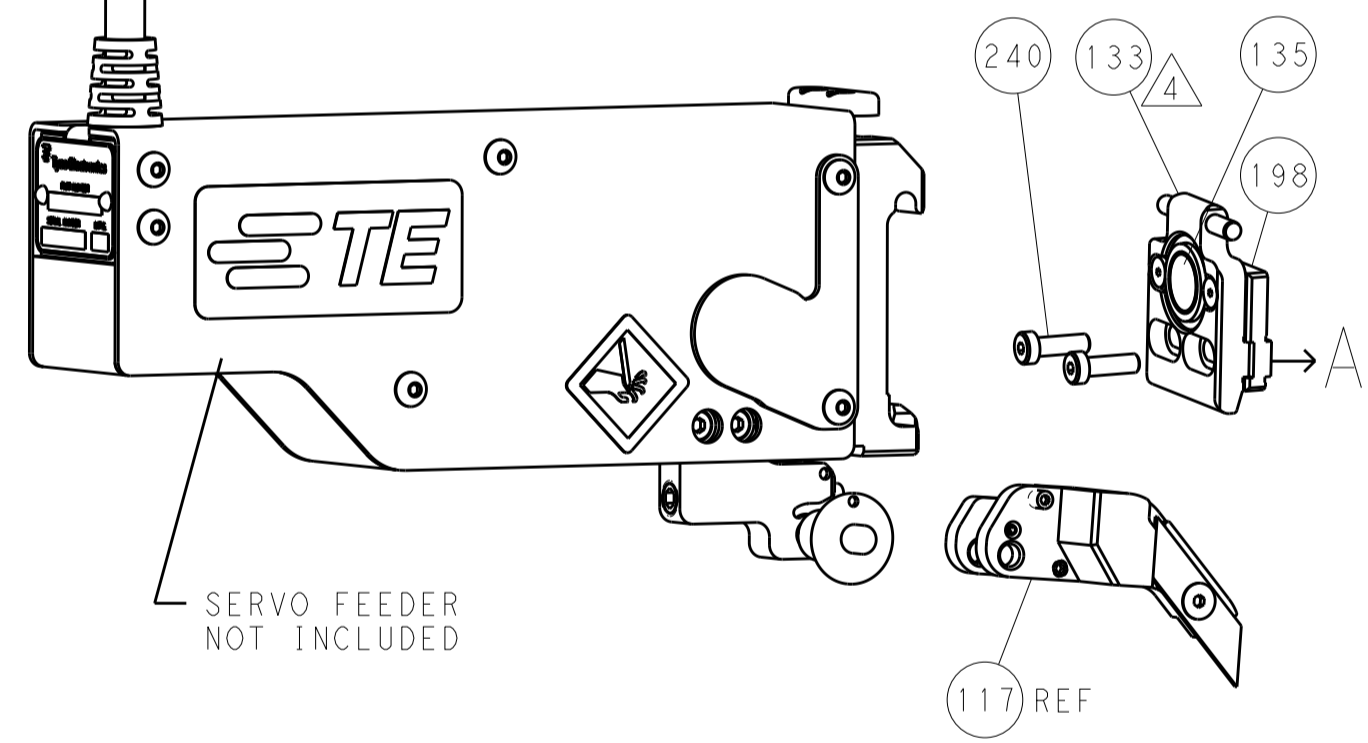

CAM POSITIONS

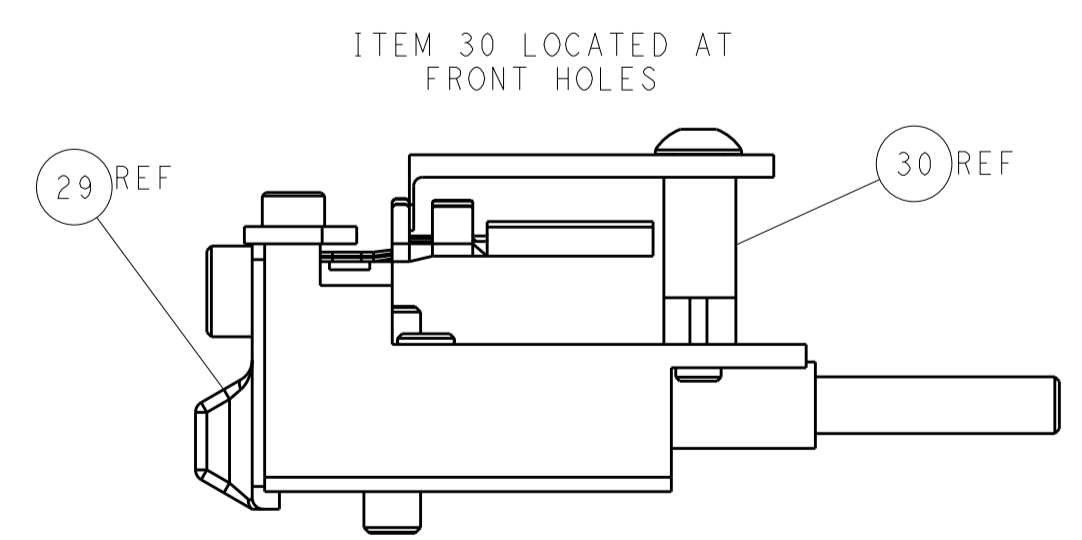
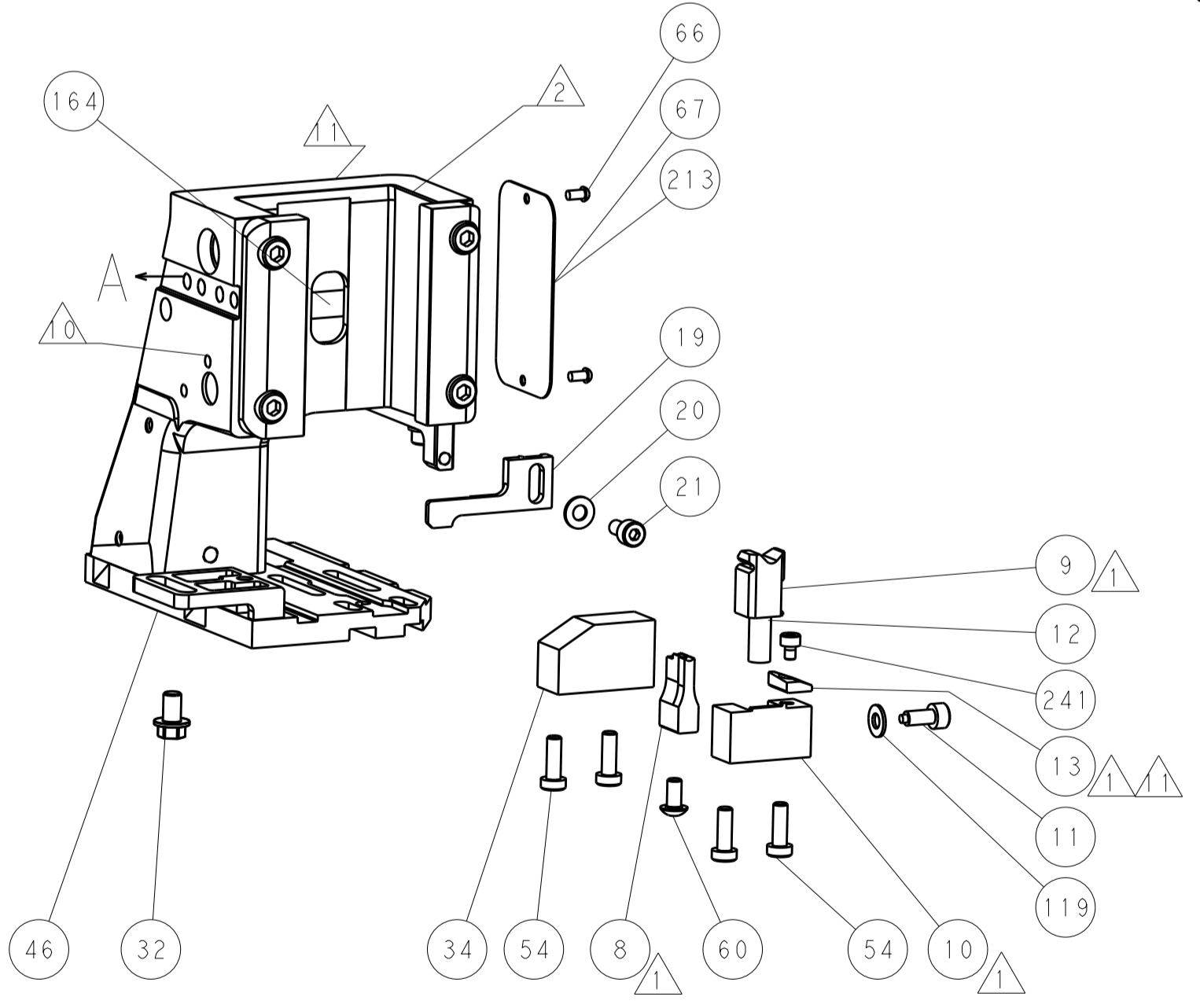
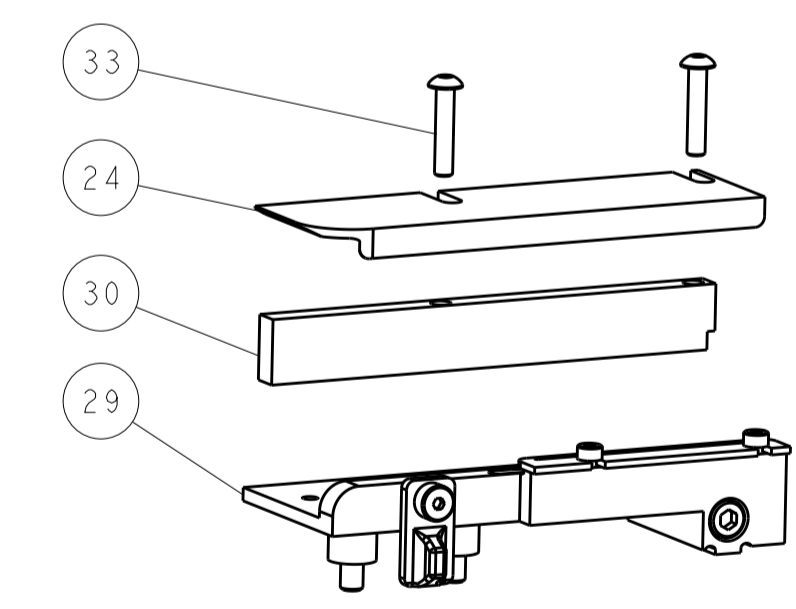
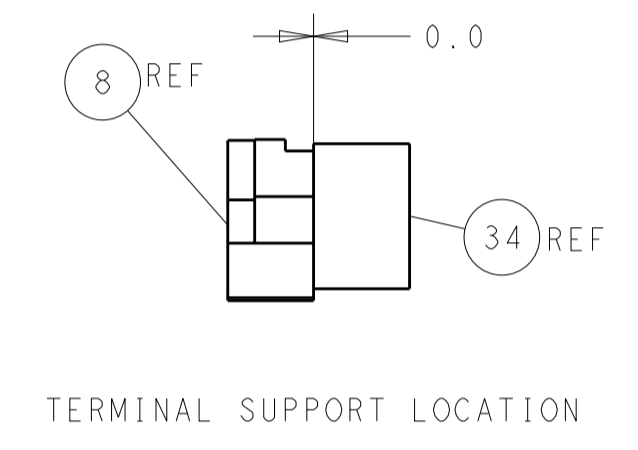
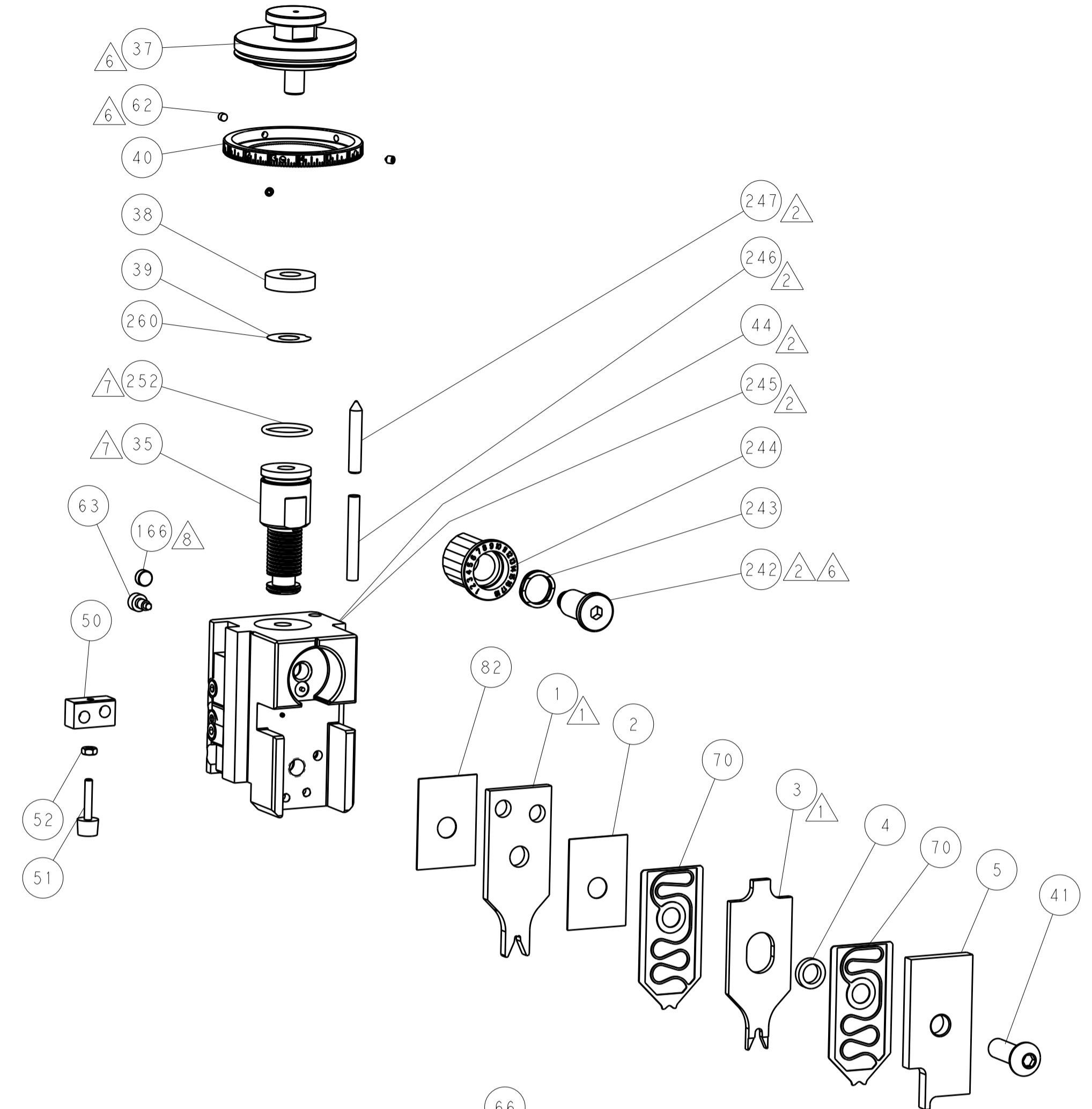
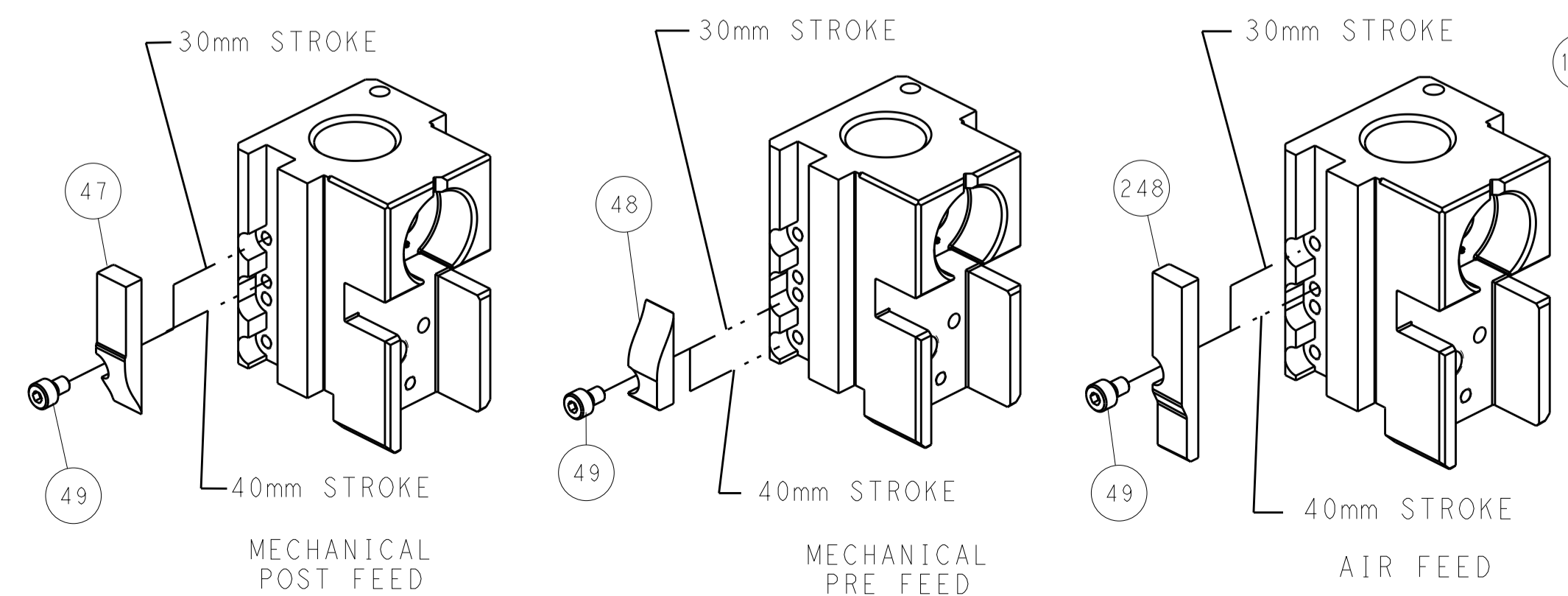

ATLANTIC VERSION
 Shown on sheets 1 of 4 & 2 of 4
 (Pacific version shown on sheets 3 of 4 & 4 of 4)

DIMENSIONS:		TOLERANCES UNLESS OTHERWISE SPECIFIED:		OWN: R. KNEPPER 10-Oct-13		TE Connectivity	
mm	0 PLC	±		CHK: G. BAILEY 10-Oct-13	NAME: Ocean Side Feed Applicator		Harrisburg, PA 17105-3608
	1 PLC	±		APVD: M. CLIFFORD 10-Oct-13	RESTRICTED TO:		
	2 PLC	±		PRODUCT SPEC:	SIZE: A11		CAGE CODE: 00779
	3 PLC	±		APPLICATION SPEC:	DRAWING NO: C=2266112		SCALE: 1:2
	4 PLC	±		WEIGHT:	SHEET 2 OF 4		REV: B1
MATERIAL:	FINISH:			Customer Accessible Production Drawing		SHEETS 3 & 4 ARE NOT REQUIRED FOR ATLANTIC VERSION	

PACIFIC VERSION TERMINATOR INTERFACE ADAPTER	PART NUMBER	REVISION	DESCRIPTION	FEED TYPE
	2-2266112-1	B	FINE CRIMP HEIGHT ADJUST	MECHANICAL
	2-2266112-2	B	FINE CRIMP HEIGHT ADJUST	PNEUMATIC
	2-2266112-5	B	FINE CRIMP HEIGHT ADJUST	SERVO LATCH PLATE
	2-2266112-7	B	FINE CRIMP HEIGHT ADJUST	NONE
	7-2266112-7	B	CRIMP TOOLING KIT	-
	7-2266112-8	B	APPLICATOR CONVERSION KIT	-

APPLICATOR STYLE CONVERSION CHART									
CONVERT TO	PART NUMBERS REQUIRED								
PNEUMATIC FEED	2119950-1	1338683-8	5-18022-5	2119641-2	2119799-1	2063440-1			
SERVO LATCH PLATE	2119951-1	-	8-2266112-5	1901094-3	-	2168400-6 (QUANTITY 2)			
SMART APPLICATOR	2161326-1	-	8-2266112-4	-	-	-			
MECHANICAL FEED	2119949-1	1338683-8	5-18022-5	2119653-2	-	-			
SERVO LATCH PLATE	2119951-1	-	8-2266112-5	1901094-3	-	2168400-6 (QUANTITY 2)			
SMART APPLICATOR	2161326-1	-	8-2266112-4	-	-	-			
MECHANICAL FEED	2119949-1	1338683-8	5-18022-5	2119653-2	-	-			
PNEUMATIC FEED	2119950-1	1338683-8	5-18022-5	2119641-2	2119799-1	2063440-1			

APPLICATOR DATA		
CRIMP	SIZE	TYPE
WIRE	2.62 mm [.103]	F
INSUL	3.20 mm [.126]	O
APPLICATOR INSTRUCTIONS 408-10389		

APPLICATOR CONVERSION KITS	
PART NUMBER	INSULATION DIAMETER RANGE
7-2266112-8	Ø3.15-3.56mm [.124-.140]
7-2266113-8	Ø2.72-3.12mm [.107-.123]
7-2266114-8	Ø2.29-2.69mm [.090-.106]
7-2266115-8	Ø1.91-2.26mm [.075-.089]

TERMINAL DATA: DEUTSCH TERMINAL DEUTSCH CRIMP SPECIFICATION			
TERMINAL NAME: STAMPED CONTACT PIN SIZE 16			
WIRE STRIP LENGTH		INSULATION DIAMETER RANGE	
4.44-5.72 mm [.175-.225 IN]		Ø3.15-3.56 mm [.124-.140 IN]	
TERMINAL APPLICATION SPECIFICATION	0425-039-0000 Rev E	-	-
TERMINALS APPLIED			
TE TERMINAL	DEUTSCH TERMINAL	TE TERMINAL	DEUTSCH TERMINAL
2113238-1	1060-16-1222	2113238-2	1060-16-1244
2113238-3	1060-16-1277		

TERMINAL DATA: DEUTSCH TERMINAL DEUTSCH CRIMP SPECIFICATION			
TERMINAL NAME: STAMPED CONTACT SOCKET SIZE 16			
WIRE STRIP LENGTH		INSULATION DIAMETER RANGE	
4.44-5.72 mm [.175-.225 IN]		Ø3.15-3.56 mm [.124-.140 IN]	
TERMINAL APPLICATION SPECIFICATION	0425-039-0000 Rev E	-	-
TERMINALS APPLIED			
TE TERMINAL	DEUTSCH TERMINAL	TE TERMINAL	DEUTSCH TERMINAL
1949119-1	1062-16-1222	1949119-2	1062-16-1244
1949119-3	1062-16-1277	1949119-4	1062-16-1422
1949119-5	1062-16-1444	1949119-6	1062-16-1477

WIRE SIZE	CRIMP HEIGHT mm [INCH]	CRIMP HEIGHT REFERENCE SETTING
12 AWG	1.78+0.03/-0.05 [.070+.001/-0.002]	5.6
2.50mm2	1.73+0.03/-0.05 [.068+.001/-0.002]	6.1
14 AWG	1.65+0.03/-0.05 [.065+.001/-0.002]	6.7
2.00mm2	1.63+0.03/-0.05 [.064+.001/-0.002]	6.9
1.50mm2	1.50+0.03/-0.05 [.059+.001/-0.002]	8.2
16 AWG	1.47+0.03/-0.05 [.058+.001/-0.002]	8.5
1.00mm2	1.40+0.03/-0.05 [.055+.001/-0.002]	9.3

- RECOMMENDED SPARE PARTS
- GREASE BEARING SURFACES LIGHTLY
- LUBRICATE DAILY PER THE APPLICATOR INSTRUCTION SHEET SUPPLIED WITH THE APPLICATOR.
- APPLICATOR SPECIFIC DATA TO BE ENTERED INTO BLANK MEMORY CHIP AT ASSEMBLY. SEE BELOW FOR PART NUMBER:
 MECHANICAL FEED WITH "SMART APPLICATOR" CONVERSION: 8-2266112-4
 PNEUMATIC FEED WITH "SMART APPLICATOR" CONVERSION: 8-2266112-4
 SERVO FEED WITH "FINE CRIMP HEIGHT ADJUST": 8-2266112-5
- ADJUSTMENT OF THE STRIPPER MAY BE REQUIRED WHEN MOVING THE APPLICATOR BETWEEN BENCH AND LEADMAKER APPLICATIONS.
- APPLY PART NUMBER 1-23419-5 LOCTITE TO THREADS OF ITEMS 62.
 APPLY PART NUMBER 2-23419-6 LOCTITE TO THREADS OF ITEMS 242.
- GREASE THREADS, GROOVE AND O-RING ON ITEMS 139 & 152.
- MAGNET MUST BE ORIENTED CORRECTLY IN ORDER TO PROPERLY ACTUATE THE COUNTER.
- CRIMP HEIGHT REFERENCE SETTING WAS THE SETTING USED WHEN THE APPLICATOR WAS QUALIFIED AT THE FACTORY. ADJUSTMENT MAY BE NECESSARY WHEN RUNNING APPLICATOR IN THE FIELD.
- SPARE FEED CAM STORAGE LOCATION REFER TO INSTRUCTION SHEET FOR ADDITIONAL INFORMATION.
- TO CONVERT THE APPLICATOR TO A NON-CARRIER CUTTING STYLE, REMOVE ITEM 13 AND ATTACH TO THE LOCATION ON BACK SIDE OF THE HOUSING. REFER TO INSTRUCTION SHEET FOR ADDITIONAL INFORMATION.
- SEE APPROPRIATE APPLICATOR LOG SHEETS FOR APPLIED TERMINALS, WIRE RANGE AND MEMORY CHIP.
- TERMINAL LUBRICANT IS RECOMMENDED.

***WARNING**
 ON INSTALLATION, SET WIRE DISC, ITEM 40 TO LARGEST WIRE SIZE SETTING. USE OF SETTINGS BELOW MINIMUM REQUIRED CRIMP HEIGHT SETTING WILL CAUSE DAMAGE TO CRIMP TOOLING.

-78 -77 -27 -25 -22 -21	PART NO	DESCRIPTION	ITEM NO
-	2119782-1	FINE ADJUST HEAD ASM, PACIFIC STYLE	251
-	2119640-1	PUSH ROD, AIR FEED	250

PACIFIC VERSION
 Shown on sheets 3 of 4 & 4 of 4
 (Atlantic version shown on sheets 1 of 4 & 2 of 4)

SET UP GAUGE	LOC	DIST	REVISIONS					
2119599-1	A	66	P	LTN	DESCRIPTION	DATE	OWN	APVD
			-	-	SEE SHEET 1	-	-	-

-	-	-	-	1	-	2079988-1	BUSHING, LCH5-12, MISUMI	249	
-	-	1	1	1	1	1-22279-3	SPRING, COMPRESSION	246	
-	-	1	1	1	1	2119082-9	CAM, SNAIL, INSULATION ADJUSTMENT	244	
-	-	1	1	1	1	2079764-1	WASHER, WAVE SPRING, CREST-TO-CREST	243	
-	-	1	1	1	1	2119083-1	RETAINER, INSULATION DIAL	242	
-	-	1	1	1	1	7-18023-7	SCR, SKT HD CAP M3 X 4.0	241	
-	-	-	2	-	-	2168400-6	SHCS, LOW HEAD, RoHS, M5 X 16	240	
-	-	-	-	-	1	2119580-1	MECHANICAL FEED ASSEMBLY	239	
-	-	-	-	-	1	2063440-1	AIR FEED MODULE	238	
-	-	-	1	-	-	2119740-2	TAG, IDENTIFICATION	213	
-	-	-	1	-	-	1901094-3	SPACER, FEEDER	198	
-	-	-	-	2	-	21045-3	RING, RETAIN, EXTERN, 3/16 CRESCENT	172	
-	-	1	1	1	1	994969-1	MAGNET, RARE EARTH HIGH ENERGY	166	
-	-	REF	REF	REF	REF	994970-2	COUNTER, MAGNETIC	164	
-	-	-	-	1	-	240638-1	SPRING, FEED FINGER	163	
-	-	1	1	1	1	8-21084-1	O-RING, .801 ID, .070 DIA. MAT.	152	
-	-	-	-	-	1	2119641-2	FEED CAM, AIR FEED	151	
-	-	1	1	1	1	2119798-2	DETENT PIN	145	
-	-	1	1	1	1	2079383-8	SCR, BHSC, RoHS (M4 X 16)	144	
-	-	4	4	4	4	2168400-5	SHCS, LOW HEAD, RoHS, M4 X 20	143	
-	-	-	-	-	1	2119653-2	FEED CAM, POST FEED	142	
-	-	1	1	1	1	1-2119656-0	APPLICATOR BASIC ASSEMBLY, SF	141	
-	-	1	1	1	1	2119650-1	RAM, ASIAN STYLE, SIDE FEED	140	
-	-	1	1	1	1	2119092-2	BOLT, ADJUSTMENT	139	
-	-	-	-	1	-	3-23627-7	PIN, RETAIN, GRVD, 3/16 X .854	137	
-	-	-	-	-	1	2119799-1	HOLDER, FEED FINGER, AF	136	
-	-	-	-	REF	-	-	SEE NOTE 4	MEMORY CHIP, PROGRAMMED	135
-	-	-	-	1	-	1633743-1	SERVO FEED LATCH ASM	133	
-	-	1	1	1	1	1-18028-2	WASHER, FLAT, REG M4	119	
-	-	-	-	REF	-	-	-	FEED FINGER ASSEMBLY, SF	117
-	-	1	1	1	1	2119955-1	ASSY, LUBRICATOR, SIDE FEED	113	
-	-	1	1	1	1	455888-4	SPACER, CRIMPER	82	
1	-	-	-	-	-	2266112	PRINT, APPLICATOR LOG SHEET	72	
-	-	1	1	1	1	2119956-1	DOCUMENTATION PACKAGE	71	
-	-	2	2	2	2	2119791-9	DEPRESSOR, WIRE	70	
-	-	1	-	1	1	2119740-1	TAG, IDENTIFICATION	67	
-	-	2	2	2	2	2168078-1	SCREW, DRIVE, RH, RoHS, 2 x .188	66	
-	-	1	1	1	1	2119793-1	LIMITER, ADJUSTMENT BOLT	63	
-	-	3	3	3	3	992763-5	SCR, SET, SOC, CONE POINT, M3 X 4.0	62	
-	-	-	-	-	1	5-18022-5	SCR, HEX HD CAP, M4 X 6.0	59	
-	-	-	-	-	1	1338683-8	FEED PAWL	56	
-	-	2	2	2	2	1-2168083-0	SCR, SKT HD CAP, RoHS, M4 X 10	53	
-	-	1	1	1	1	5018030-1	NUT, HEX, REG, RoHS, M3	52	
-	-	1	1	1	1	811242-5	BUMPER, HOLD DOWN	51	
-	-	1	1	1	1	690753-2	SPACER, TONKER	50	
-	-	-	-	-	1	18023-9	SCR, SKT HD CAP M4 X 6.0	49	
-	-	-	-	-	1	2119652-1	FEED CAM, PRE FEED	48	
-	-	1	1	1	1	2079383-7	SCR, BHSC, RoHS (M8 X 25)	41	
-	-	1	1	1	1	2119645-1	DISC, NUMBERED FA WIRE ADJUSTMENT	40	
-	-	1	1	1	1	2119957-1	APPLICATOR SHIM PACK	39	
-	-	1	1	1	1	1-2119644-2	RAM WASHER, PRECISION	38	
-	-	1	1	1	1	2-1752356-0	SUPPORT, TERMINAL	34	
-	-	2	2	2	2	2079383-5	SCR, BHSC, RoHS (M4 X 20)	33	
-	-	1	1	1	1	2161328-1	HEX HEAD, FLANGED, M5 X 8mm LONG	32	
-	-	1	1	1	1	1-1320908-0	SPACER, STRIP GUIDE	30	
-	-	1	1	1	1	2119959-1	ASSEMBLY, STRIP GUIDE	29	
-	-	1	1	1	1	1320928-2	STRIP GUIDE	24	
-	-	1	1	1	1	2168083-2	SCR, SKT HD CAP, RoHS, M4 X 8.0	21	
-	-	1	1	1	1	1-18028-2	WASHER, FLAT, REG M4	20	
-	-	1	1	1	1	2119533-1	STRIPPER, SIDE FEED	19	
-	-	1	1	1	1	2119806-1	INSERT, SHEAR	13	
-	-	1	1	1	1	3-22280-3	SPRING, COMPRESSION	12	
-	-	1	1	1	1	1-356885-4	STOP, SHEAR	11	
-	-	1	1	1	1	2119805-1	SHEAR HOLDER, FRONT	10	
-	-	1	1	1	1	1803095-1	FLOATING SHEAR, FRONT	9	
1	1	1	1	1	1	1803293-8	ANVIL, COMBINATION DEUTSCH STYLE	8	
-	-	-	-	-	-	-	-	7	
-	-	-	-	-	-	-	-	6	
-	-	1	1	1	1	1-2119757-0	DEPRESSOR, SHEAR	5	
-	-	1	1	1	1	238011-9	BLOCK, CRIMPER SPACER	4	
1	1	1	1	1	1	1803019-3	CRIMPER, INSULATION O	3	
-	-	1	1	1	1	455888-4	SPACER, CRIMPER	2	
-	-	1	1	1	1	4-1633713-2	CRIMPER, WIRE PREMIUM	1	

DIMENSIONS:		TOLERANCES UNLESS OTHERWISE SPECIFIED:		APPROVED:		DATE:	
mm	0 PLC ±	1 PLC ±	2 PLC ±	APVD	DATE	REV	DATE
	3 PLC ±	4 PLC ±	ANGLES	DATE			
	FINISH			DATE			
MATERIAL		WEIGHT		DATE			
		Customer Accessible Production Drawing	SCALE	SHEET	OF	REV	

LOC		DIST		REVISIONS			
A	66	P	LTM	DESCRIPTION	DATE	OWN	APVD
		-	-	SEE SHEET 1	-	-	-

FEED TYPE MECHANICAL

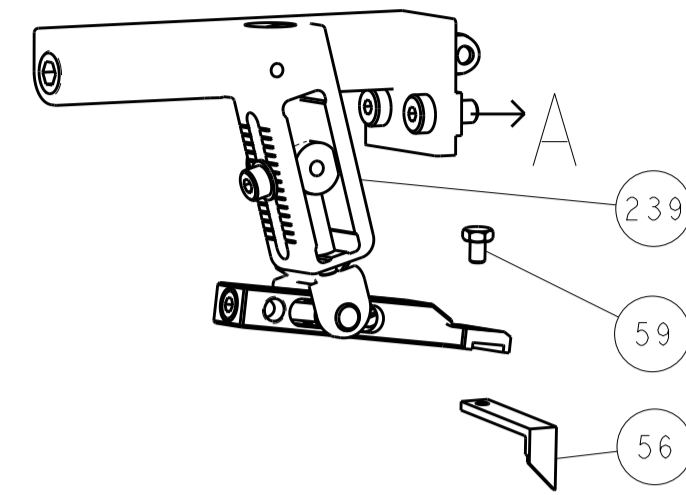

PNEUMATIC

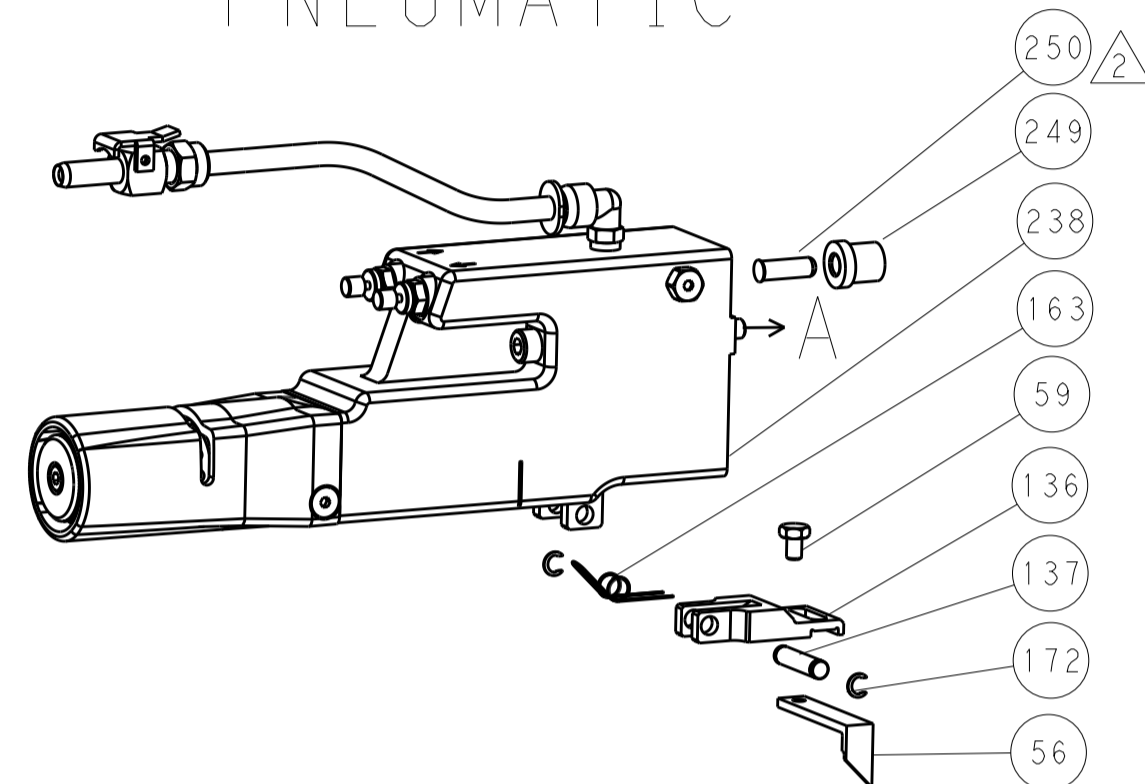

SERVO LATCH PLATE

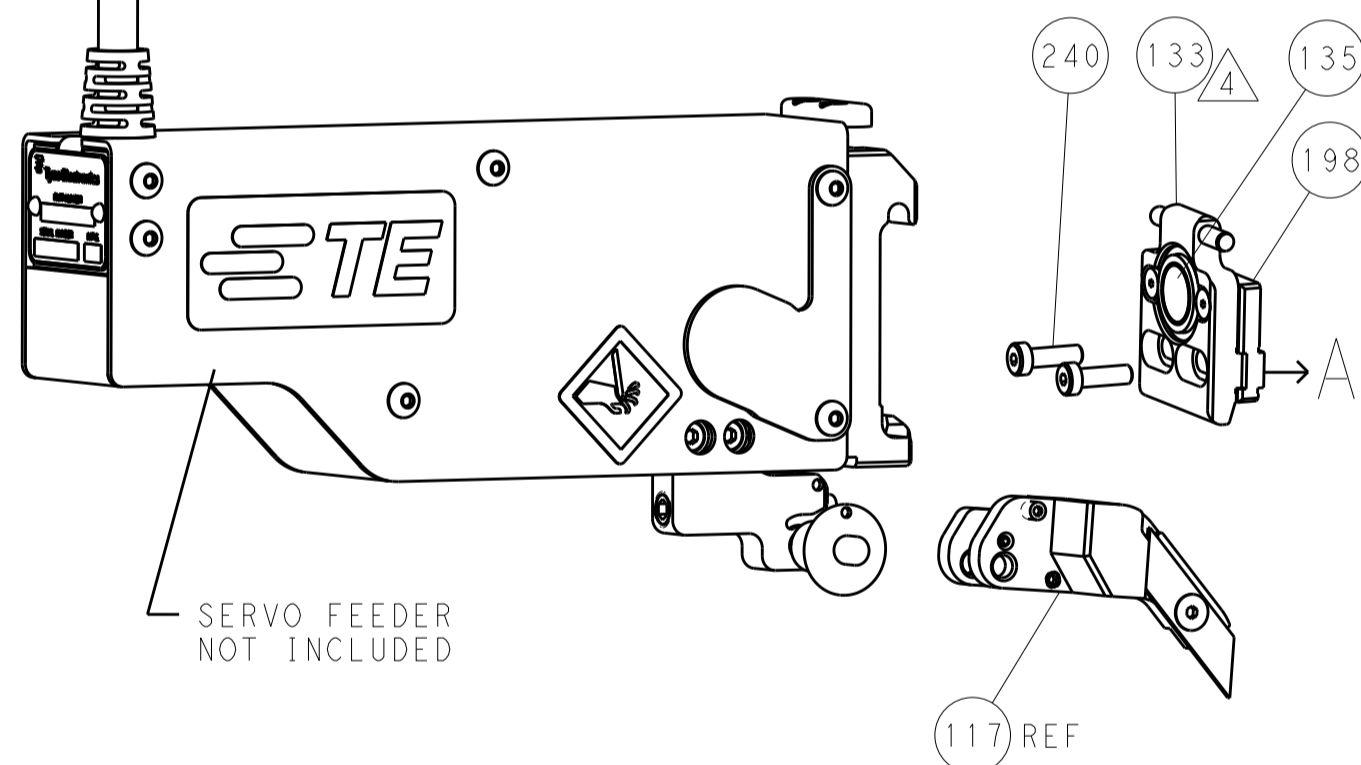

CAM POSITIONS

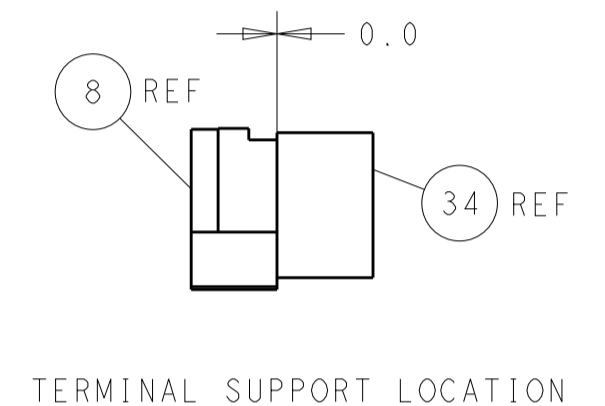
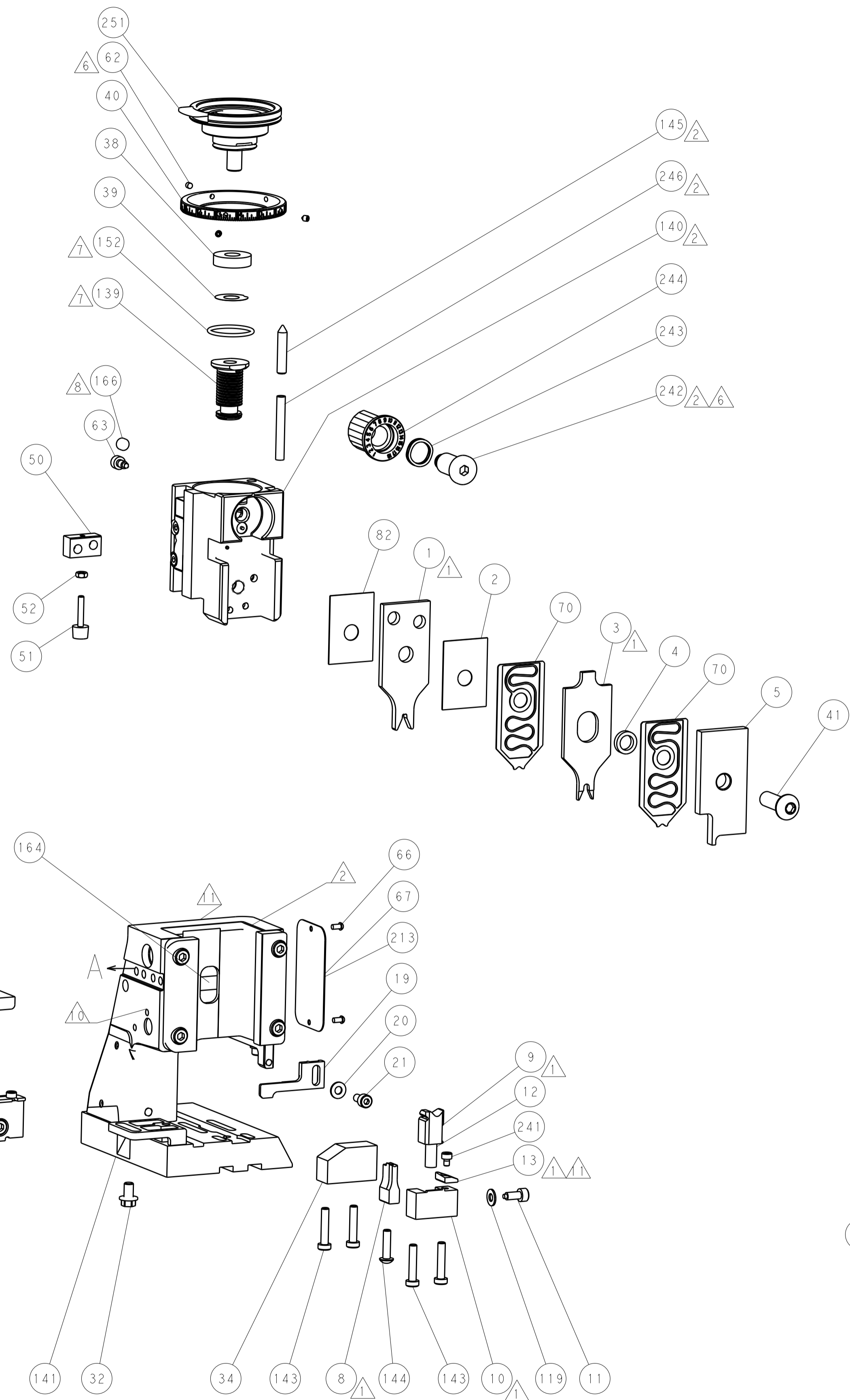
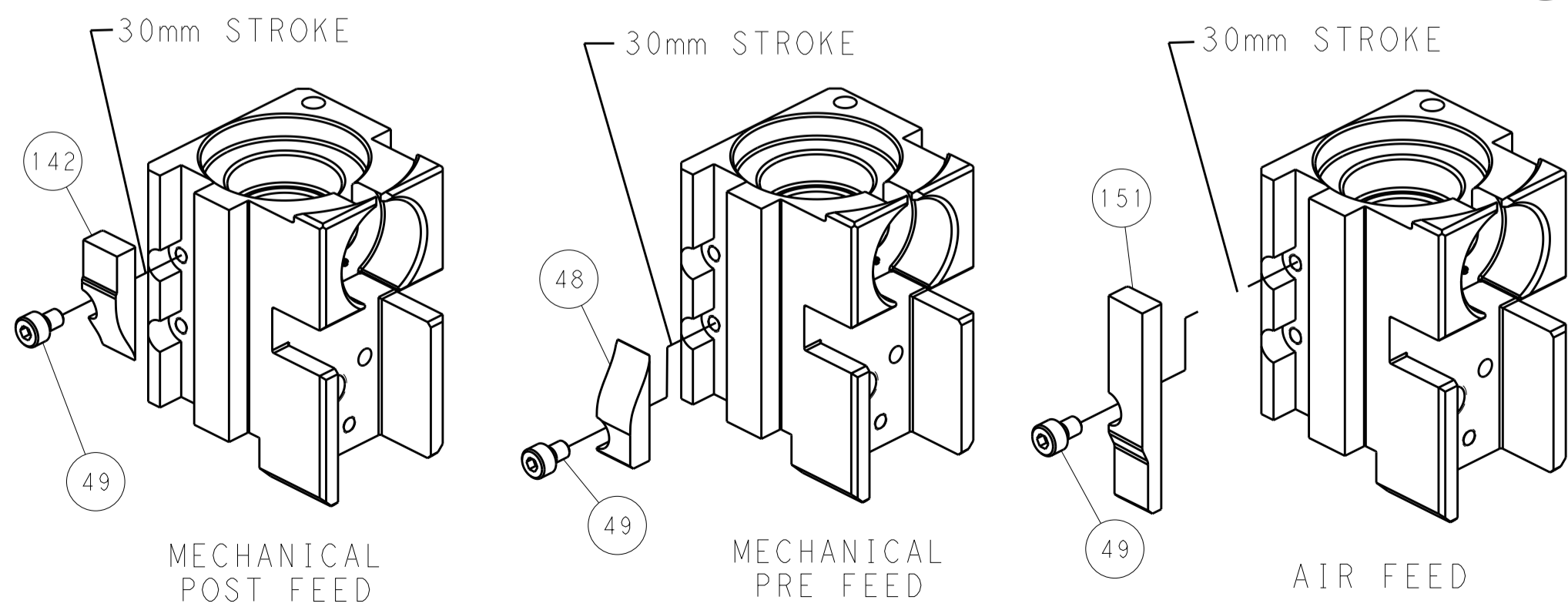

TERMINAL SUPPORT LOCATION

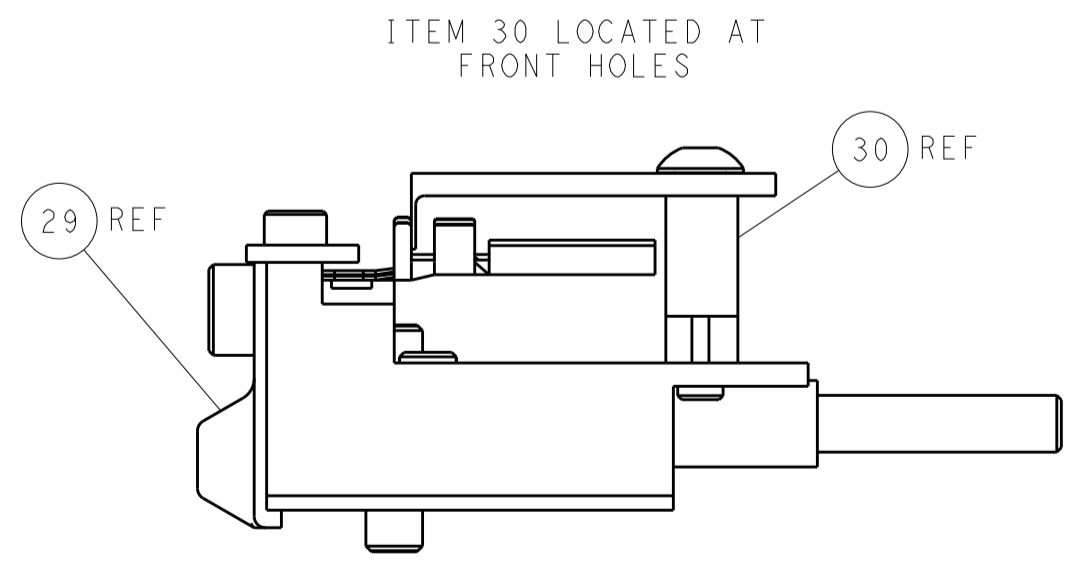

FEED TRACK POSITION GUIDE BY INSULATION BARREL

PACIFIC VERSION
 Shown on sheets 3 of 4 & 4 of 4
 (Atlantic version shown on sheets 1 of 4 & 2 of 4)

DIMENSIONS:		TOLERANCES UNLESS OTHERWISE SPECIFIED:		DWN R. KNEPPER 10-Oct-13		STE TE Connectivity	
mm	0 PLC ±	1 PLC ±	2 PLC ±	3 PLC ±	4 PLC ±	5 PLC ±	Harrisburg, PA 17105-3608
MATERIAL:		FINISH:		CHK G. BAILEY 10-Oct-13		NAME Ocean Side Feed Applicator	
				APVD M. CLIFFORD 10-Oct-13		SIZE CAGE CODE DRAWING NO	
				PRODUCT SPEC		RESTRICTED TO	
				APPLICATION SPEC		A 00779 C=2266112	
				WEIGHT		SCALE 1:2 SHEET 4 OF 4 REV B1	
				Customer Accessible Production Drawing		Customer Accessible Production Drawing	