

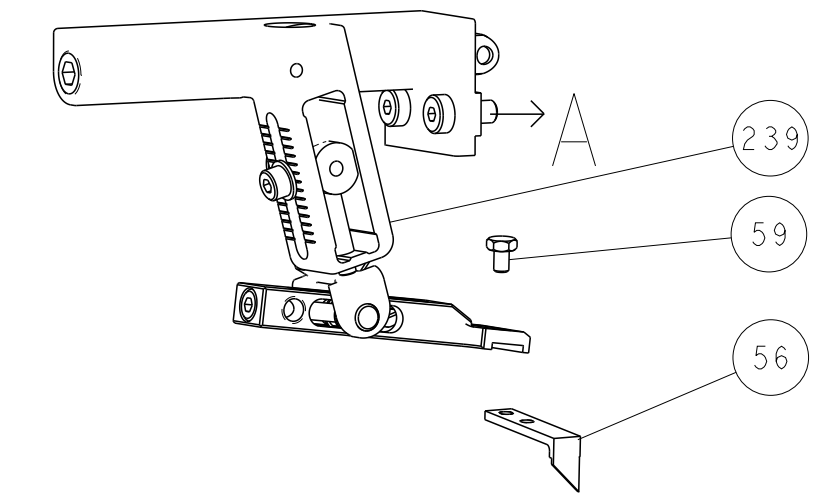

LOC	DIST	REV	DATE	BY	APPV
A	66				

### FEED TYPE MECHANICAL



### PNEUMATIC

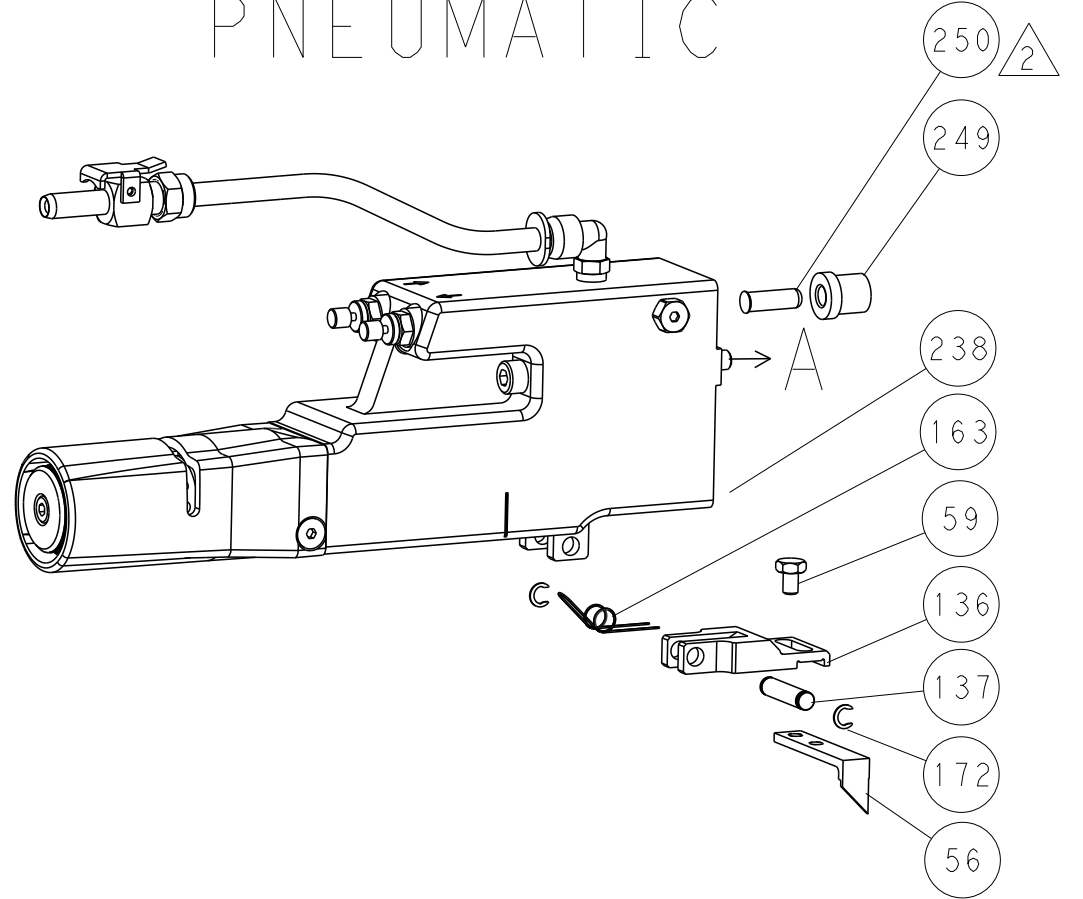

### SERVO LATCH PLATE

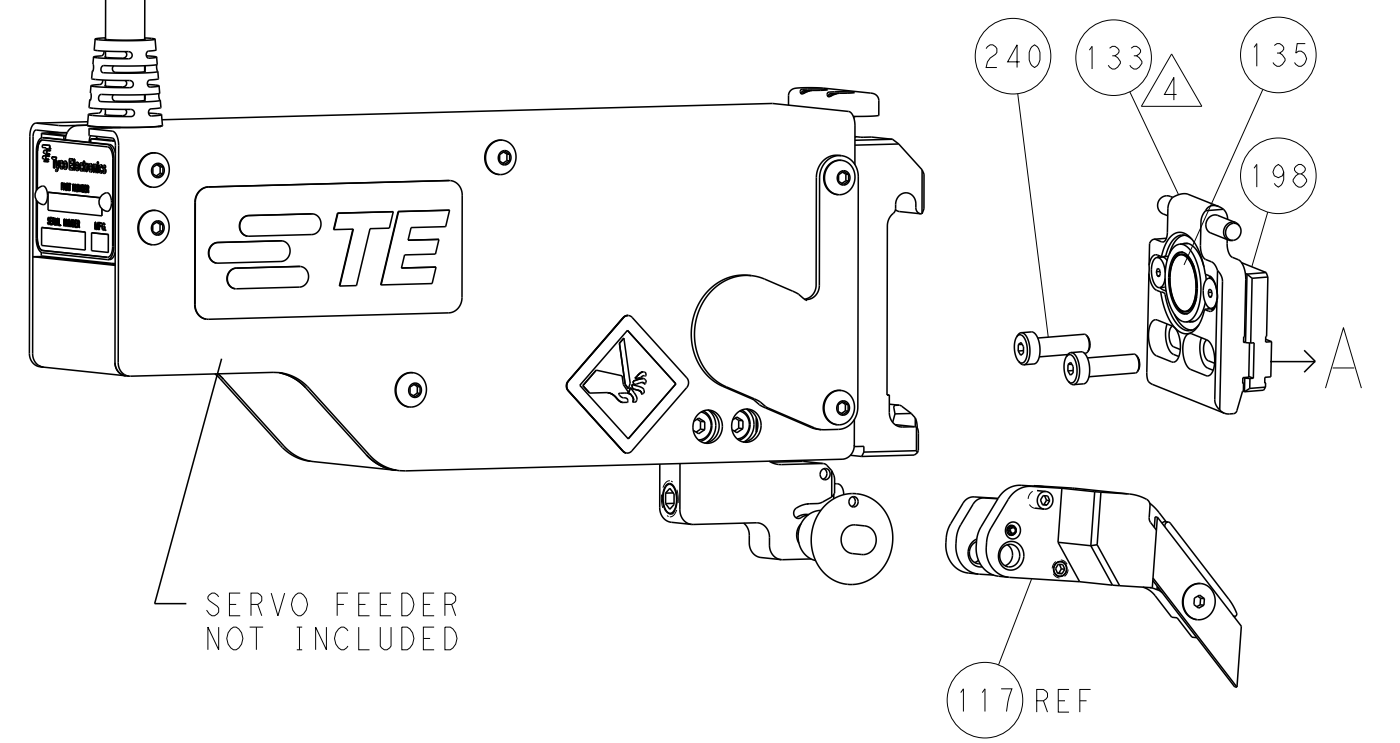

### CAM POSITIONS

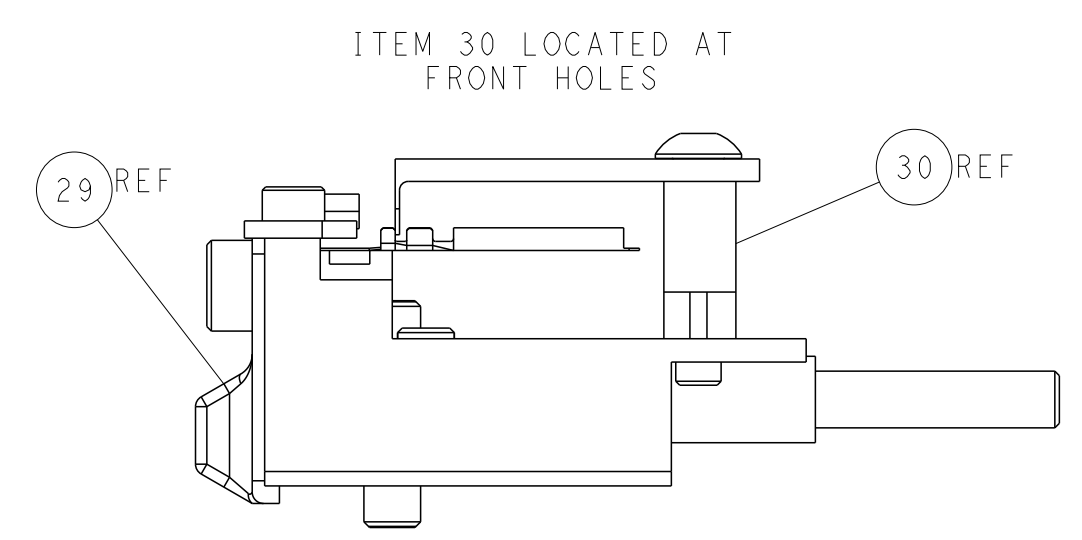
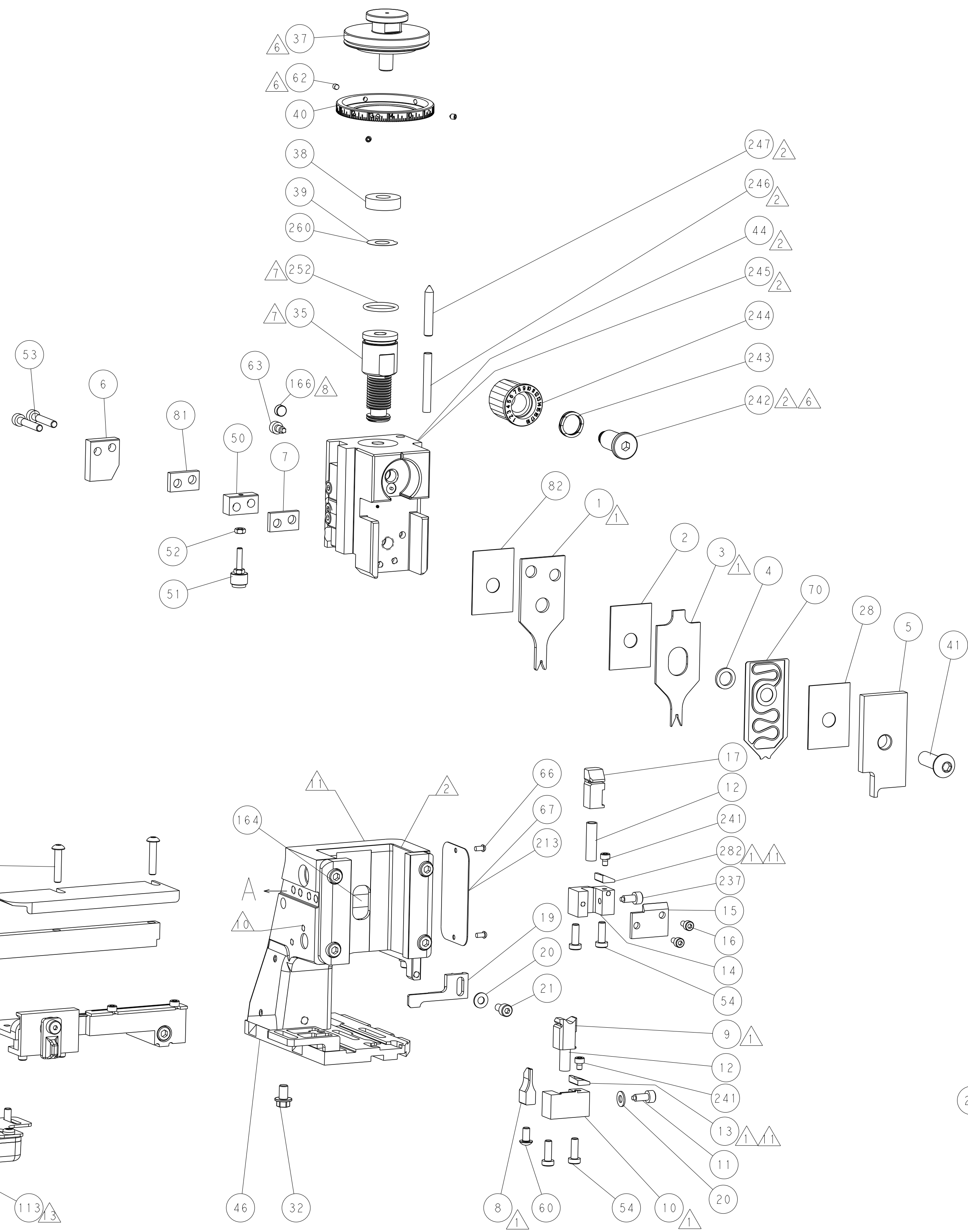
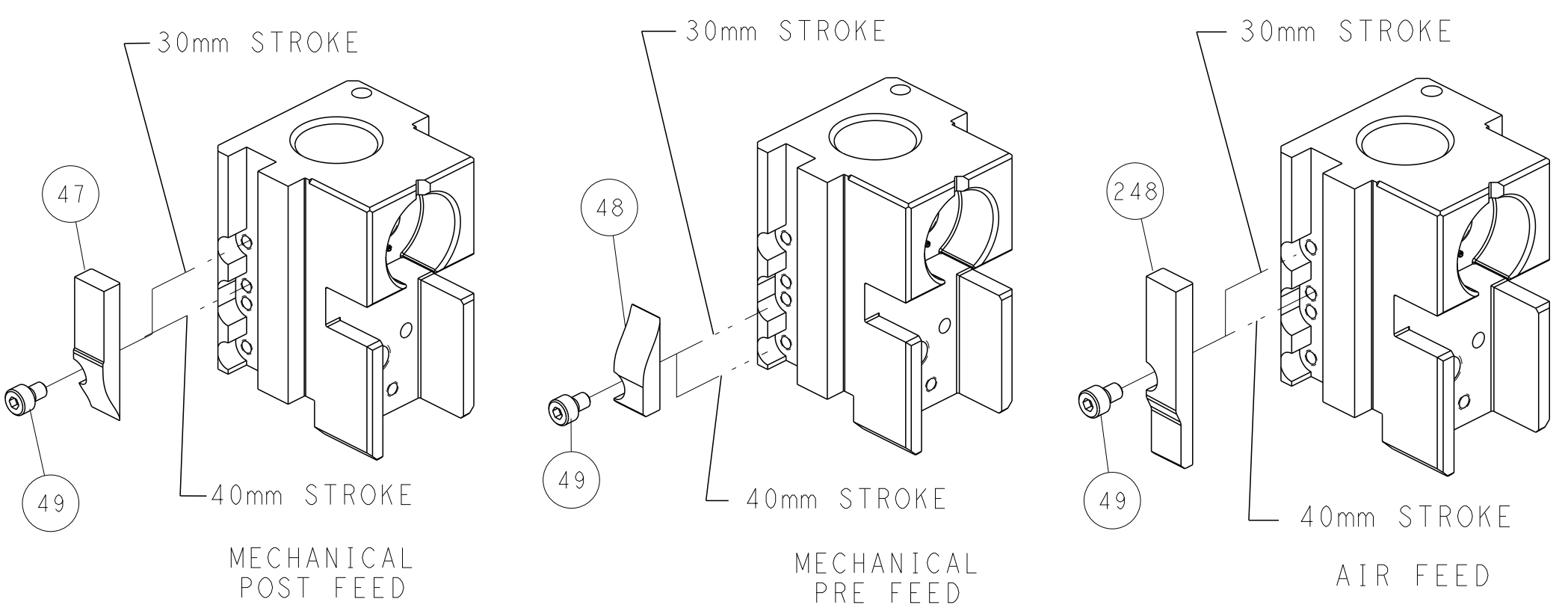

**ATLANTIC VERSION**  
 Shown on sheets 1 of 4 & 2 of 4  
 (Pacific version shown on sheets 3 of 4 & 4 of 4)

DIMENSIONS: mm 		TOLERANCES UNLESS OTHERWISE SPECIFIED: 0 PLC ± 1 PLC ± 3 PLC ± 4 PLC ± ANGLES ± FINISH ±		DWN R. HUANG 22SEP2014 CHK L. ZHANG 22SEP2014 APVD J. GUO 22SEP2014 PRODUCT SPEC APPLICATION SPEC WEIGHT Customer Accessible Production Drawing		NAME Ocean Side Feed Applicator SIZE CAGE CODE DRAWING NO. RESTRICTED TO A1 00779 C=2266492 SCALE 1:2 SHEET 2 OF 4 REV A	
-----------------------	--	------------------------------------------------------------------------------------------------------------	--	-------------------------------------------------------------------------------------------------------------------------------------------------------------------	--	-----------------------------------------------------------------------------------------------------------------------------------	--



LOC		DIST		REVISIONS			
A	66	P	LTM	DESCRIPTION	DATE	OWN	APVD
		-		SEE SHEET 1			

# FEED TYPE MECHANICAL

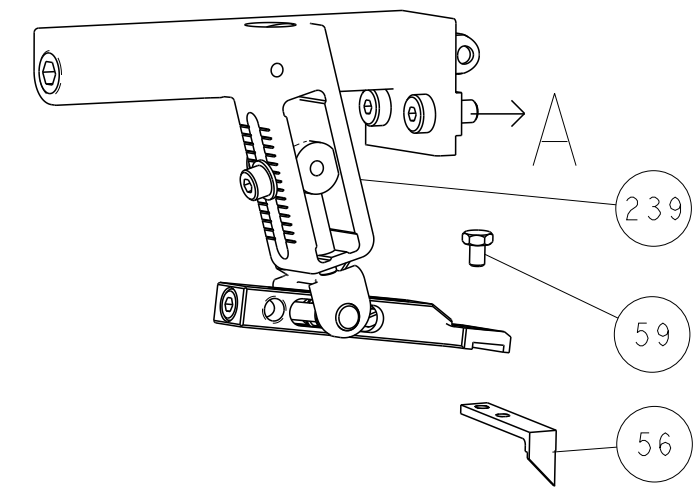

# PNEUMATIC

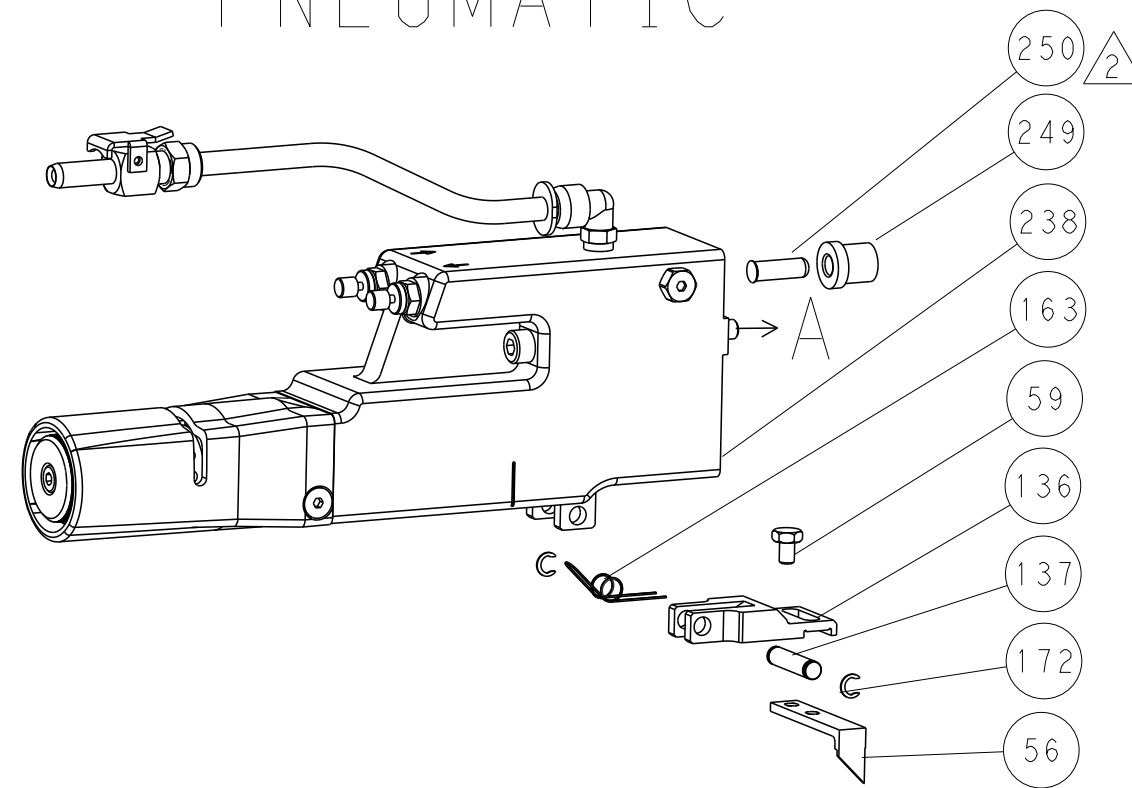

# SERVO LATCH PLATE

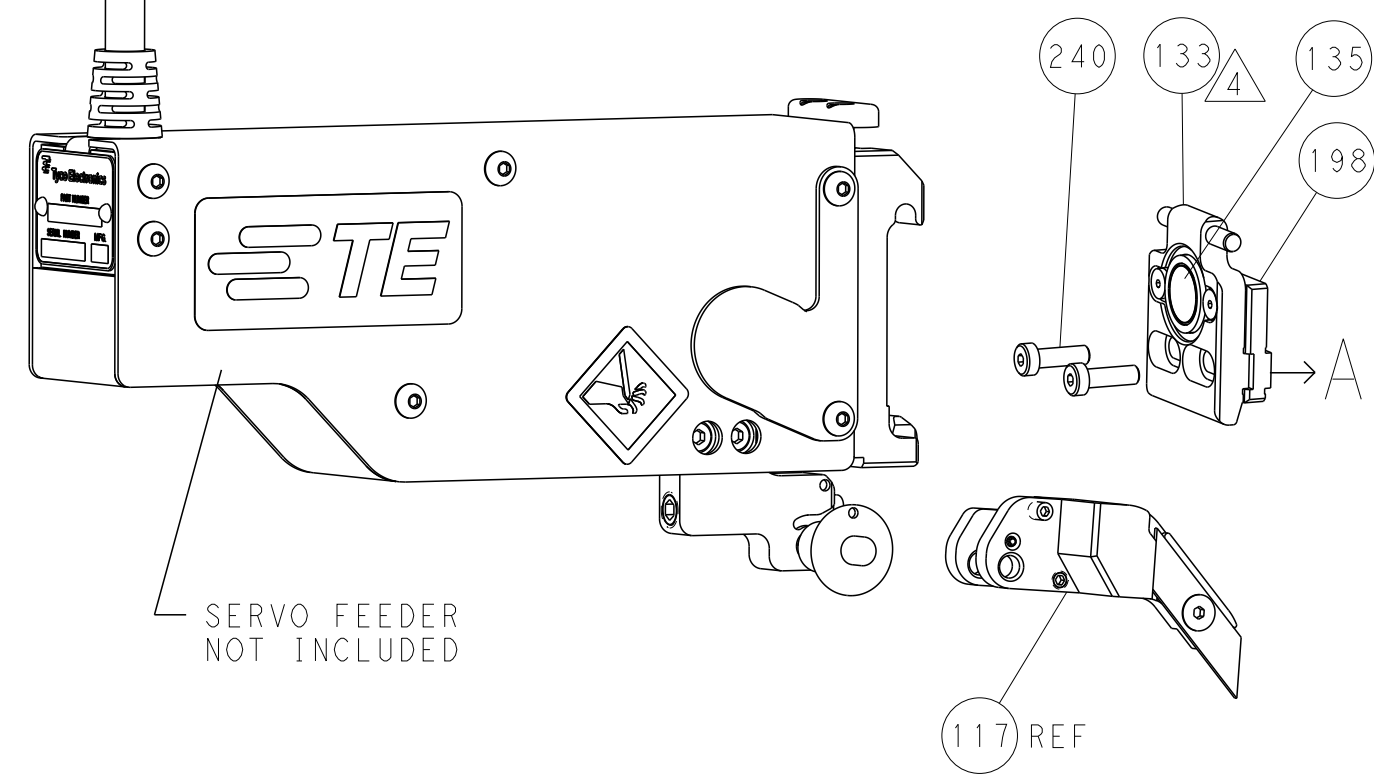

# CAM POSITIONS

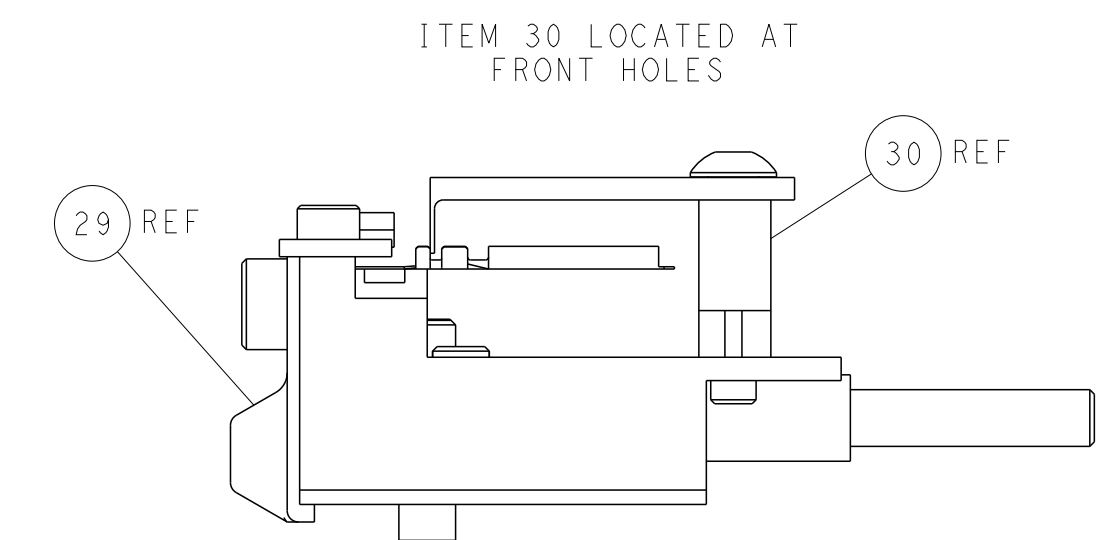
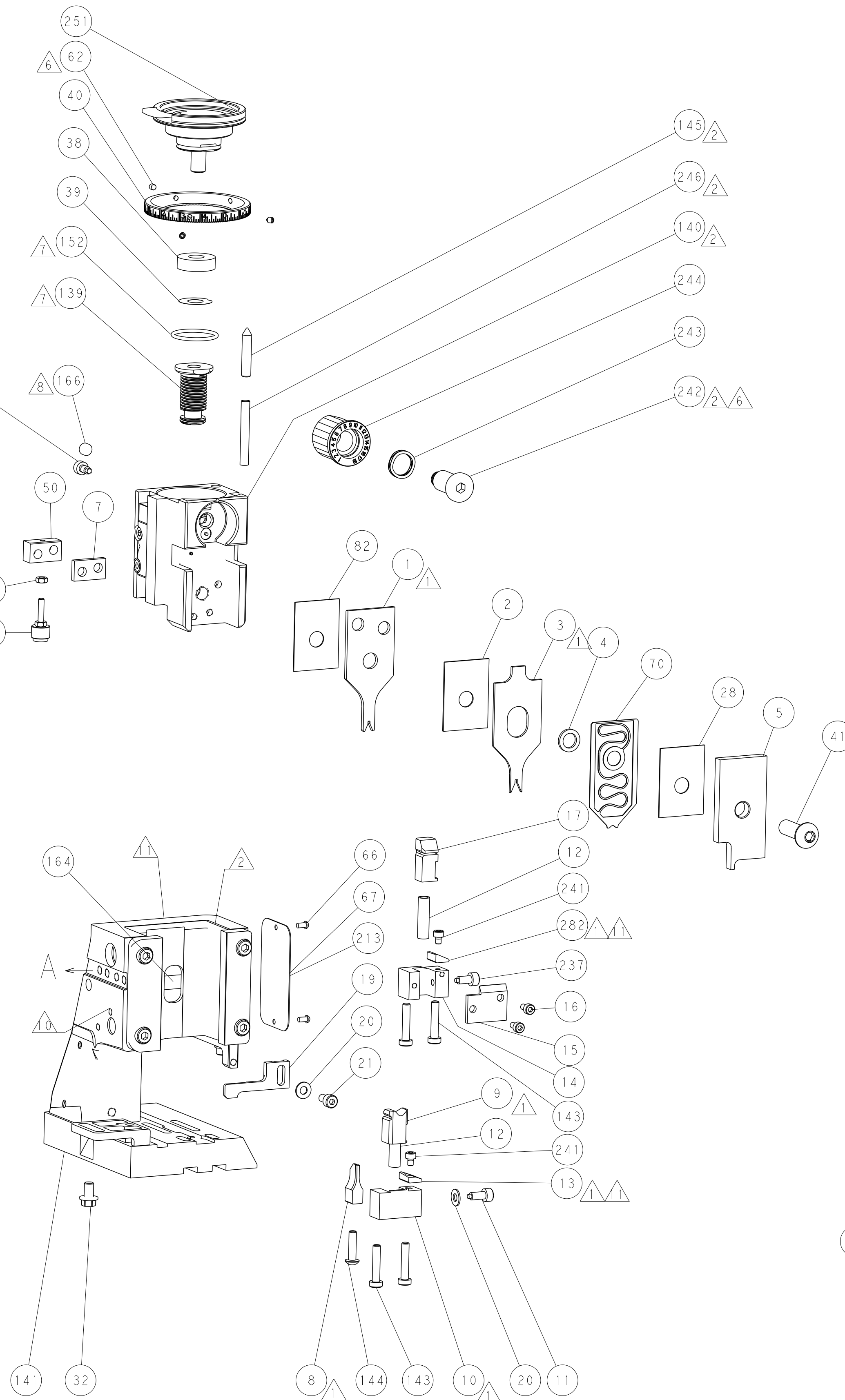
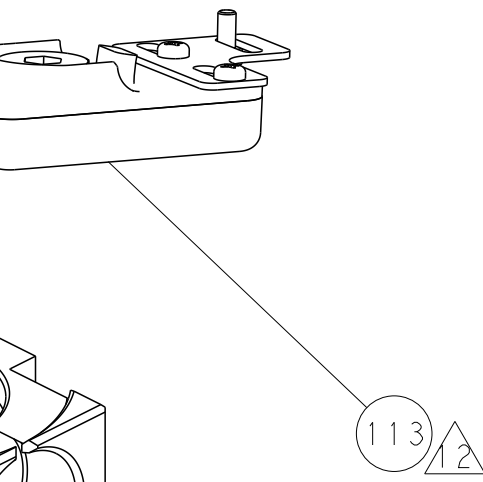
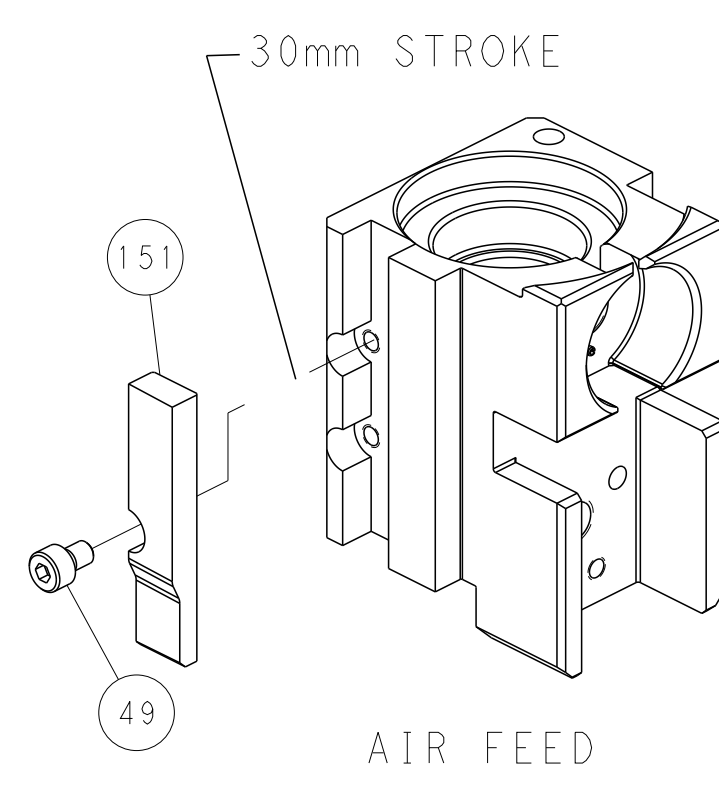
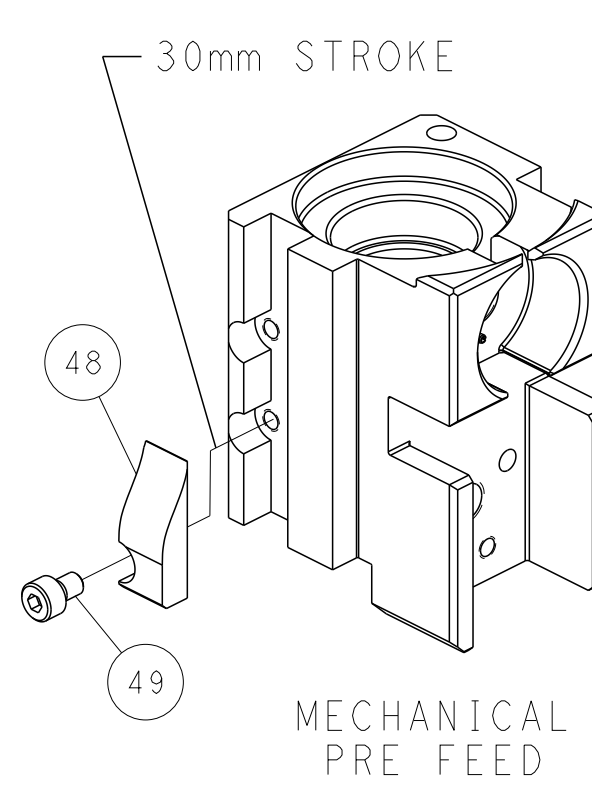
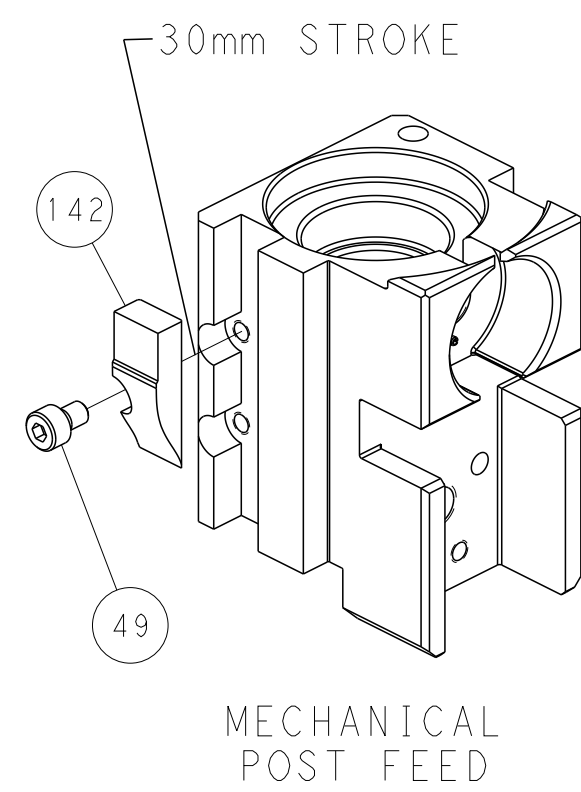

**PACIFIC VERSION**  
 Shown on sheets 3 of 4 & 4 of 4  
 (Atlantic version shown on sheets 1 of 4 & 2 of 4)

DIMENSIONS:		TOLERANCES UNLESS OTHERWISE SPECIFIED:		DWN: H. HUANG 22SEP2014		CHK: L. ZHANG 22SEP2014		APVD: H. GUO 22SEP2014		NAME: Ocean Side Feed Applicator	
mm	0 PLC	±		SIZE	CAGE CODE	DRAWING NO	RESTRICTED TO	STE TE Connectivity Harrisburg, PA 17105-3608			
	1 PLC	±		SCALE	1:2	SHEET 4 OF 4	REV A	Customer Accessible Production Drawing			
	2 PLC	±		MATERIAL: FINISH: WEIGHT: A1 00779 ©=2266492							
	3 PLC	±		Customer Accessible Production Drawing							
	4 PLC	±		SCALE: 1:2 SHEET 4 OF 4 REV A							
	ANGLES	±		SHEETS 1 & 2 ARE NOT REQUIRED FOR PACIFIC VERSION							