

**Standard Range SIAMEZE* Insulation Displacement
Terminals**

1. INTRODUCTION

1.1. Purpose

Testing was performed on Standard Range SIAMEZE* Insulation Displacement Terminals to determine their conformance to the requirements of Product Specification 108-2085, Revision A.

1.2. Scope

This report covers the electrical, mechanical, and environmental performance of the Standard Range SIAMEZE Insulation Displacement Terminals. Testing was performed at the Engineering Assurance Product Testing Laboratory between 13Nov08 and 04Dec09. The test file number for this testing is EA20090930T, additional testing was performed under test file numbers EA20081013T, EA20090857T and EA20090884T. This documentation is on file at and available from the Engineering Assurance Product Testing Laboratory.

1.3. Conclusion

The Standard Range SIAMEZE Insulation Displacement Terminals listed in paragraph 1.5., conformed to the electrical, mechanical, and environmental performance requirements of Product Specification 108-2085 Revision A.

1.4. Test Specimens

Test specimens were representative of normal production lots. Specimens identified with the following part numbers were used for test:

Part Number	Description
4-1601000-1 Wire to Wire	Bobbin 1601486-1 (standard 6/6 Nylon 20% GF) with 2, 4-1601000-1 SIAMEZE terminals connecting 18 AWG copper magnet wire in the bottom contact and 18 AWG stranded lead wire in the top contact secured with 4-1601140-1 Lead Lok
	Bobbin 1601486-1 (standard 6/6 Nylon 20% GF) with 2, 4-1601000-1 SIAMEZE terminals connecting 34 AWG copper magnet wire in the bottom contact and 22 AWG stranded lead wire in the top contact secured with 4-1601140-1 Lead Lok
4-1601009-4 PC Tab Single Barb Terminal	2, 4-1601009-4 terminals with single barbs in a bobbin connecting 18 AWG copper magnet wire
	2, 4-1601009-4 terminals with single barbs in a bobbin connecting 34 AWG copper magnet wire
4-1601039-2 .110 Tab Triple Barb Terminal	2, 4-1601039-2 terminals with triple barbs in a bobbin connecting 18 AWG copper magnet wire
	2, 4-1601039-2 terminals with triple barbs in a bobbin connecting 34 AWG copper magnet wire
1601058-2 .187 Tab Double Barb Terminal	2, 1601058-2 terminals with double barbs in a bobbin connecting 18 AWG copper magnet wire
	2, 1601058-2 terminals with double barbs in a bobbin connecting 34 AWG copper magnet wire

Figure 1

1.5. Environmental Conditions

Unless otherwise stated, the following environmental conditions prevailed during testing:

- Temperature: 15 to 35°C
- Relative Humidity: 25 to 75%

1.6. Test Sequence

Test or Examination	Test Group (a)			
	1	2	3	4
	Test Sequence (b)			
Initial examination of product	1	1	1	1
Low Level Contact Resistance (LLCR)	2,5	2,4		2,4
Current cycling		3		
Retention force			2	
Thermal shock	4			
Humidity/temperature cycling	3			
Temperature life				3
Final examination of product	6	5	3	5

NOTE

- (a) See paragraph 1.4.
- (b) Numbers indicate sequence in which tests are performed.

Figure 2

2. SUMMARY OF TESTING

2.1. Initial Examination of Product - All Test Groups

A Certification of Conformance (C of C) was issued stating that all specimens in this test package were produced, inspected, and accepted as conforming to product drawing requirements, and manufactured using the same core manufacturing processes and technologies as production parts. Where specified, specimens were visually examined and no evidence of physical damage detrimental to product performance was observed.

2.2. LLCR - Test Groups 1, 2 and 4

All LLCR measurements taken at 100 milliamperes maximum and 20 millivolts maximum open circuit voltage were less than 20% increase from Initial measurements.

Condition	Test Group 1			
	18 AWG Magnet Wire With 18 AWG Stranded Wire		34 AWG Magnet Wire With 22 AWG Stranded Wire	
	Initial	Final	Initial	Final
N	15	15	15	15
Minimum	8.39	8.13	187.71	188.84
Maximum	9.35	8.92	189.06	193.79
Mean	8.71	8.44	188.19	190.29
Standard Deviation	0.27	0.24	0.41	1.25
	Test Group 2			
N	15	15	15	15
Minimum	8.57	8.43	189.16	188.80
Maximum	11.05	9.95	191.96	193.74
Mean	9.10	9.01	190.70	190.08
Standard Deviation	0.63	0.47	0.73	1.18
	Test Group 4			
N	15	15	15	15
Minimum	6.54	6.48	183.11	184.80
Maximum	6.91	7.39	185.11	191.97
Mean	6.72	6.83	184.33	186.16
Standard Deviation	0.10	0.28	0.55	1.72

NOTE All values in milliohms.

Figure 3

2.3. Current Cycling - Test Group 2

No evidence of physical damage detrimental to product performance was observed as a result of current cycling.

2.4. Retention Force - Test Group 3

All retention force measurements were greater than 45 N [10 lbf] minimum for single barb, 90 N [20 lbf] minimum for multiple barb and 65 N [15 lbf] minimum for stranded lead wire with Lead Lok (Figure 4).

Condition	18 AWG Magnet Wire 18 AWG Stranded Wire	34 AWG Magnet Wire 22 AWG Stranded Wire	18 AWG Magnet Wire	34 AWG Magnet Wire
	Wire-to-Wire	Wire-to-Wire	Single Barb	Single Barb
N	30	30	30	30
Minimum	79.04 [17.77]	87.94 [19.77]	86.52 [19.45]	82.20 [18.48]
Maximum	113.07 [25.42]	112.14 [25.21]	116.32 [26.15]	100.57 [22.61]
Mean	94.26 [21.19]	99.20 [22.30]	98.08 [22.05]	89.99 [20.23]
Standard Deviation	8.85 [1.99]	7.03 [1.58]	5.96 [1.34]	3.96 [0.89]
Condition	18 AWG Magnet Wire	34 AWG Magnet Wire	18 AWG Magnet Wire	34 AWG Magnet Wire
	Triple Barb	Triple Barb	Double Barb	Double Barb
N	30	30	30	30
Minimum	110.76 [24.90]	109.43 [24.60]	124.51 [27.99]	116.90 [26.28]
Maximum	145.72 [32.76]	155.11 [34.87]	142.65 [32.07]	146.52 [32.94]
Mean	128.46 [28.88]	135.27 [30.41]	134.47 [30.23]	125.75 [28.27]
Standard Deviation	10.90 [2.45]	13.97 [3.14]	4.27 [0.96]	6.23 [1.40]

NOTE All values in N [lbf].

Figure 4

2.5. Thermal Shock - Test Group 1

No evidence of physical damage was visible as a result of thermal shock testing.

2.6. Humidity/temperature Cycling - Test Group 1

No evidence of physical damage was visible as a result of humidity/temperature cycling.

2.7. Temperature Life - Test Group 4

No evidence of physical damage was visible as a result of temperature life testing.

2.8. Final Examination of Product - All Test Groups

Specimens were visually examined and no evidence of physical damage detrimental to product performance was observed.

3. TEST METHODS

3.1. Initial Examination of Product

Where specified, specimens were visually examined for evidence of physical damage detrimental to product performance.

3.2. LLCR

LLCR measurements were made using a 4 terminal measuring technique. The test current was maintained at 100 milliamperes with a 20 millivolt maximum open circuit voltage (Figure 5).

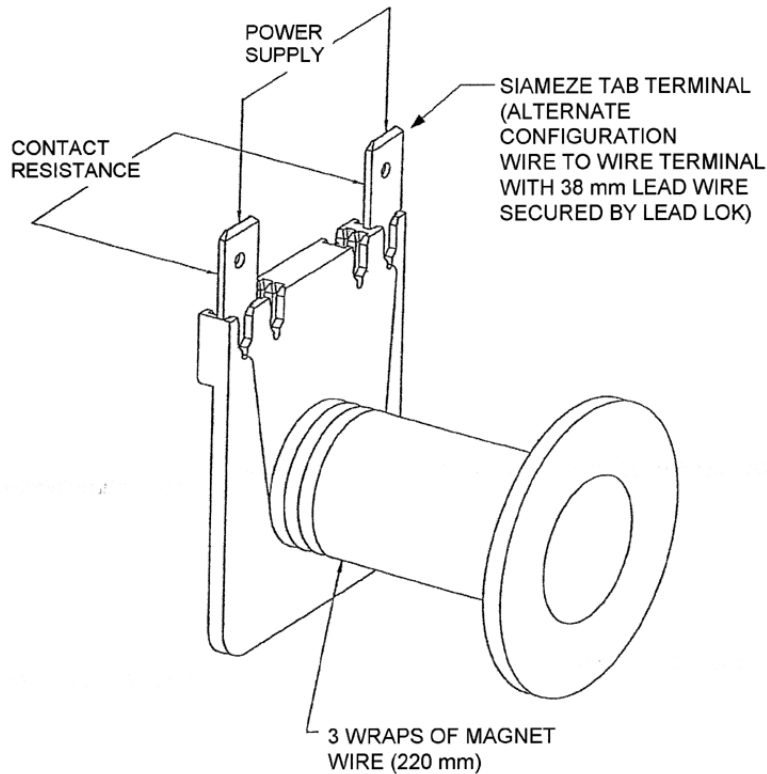

Figure 5
LLCR Test Configuration

3.3. Current Cycling

Specimens connected in a series circuit were subjected to 100% of rated current for 250 cycles consisting of current ON for 15 minutes and current OFF for 15 minutes.

3.4. Contact Retention

The force necessary to dislodge the terminal was measured using a tensile/compression device with a free floating fixture and a rate of travel of 25.4 mm [1 in] per minute.

3.5. Thermal Shock

Specimens were subjected to 25 cycles of thermal shock with each cycle consisting of 30 minute dwells at -40 and 125°C with 1 minute transition between temperatures.

3.6. Humidity/temperature Cycling

Specimens were exposed to 10 cycles of humidity/temperature cycling. Each cycle lasted 24 hours and consisted of cycling the temperature between 25 and 65°C twice while maintaining high humidity.

3.7. Temperature Life

Specimens were subjected to a temperature of 118°C for 33 days (792 hours).

3.8. Final Examination of Product

Specimens were visually examined for evidence of physical damage detrimental to product performance.