

# Female Style C Crimp

Series 8464 – 3 rows (3 x 32)

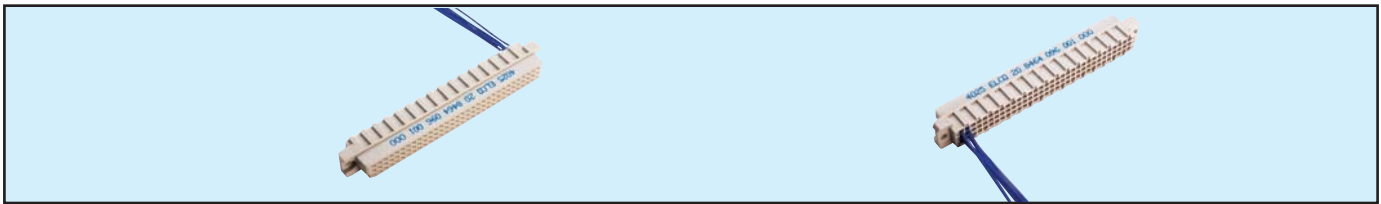

Contact Design	Number of Contacts	Loading Description	Part Number
Crimp	96	Insulator without keying	20 8464 096 001 000
	96	Insulator with keying	22 8464 096 001 000
		Contacts for 8464 on 10K reel	60 8464 0213 99 742
		Loose contacts for 8464	60 8464 0213 00 742
Tools		Hand tool (with insert)	06 8464 0101 00 000
		Crimping machine including applicator	06 7865 5200 00 000
		Extraction tool	06 8464 8101 00 000

## DIMENSIONS

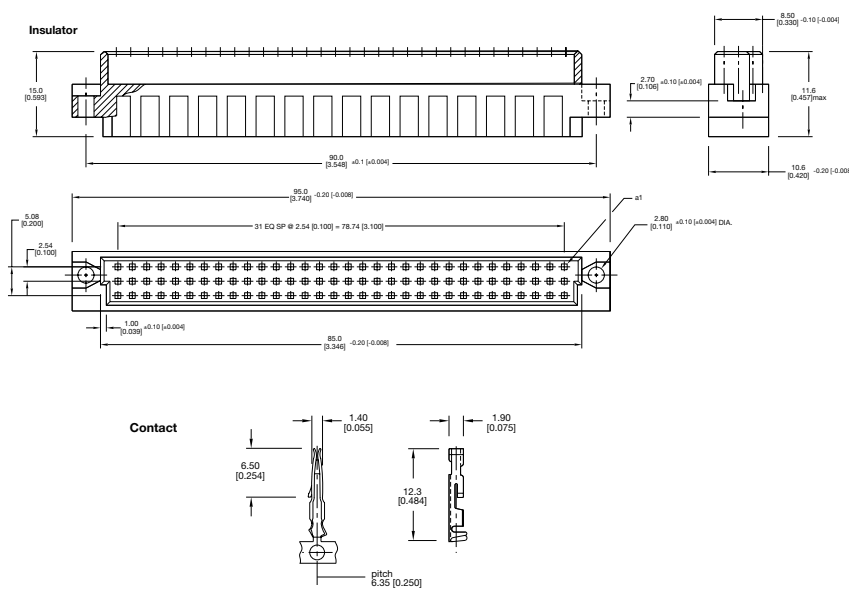

AVX 3-row, 96 contact position receptacle connector with crimp contacts follows the pattern of the DIN 41612 standard. The innovative contact principle assures reliable electrical connection even under extreme conditions.

The crimps are individually terminated and inserted into the housing. With the use of an extraction tool, the contact can be removed from the housing for inspection or repair.

Main applications are as an input/output connector on backpanels or rack frontside.

A complete tool program is available, from hand crimp to automatic crimping machines.

## TECHNICAL DATA

Operating Current	1.5 amp max.
Operation Voltage	300 V/AC/470 V/DC
Contact Resistance	≤ 15Ω
Dielectric Resistance	≥ 1012Ω
Insulation Material	Polyester 94 V-0 UL
Contact Material	Cu-alloy
Plating	Performance Class III
Crimp AWG Range	24 - 28
Grid Spacing	0.100 (2.54)