

LOC		DIST		REVISIONS			
P	LTN	DESCRIPTION	DATE	DWN	APVD		
G		REVISED PER ECO-15-005484	28JULY2015	SC	DZ		

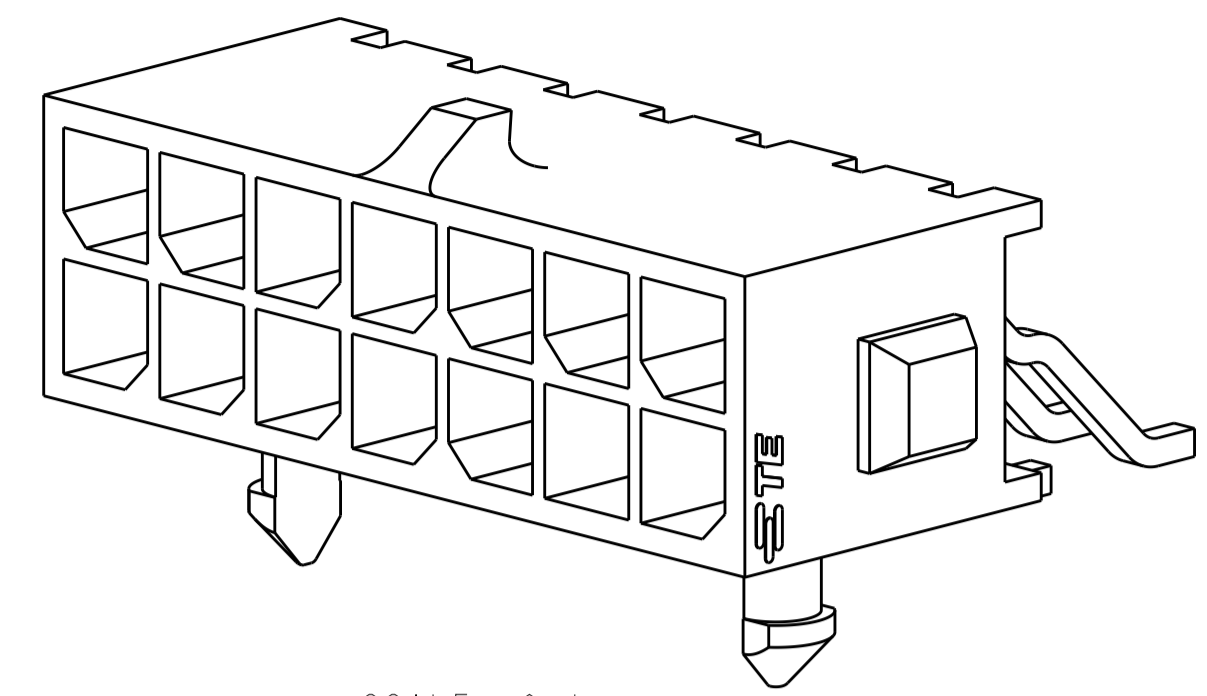

SCALE 6:1

- 1 MATERIAL:
CONTACTS - BRASS.
HOUSING - UL 94V-0 RATED HIGH TEMP NYLON, COLOR; BLACK.
- 2 FINISH:
CONTACTS - 2.54µm MINIMUM TIN-LEAD OVER 1.27µm MINIMUM NICKEL.
- 3 DIMENSION APPLIES TO SOLDERTAIL SURFACES AND STANDOFF SURFACES.
- 4 RECOMMENDED PCB BOARD THICKNESS OF 1.57.
- 5 ALL SOLDERTAILS.
- 6 FINISH:
CONTACTS - 2.54µm MINIMUM MATTE TIN OVER 1.27µm MINIMUM NICKEL.

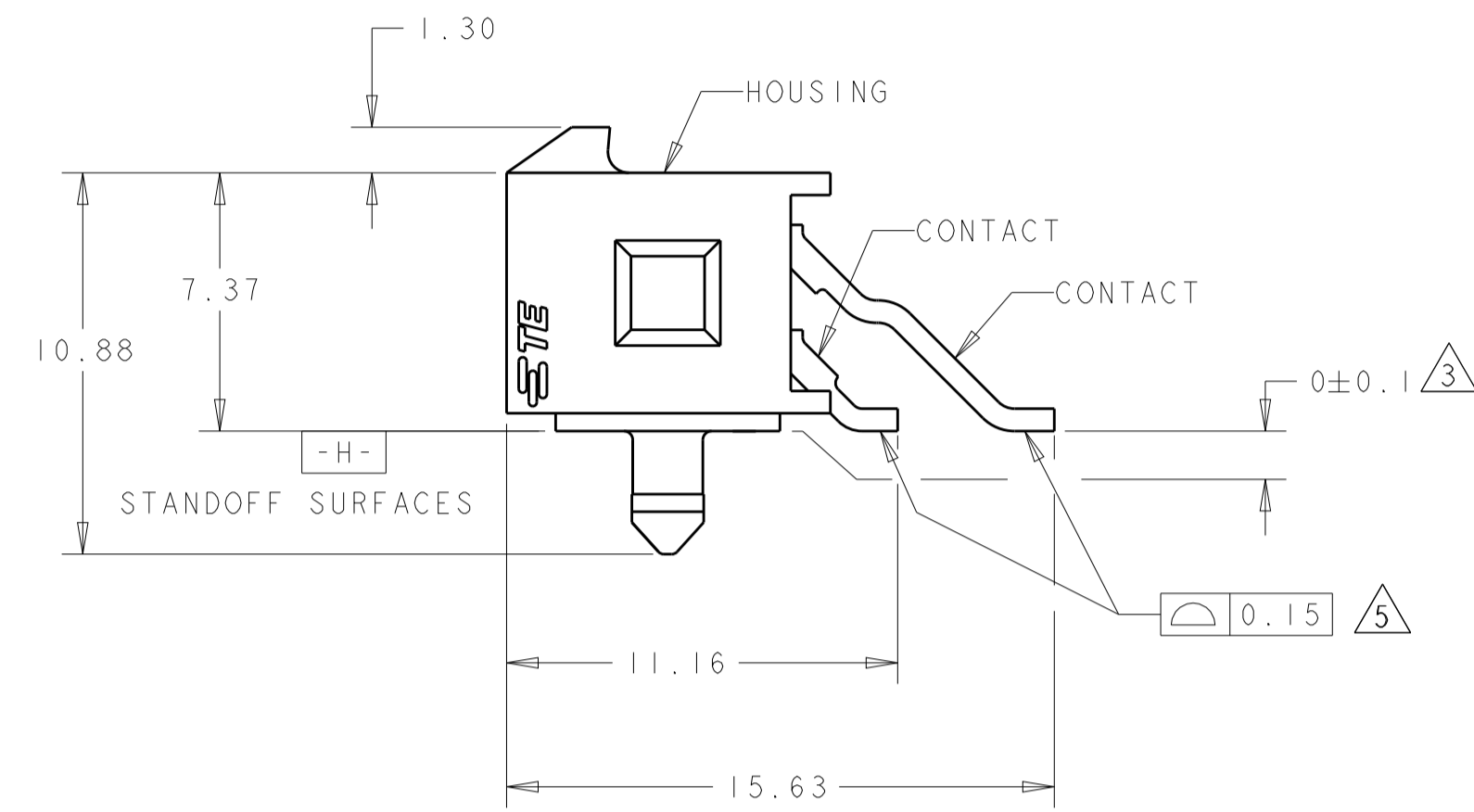
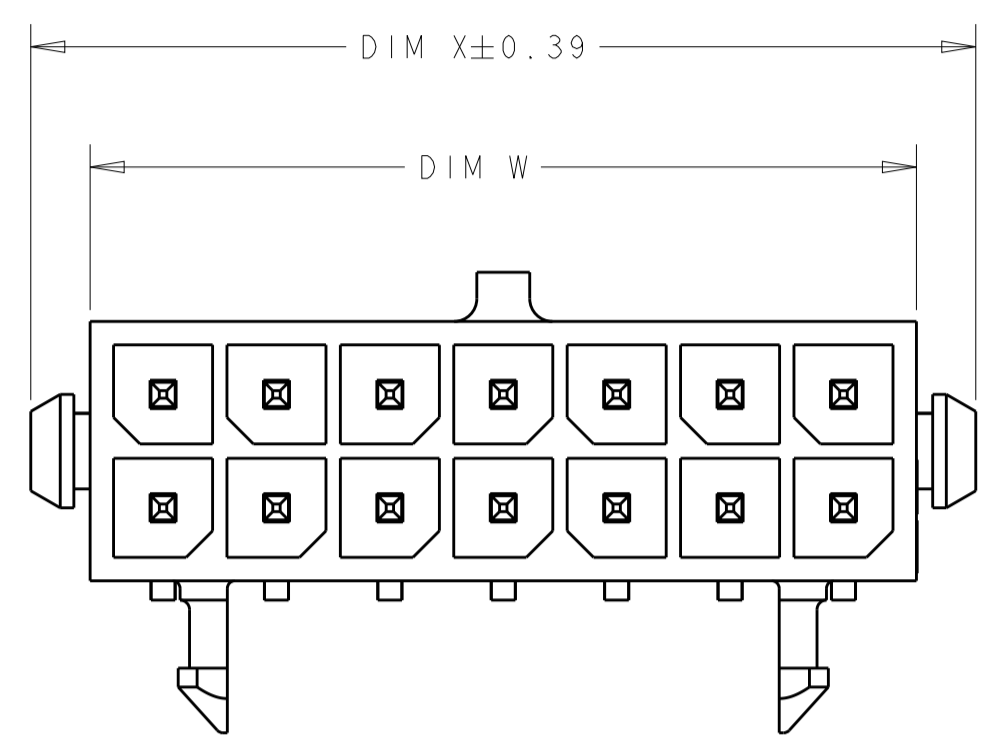
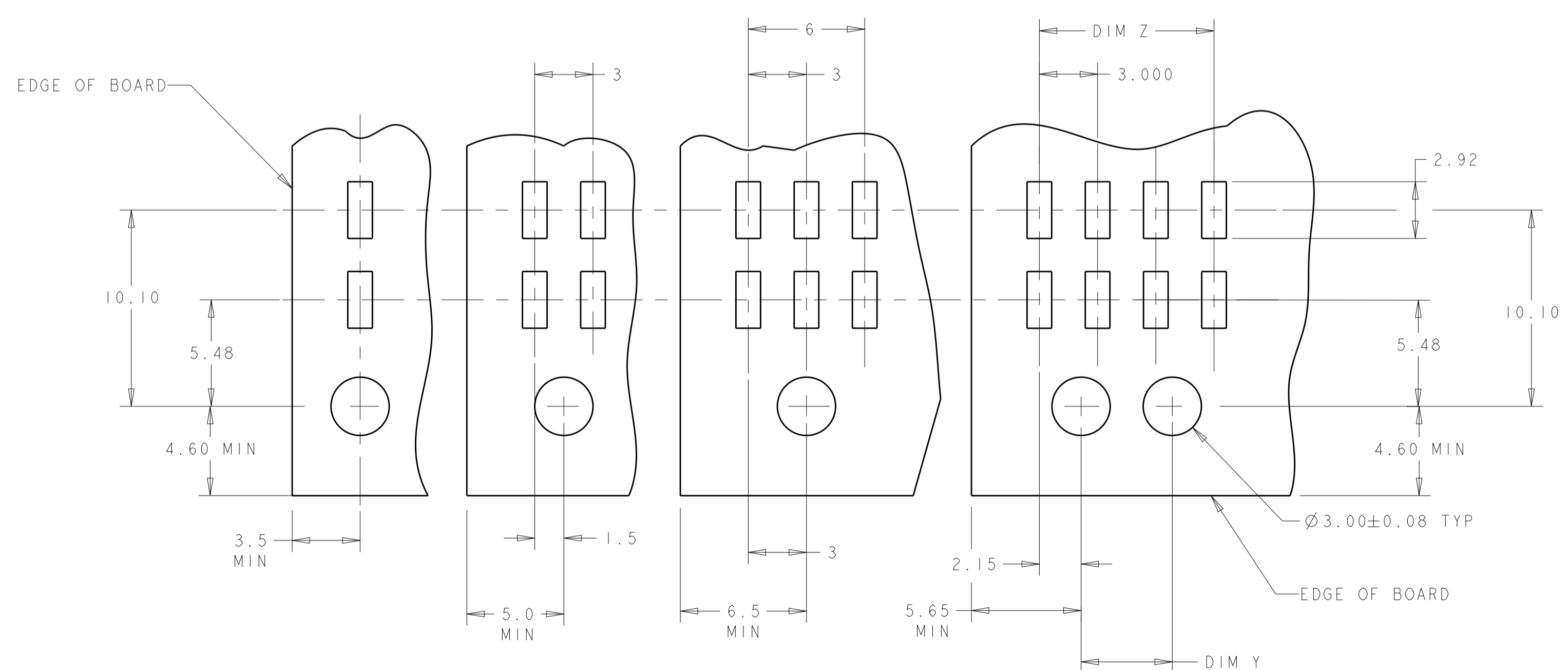
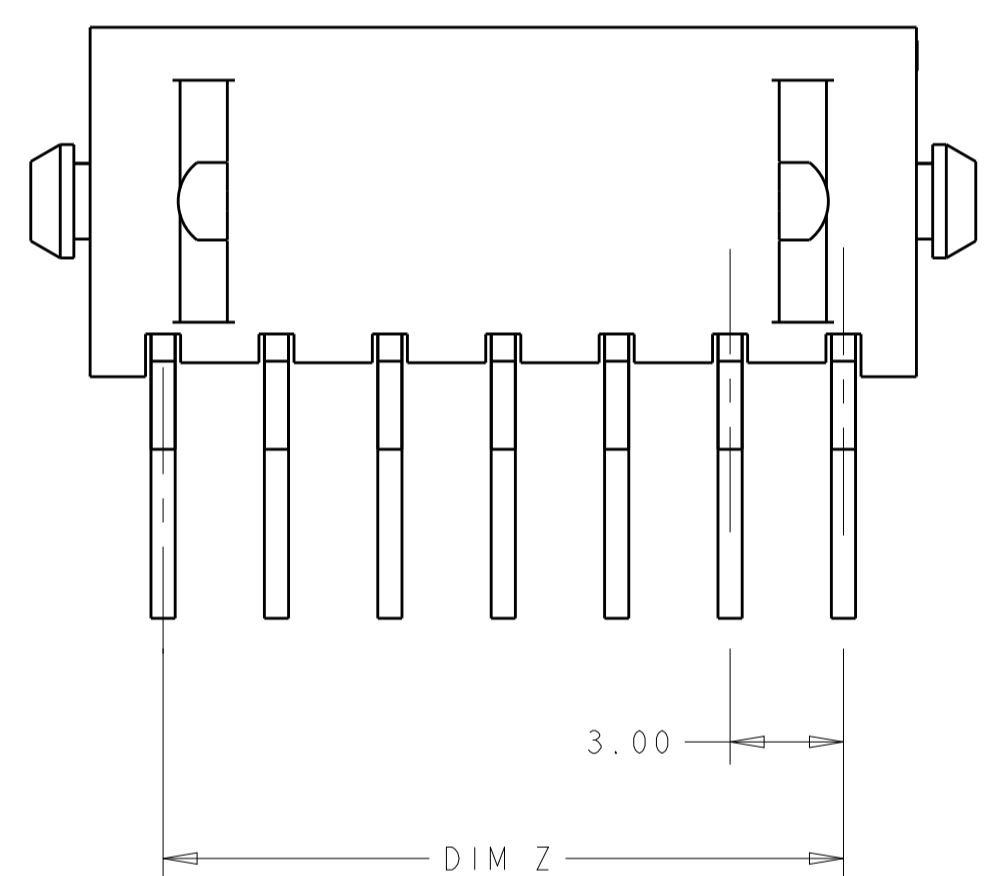

RECOMMENDED PCB LAYOUT (COMPONENT SIDE) 4

FINISH	DIM Y	DIM W	DIM Z	DIM X	NO. OF POSN.	PART NUMBER
6	36.86	28.70	33.00	40.00	24	5-794621-4
6	33.86	25.70	30.00	37.00	22	5-794621-2
6	30.86	22.70	27.00	34.00	20	5-794621-0
6	27.86	19.70	24.00	31.00	18	4-794621-8
6	24.86	16.70	21.00	28.00	16	4-794621-6
6	21.86	13.70	18.00	25.00	14	4-794621-4
6	18.86	10.70	15.00	22.00	12	4-794621-2
6	15.86	7.70	12.00	19.00	10	4-794621-0
6	12.86	4.70	9.00	16.00	8	3-794621-8
6	9.86	-	6.00	13.00	6	3-794621-6
6	6.86	-	3.00	10.00	4	3-794621-4
6	3.86	-	-	7.00	2	3-794621-2
2	36.86	28.70	33.00	40.00	24	2-794621-4
2	33.86	25.70	30.00	37.00	22	2-794621-2
2	30.86	22.70	27.00	34.00	20	2-794621-0
2	27.86	19.70	24.00	31.00	18	1-794621-8
2	24.86	16.70	21.00	28.00	16	1-794621-6
2	21.86	13.70	18.00	25.00	14	1-794621-4
2	18.86	10.70	15.00	22.00	12	1-794621-2
2	15.86	7.70	12.00	19.00	10	1-794621-0
2	12.86	4.70	9.00	16.00	8	794621-8
2	9.86	-	6.00	13.00	6	794621-6
2	6.86	-	3.00	10.00	4	794621-4
2	3.86	-	-	7.00	2	794621-2

THIS DRAWING IS A CONTROLLED DOCUMENT. DWN S. HOOVER 23-MAR-2005
 CHK C. JONES 23-MAR-2005
 APVD C. JONES 23-MAR-2005

STE TE Connectivity

ASSEMBLY, SURFACE MOUNT, R/A, TIN HEADER, PLASTIC BOARDLOCK, MICRO MATE-N-LOK(TM)

SIZE CAGE CODE DRAWING NO RESTRICTED TO
 A100779C=794621

SCALE 5:1 SHEET 1 OF 1 REV G

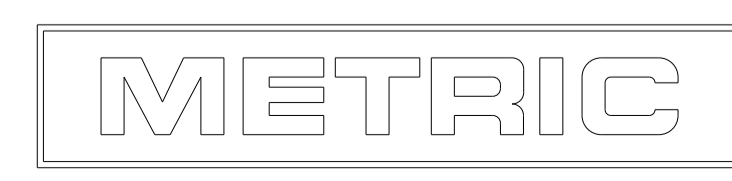

Mouser Electronics

Authorized Distributor

Click to View Pricing, Inventory, Delivery & Lifecycle Information:

[TE Connectivity:](#)

[2-794621-4](#)