

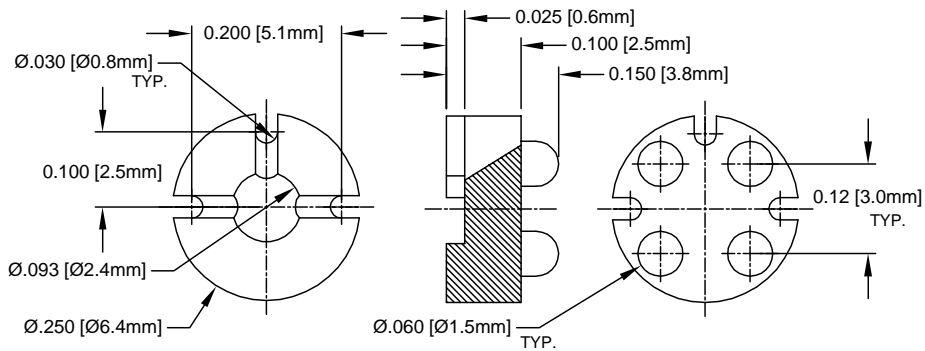

REV.	DESCRIPTION	DATE	APPROVED
C	Engineering Update w/o Changes	03/03/04	M. C.



3. MATERIAL: NYLON 6/6, 94V-2, WHITE. BIVAR MATERIAL CODE 04-WE.  
BASF ULTRAMID NYLON 6/6 A3K WHITE.
2. MATERIAL: NYLON 6/6, 94V-2, NATURAL. BIVAR MATERIAL CODE 03-NL.  
BASF ULTRAMID NYLON 6/6 A3K NATURAL.
1. GENERAL SPECIFICATIONS: BIVAR MOLDED COMPONENT SPECIFICATION BV00-E101.

STANDARD TOLERANCE (UNLESS OTHERWISE SPECIFIED)		 4 THOMAS, IRVINE, CA. 92618 TEL: (949) 951-8808 FAX: (949) 951-3974			
DECIMALS	ANGULAR				
.X ± .1	X° ± 1°	<b>TITLE:</b> PERM-O-PAD TO-18 MOUNT			
.XX ± .01					
.XXX ± .005		<b>DESIGNED:</b> Anthony Vilgiate	<b>DATE:</b> 11/15/96	<b>PART NO:</b> 202-150	<b>REVISION:</b> C
<b>CHECKED:</b> M. Chen		<b>DATE:</b> 11/13/03	<b>CAGE CODE :</b> 32559   <b>SHEET #</b> 1 OF 1		
CAD GENERATED DOCUMENT. DO NOT MEASURE DRAWING.					