

Electronic housing - EMG125-LG - 2947983

Please be informed that the data shown in this PDF Document is generated from our Online Catalog. Please find the complete data in the user's documentation. Our General Terms of Use for Downloads are valid (<http://phoenixcontact.com/download>)



Electronic housing, for PCB insertion, without screw connection terminal blocks and cover

Product Features

- Choice of four cover sizes in transparent or color versions
- Practical and easy-to-wire conductor connections
- User-friendly and safe mounting on DIN rails according to EN 60715
- High degree of flexibility due to the wide choice of versions
- Uniform and appropriate housing technology
- Space-saving accommodation of electronic components in finely graded module versions available with 10 to 150 mm pitch
- Inflammability class V0 insulation material (according to UL 94)
- Shock and contamination-proof accommodation of electronic components
- Universal PCBs for all pitches



Key Commercial Data

Packing unit	1 pc
Minimum order quantity	2 pc
Weight per Piece (excluding packing)	100.85 g
Custom tariff number	85472000
Country of origin	Germany

Technical data

General

Housing type	Component housing
Housing material	Polycarbonate fiber reinforced
Color	green

Ambient conditions

Electronic housing - EMG125-LG - 2947983

Technical data

Ambient conditions

Ambient temperature (operation)	-40 °C ... 125 °C
---------------------------------	-------------------

Dimensions

Length	75 mm
Constructional height	47.5 mm
Width	125 mm
Pitch	5 mm

Technical data

Flammability rating according to UL 94	V0
Power dissipation without gap	9.5 W
Power dissipation with 20 mm gap	11 W
Number of positions	48

Connection data

Conductor cross section solid min.	0.2 mm ²
Conductor cross section solid max.	4 mm ²
Conductor cross section flexible min.	0.2 mm ²
Conductor cross section flexible max.	2.5 mm ²
Conductor cross section AWG min.	24
Conductor cross section AWG max.	12
Stripping length	8 mm

Standards and Regulations

Flammability rating according to UL 94	V0
----------------------------------------	----

Classifications

eCl@ss

eCl@ss 4.0	27180401
eCl@ss 4.1	27180401
eCl@ss 5.0	27180506
eCl@ss 5.1	27180506
eCl@ss 6.0	27180802
eCl@ss 7.0	27182702
eCl@ss 8.0	27182702
eCl@ss 9.0	27182702

ETIM

ETIM 2.0	EC001031
----------	----------

Electronic housing - EMG125-LG - 2947983

Classifications

ETIM

ETIM 3.0	EC001031
ETIM 4.0	EC001031
ETIM 5.0	EC001031

UNSPSC

UNSPSC 6.01	31261501
UNSPSC 7.0901	31261501
UNSPSC 11	31261501
UNSPSC 12.01	31261501
UNSPSC 13.2	31261501

Approvals

Approvals

Approvals

EAC

Ex Approvals

Approvals submitted

Approval details

EAC

Accessories

Accessories

Device marking

Marking material - EMG-GKS 22 - 2941594



Equipment marker tag, width 22 mm

Electronic housing - EMG125-LG - 2947983

Accessories

Marking material - EMG-GKS 22 - 2941594



Equipment marker tag, width 22 mm

PCB

Electronic housing - P 1-EMG125 - 2946010



PCB for assembling electronic components

Marking material - EMG-GKS 12 - 2947035



Equipment marker, width 12 mm

Marking material - EMG-GKS 12 - 2947035



Equipment marker, width 12 mm

Required add-on products

Electronic housing - EMG125-LG - 2947983

Accessories

Covering hood - EMG125-H 7,5MM KLAR - 2943194



Covering hood, for the contact and dust-protected encapsulation of the components, in transparent design. Height: 7.5 mm

Electronic housing - EMG125-H 15MM KLAR - 2943181



Covering hood, for the contact and dust-protected encapsulation of the components, in transparent design. Height: 15 mm, width: 125 mm

Electronic housing - EMG125-H 52MM GN - 2943518



Covering hood, for the contact and dust-protected encapsulation of the components, in green design. Height: 52 mm, width: 125 mm

Drawings

Dimensional drawing

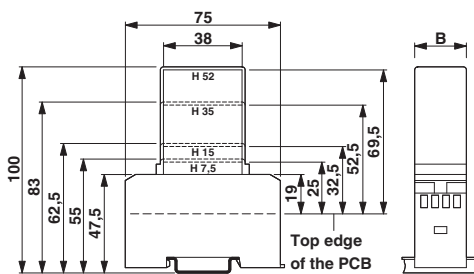

Dimensional drawing

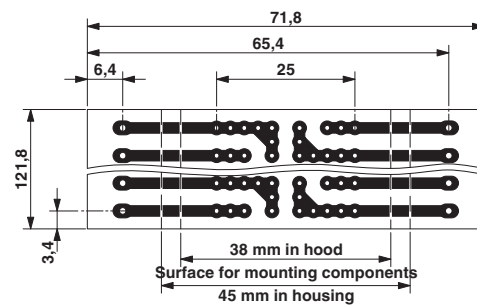

1 = Top edge of the PCB
B = Housing width

Pitch 5 mm
a = Area for mounting components, 38 mm in the hood
b = Area for mounting components, 45 mm in the housing

Mouser Electronics

Authorized Distributor

Click to View Pricing, Inventory, Delivery & Lifecycle Information:

[Phoenix Contact:](#)

[2947983](#)