

## Electronic housing - UEGM 22,5 BK OHNE LOGO - 2792882

Please be informed that the data shown in this PDF Document is generated from our Online Catalog. Please find the complete data in the user's documentation. Our General Terms of Use for Downloads are valid (<http://phoenixcontact.com/download>)

Electronic housing, for PCB insertion, fully equipped with 3 screw or 6 tab connections per side



### Key Commercial Data

Packing unit	1 STK
Minimum order quantity	10 STK
GTIN	 4 017918 243050
GTIN	4017918243050
Weight per Piece (excluding packing)	52.330 g
Custom tariff number	85369010
Country of origin	Germany

### Technical data

#### Standards and Regulations

Flammability rating according to UL 94	V2
--	----

#### Environmental Product Compliance

China RoHS	Environmentally Friendly Use Period = 50
	For details about hazardous substances go to tab "Downloads", Category "Manufacturer's declaration"

### Drawings

# Electronic housing - UEGM 22,5 BK OHNE LOGO - 2792882

Explosion drawing

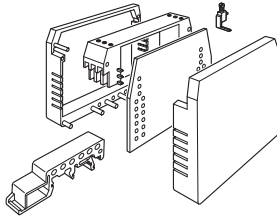

Dimensional drawing

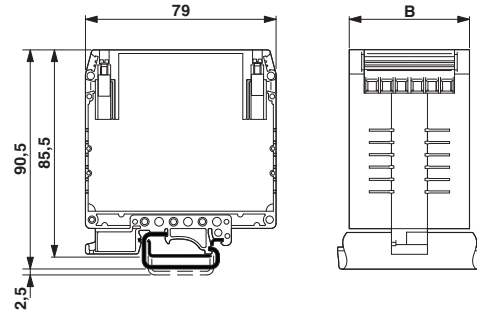

Dimensional drawing

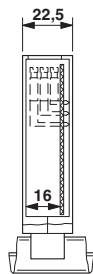

Dimensional drawing

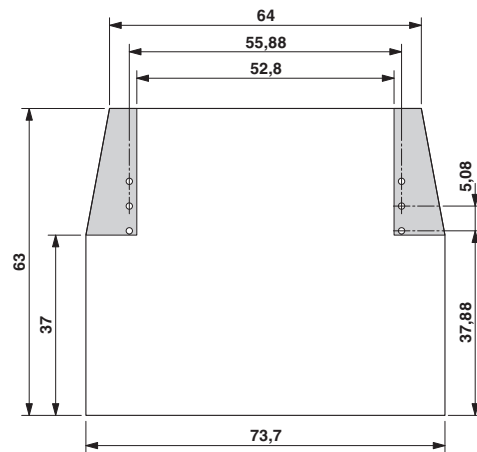

UEGM 22,5... with 1 PCB, 6 positions or 12 positions (FS/FS)

Schematic diagram

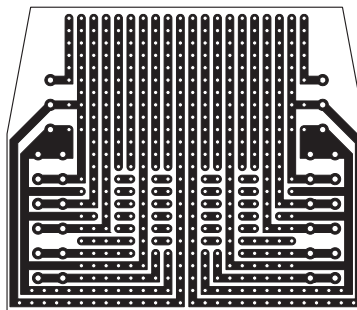

# Electronic housing - UEGM 22,5 BK OHNE LOGO - 2792882

## Classifications

### eCl@ss

eCl@ss 4.0	27180401
eCl@ss 4.1	27180401
eCl@ss 5.0	27180506
eCl@ss 5.1	27180506
eCl@ss 6.0	27180802
eCl@ss 7.0	27182702
eCl@ss 8.0	27182702
eCl@ss 9.0	27182702

### ETIM

ETIM 2.0	EC001031
ETIM 3.0	EC001031
ETIM 4.0	EC001031
ETIM 5.0	EC001031
ETIM 6.0	EC001031

### UNSPSC

UNSPSC 6.01	31261501
UNSPSC 7.0901	31261501
UNSPSC 11	31261501
UNSPSC 12.01	31261501
UNSPSC 13.2	31261501

## Approvals

### Approvals

---

#### Approvals

UL Recognized / EAC

---

#### Ex Approvals

---

### Approval details

UL Recognized		<a href="http://database.ul.com/cgi-bin/XYV/template/LISEXT/1FRAME/index.htm">http://database.ul.com/cgi-bin/XYV/template/LISEXT/1FRAME/index.htm</a>	FILE E 240868
---------------	---	---	---------------

## Electronic housing - UEGM 22,5 BK OHNE LOGO - 2792882

### Approvals

EAC		EAC-Zulassung
-----	---	---------------

### Accessories

#### Accessories

#### Bridge

Wire bridge - DB 50- 90 BK - 2820916

Wire bridge, Color: black



---

Wire bridge - DB 50- 90 GY - 2820929

Wire bridge, Color: gray



# Mouser Electronics

Authorized Distributor

Click to View Pricing, Inventory, Delivery & Lifecycle Information:

[Phoenix Contact:](#)

[2792882](#)