

## CM 75-LG/H 35/BO BK

Order No.: 2942881

The illustration shows versions CM 50-LG/H 30/BO and CM 75-LG/H 35 BO



<http://eshop.phoenixcontact.de/phoenix/treeViewClick.do?UID=2942881>

Electronic module, for PCB insertion, with a high 35 mm covering hood

### Commercial data

GTIN (EAN)	 4 017918 126384
sales group	F030
Pack	5 pcs.
Customs tariff	85369010
Catalog page information	Page 634 (CC-2011)

### Product notes

WEEE/RoHS-compliant since:  
08/06/2004



<http://www.download.phoenixcontact.com>  
Please note that the data given here has been taken from the online catalog. For comprehensive information and data, please refer to the user documentation. The General Terms and Conditions of Use apply to Internet downloads.

### Technical data

#### General

Housing type	Complete housing
Housing material	Polycarbonate fiber reinforced
Color	black

#### Dimensions / positions

Length	102 mm
--------	--------

Width	75 mm
<b>Technical data</b>	
Ambient temperature (operation)	-40 °C ... 125 °C
Inflammability class acc. to UL 94	V0
Power dissipation at 20°C in the horizontal mounting position	40.3 W 52.5 W

**Diagrams/Drawings**

Dimensioned drawing

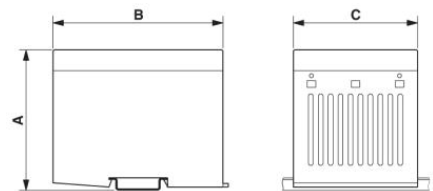

Dimension A=108 mm; dimension B=102 mm; dimension C=75 mm

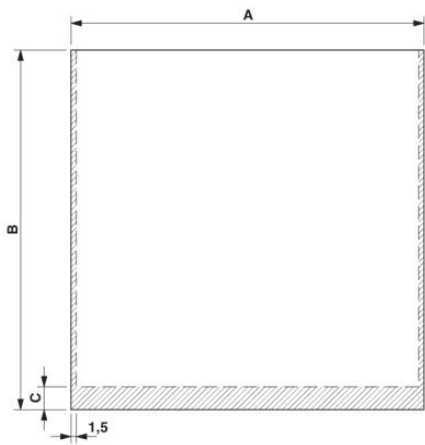

PCB 1, 7: Dimension A: 72.5 mm; B: 96.0 mm; C: 6.5 mm  
 PCB 8, 13: Dimension A: 100.0 mm; B: 96.0 mm; C: 6.5 mm

Schematic diagram

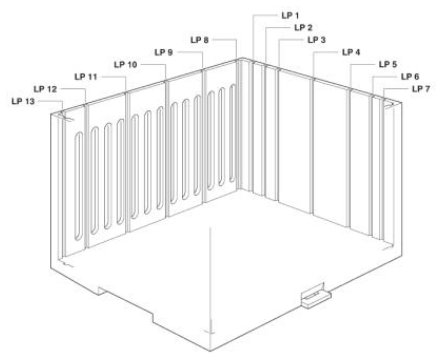

**Address**

PHOENIX CONTACT Inc., USA  
586 Fulling Mill Road  
Middletown, PA 17057, USA  
Phone (800) 888-7388  
Fax (717) 944-1625  
<http://www.phoenixcon.com>



© 2011 Phoenix Contact  
Technical modifications reserved;