

2N7002-HF (N-Channel)

RoHS Device
Halogen Free



Features

-Power dissipation : 0.35W

Equivalent Circuit

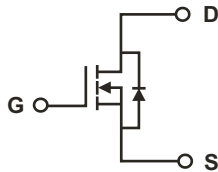

G : Gate
S : Source
D : Drain

Maximum Ratings (at TA=25°C)

Parameter	Symbol	Value	Unit
Drain-Source voltage	V_{DS}	60	V
Drain current	I_D	250	mA
Power dissipation	P_D	350	mW
Junction and storage temperature	T_J, T_{STG}	-55 ~ +150	°C

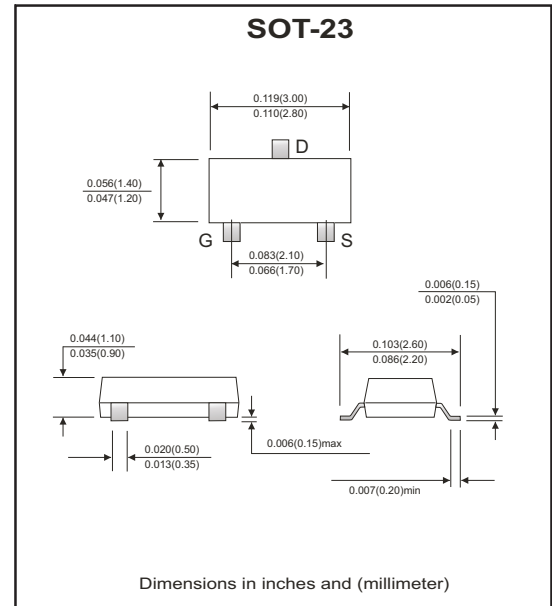

Electrical Characteristics (at TA=25°C unless otherwise noted)

Parameter	Conditions	Symbol	Min	Typ	Max	Unit
Drain-Source breakdown voltage	$V_{GS}=0V, I_D=10\mu A$	$V_{(BR)DSS}$	60	70		V
Gate-Threshold voltage	$V_{DS}=V_{GS}, I_D=250\mu A$	$V_{th(GS)}$	1	1.5	2.5	
Gate-body leakage	$V_{DS}=0V, V_{GS}=15V$	I_{GSS}			10	nA
Zero gate voltage drain current	$V_{DS}=60V, V_{GS}=0V$	I_{DSS}			1	μA
	$V_{DS}=60V, V_{GS}=0V, T_J=125^\circ C$				500	
On-state drain current	$V_{GS}=10V, V_{DS}=7.5V$	$I_{D(ON)}$	800	1300		mA
	$V_{GS}=4.5V, V_{DS}=10V$		500	700		
Drain-Source on resistance	$V_{GS}=10V, I_D=250mA$	$r_{DS(ON)}$		1.5	3	Ω
	$V_{GS}=4.5V, I_D=200mA$			2.0	4	
Forward tran conductance	$V_{DS}=15V, I_D=200mA$	g_{fs}		300		mS
Diode forward voltage	$I_S=200mA, V_{GS}=0V$	V_{SD}		0.85	1.2	V
Total gate charge	$V_{DS}=30V, V_{GS}=10V, I_D=250mA$	Q_g		0.6	1.0	nC
Gate-Source charge		Q_{gs}		0.06		
Gate-Drain charge		Q_{gd}		0.06		
Input capacitance	$V_{DS}=25V, V_{GS}=0V, f=1MHz$	C_{iss}		25		pF
Output capacitance		C_{oss}		6		
Reverse transfer capacitance		C_{rss}		1.2		
Turn-on time	$V_{DD}=30V, R_L=200\Omega$ $I_D=100mA, V_{GEN}=10V$ $R_G=10\Omega$	$t_{d(ON)}$		7.5	20	nS
		t_r		6		
Turn-off time		$t_{d(off)}$		7.5	20	

RATING AND CHARACTERISTIC CURVES (2N7002-HF)

Fig.1 On-Region Characteristics

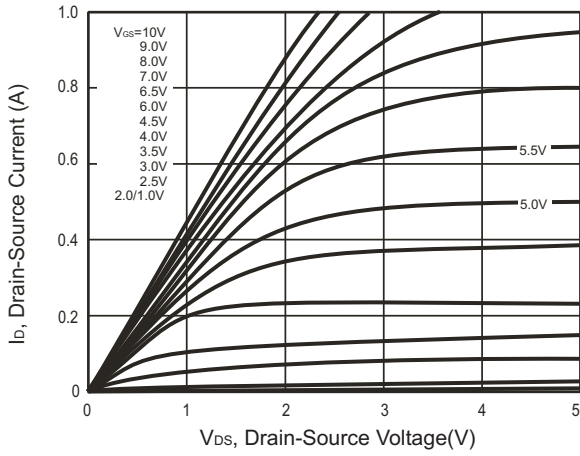

Fig.2 On-Resistance vs Drain Current

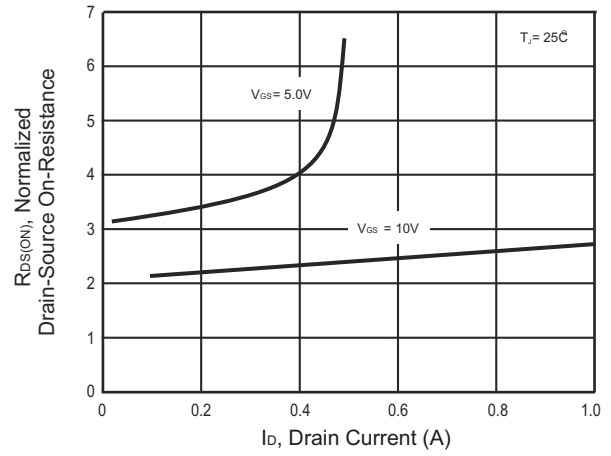

Fig.3 On-Resistance vs Junction Temperature

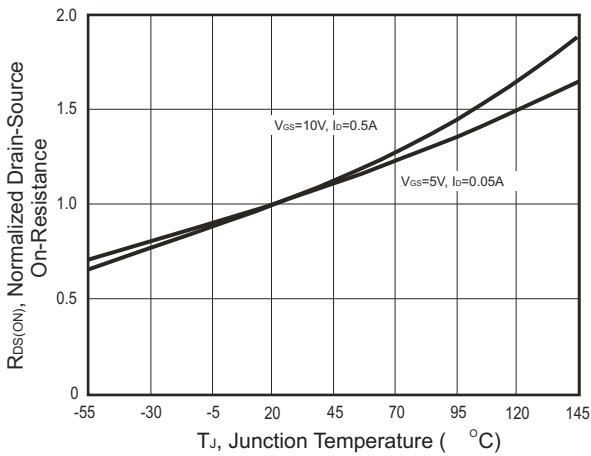
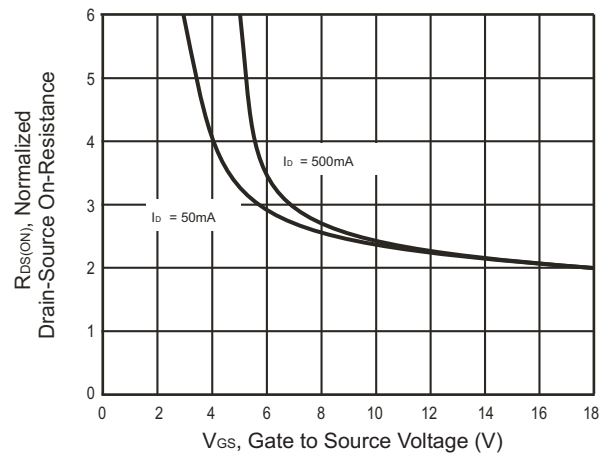
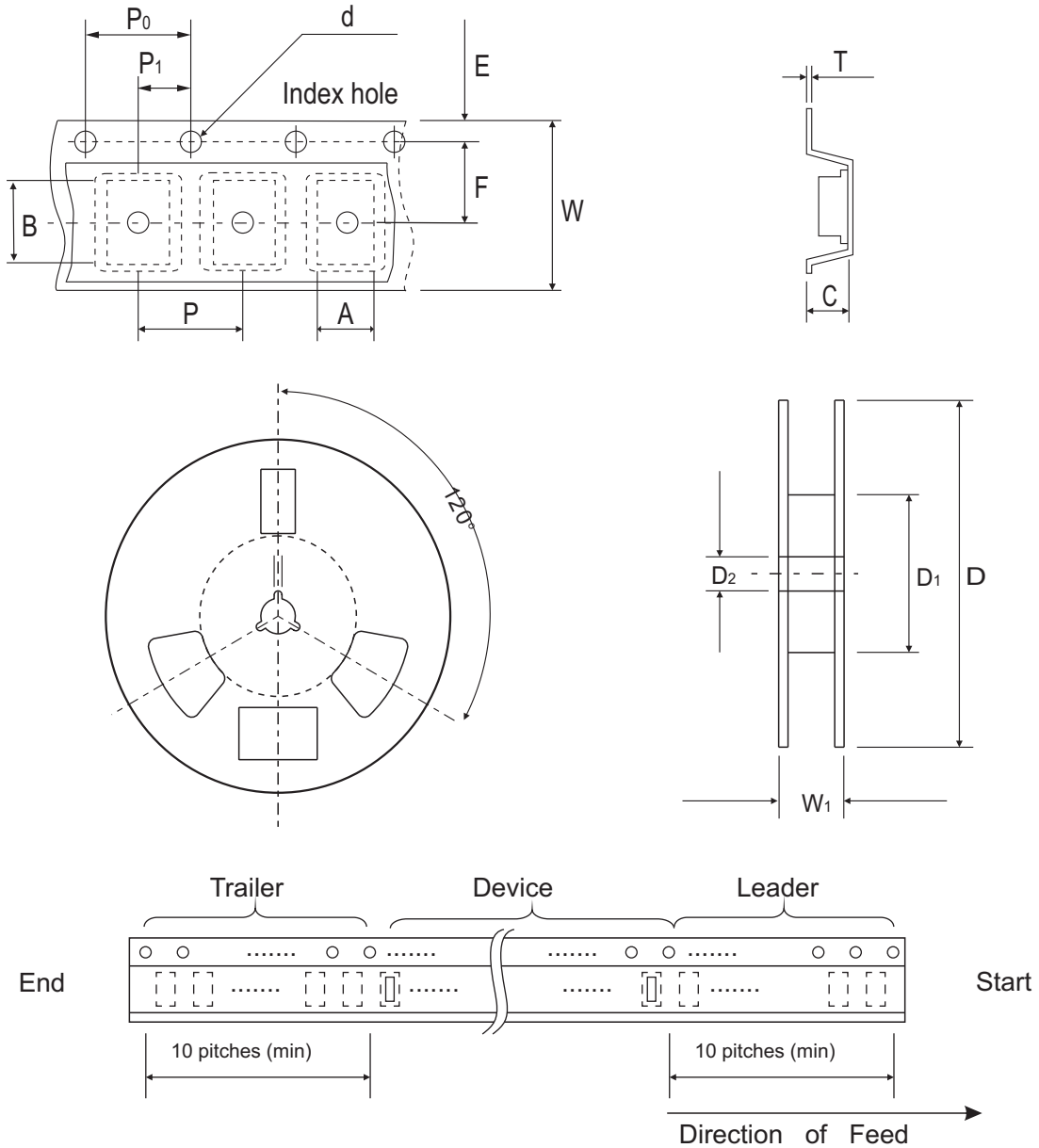

Fig.4 On-Resistance vs Gate-Source Voltage



Reel Taping Specification



SOT-23	SYMBOL	A	B	C	d	D	D ₁	D ₂
	(mm)	3.10 ± 0.10	2.85 ± 0.10	1.40 ± 0.10	1.55 ± 0.10	178 ± 1	50.0 MIN.	13.0 ± 0.20
	(inch)	0.122 ± 0.004	0.112 ± 0.004	0.055 ± 0.004	0.061 ± 0.004	7.008 ± 0.04	1.969 MIN.	0.512 ± 0.008

SOT-23	SYMBOL	E	F	P	P ₀	P ₁	W	W ₁
	(mm)	1.75 ± 0.10	3.50 ± 0.05	4.00 ± 0.10	4.00 ± 0.10	2.00 ± 0.05	8.00 ± 0.30	14.4 MAX.
	(inch)	0.069 ± 0.004	0.138 ± 0.002	0.157 ± 0.004	0.157 ± 0.004	0.079 ± 0.002	0.315 ± 0.012	0.567 MAX.

Marking Code

Part Number	Marking Code
2N7002-HF	7002

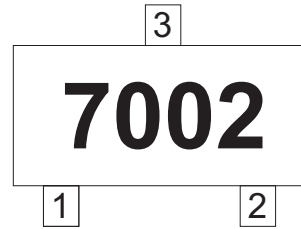

Suggested PAD Layout

SIZE	SOT-23	
	(mm)	(inch)
A	0.80	0.031
B	1.90	0.075
C	2.02	0.080
D	2.82	0.111

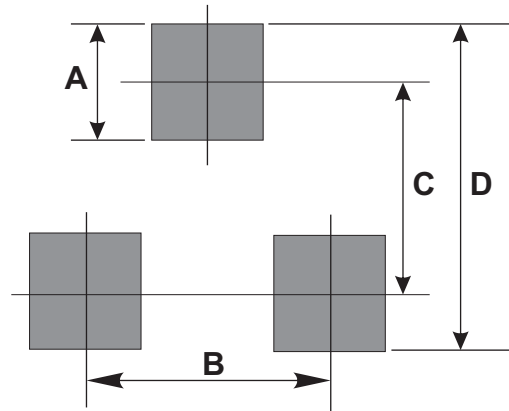

Standard Packaging

Case Type	Qty per Reel	Reel Size
	(Pcs)	(inch)
SOT-23	3000	7