

Signal conditioner - MACX MCR-UI-UI-NC - 2811446

Please be informed that the data shown in this PDF Document is generated from our Online Catalog. Please find the complete data in the user's documentation. Our General Terms of Use for Downloads are valid (<http://phoenixcontact.com/download>)



Configurable 3-way isolating amplifier with safe electrical isolation, 24 V, power bridging. DIP switches on the front, over 1600 signal conversions can be set. Standard configuration (IN 0 ... 10 V/OUT 0 ... 20 mA), screw connection, SIL.

Product Features

- ✓ Power supply possible via DIN rail connector
- ✓ Over 1600 signal conversions can be set via DIP switches on the front
- ✓ Installation in zone 2 permitted
- ✓ Up to SIL 2 according to EN 61508
- ✓ 3-way electrical isolation
- ✓ Analog signal conditioner for isolating, filtering, amplifying, and converting standard analog signals
- ✓ Configurable input and output signals, including bipolar current and voltage signals
- ✓ 10 kHz limit frequency for time-critical applications
- ✓ Status indicator for supply voltage
- ✓ Active or passive output
- ✓ Plug-in screw or spring-cage connection technology (Push-in technology)



Key commercial data

Packing unit	1 pc
Weight per Piece (excluding packing)	160.0 GRM
Custom tariff number	85437090
Country of origin	Germany

Technical data

Note

Utilization restriction	EMC: class A product, see manufacturer's declaration in the download area
-------------------------	---

Signal conditioner - MACX MCR-UI-UI-NC - 2811446

Technical data

Dimensions

Width	12.5 mm
Height	99 mm
Depth	114.5 mm

Ambient conditions

Ambient temperature (operation)	-20 °C ... 70 °C
Ambient temperature (storage/transport)	-40 °C ... 85 °C
Maximum altitude	≤ 2000 m
Degree of protection	IP20

Input data

Voltage input signal	0 mV ... 50 mV
	0 mV ... 60 mV
	0 mV ... 75 mV
	0 mV ... 100 mV
	0 mV ... 120 mV
	0 mV ... 150 mV
	0 mV ... 200 mV
	0 mV ... 300 mV
	0 mV ... 500 mV
	0 V ... 1 V
	0 V ... 1.5 V
	0 V ... 2 V
	0 V ... 3 V
	0 V ... 5 V
	0 V ... 10 V (please indicate if different setting when ordering)
	0 V ... 15 V
	0 V ... 20 V
	0 V ... 30 V
	0 V ... 50 V
	0 V ... 100 V
	-50 mV ... 50 mV
	-60 mV ... 60 mV
	-75 mV ... 75 mV
	-100 mV ... 100 mV
	-120 mV ... 120 mV
	-150 mV ... 150 mV
	-200 mV ... 200 mV

Signal conditioner - MACX MCR-UI-UI-NC - 2811446

Technical data

Input data

	-300 mV ... 300 mV
	-500 mV ... 500 mV
	-1 V ... 1 V
	-1.5 V ... 1.5 V
	-2 V ... 2 V
	-3 V ... 3 V
	-5 V ... 5 V
	-10 V ... 10 V
	-15 V ... 15 V
	-20 V ... 20 V
	-30 V ... 30 V
	-50 V ... 50 V
	-100 V ... 100 V
	1 V ... 5 V
	2 V ... 10 V
Current input signal	0 mA ... 1 mA (Configurable via DIP switches)
	0 mA
	0 mA ... 2 mA
	0 mA ... 3 mA
	0 mA ... 5 mA
	0 mA ... 10 mA
	0 mA ... 15 mA
	0 mA ... 20 mA
	0 mA ... 30 mA
	0 mA ... 50 mA
	0 mA ... 100 mA
	-1 mA ... 1 mA
	-1.5 mA ... 1.5 mA
	-2 mA ... 2 mA
	-3 mA ... 3 mA
	-5 mA ... 5 mA
	-10 mA ... 10 mA
	-15 mA ... 15 mA
	-20 mA ... 20 mA
	-30 mA ... 30 mA
	-50 mA ... 50 mA
	-100 mA ... 100 mA

Signal conditioner - MACX MCR-UI-UI-NC - 2811446

Technical data

Input data

	1 mA ... 5 mA
	2 mA ... 10 mA
	4 mA ... 20 mA
Min. input voltage	± 50 mV
Max. input voltage	± 100 V
Max. input current	± 100 mA
Input resistance of voltage input	approx. 1 MΩ (± 1 V DC ... ± 100 V DC)
Input resistance current input	approx. 10 Ω (± 10 mA DC ... ± 100 mA DC)

Output data

Configurable/programmable	Yes, can be switched
Voltage output signal	0 V ... 10 V (Configurable via DIP switches)
	0 V ... 5 V
	2 V ... 10 V
	1 V ... 5 V
	-10 V ... 10 V
	-5 V ... 5 V
	0 V ... 2.5 V
	0.5 V ... 2.5 V
	-2.5 V ... 2.5 V
Current output signal	0 mA ... 5 mA
	0 mA ... 10 mA
	0 mA ... 20 mA (please indicate if different setting when ordering)
	1 mA ... 5 mA
	2 mA ... 10 mA
	4 mA ... 20 mA
	-5 mA ... 5 mA
	-10 mA ... 10 mA
	-20 mA ... 20 mA
Load/output load voltage output	≥ 1 kΩ (10 V)
Load/output load current output	≤ 600 Ω (20 mA; active)
	passive: ≤ (UB-2 V) / I _{outmax}

Power supply

Supply voltage range	12 V DC ... 24 V DC (-20% / +25%)
----------------------	-----------------------------------

Connection data

Connection method	Screw connection
Conductor cross section solid min.	0.2 mm ²

Signal conditioner - MACX MCR-UI-UI-NC - 2811446

Technical data

Connection data

Conductor cross section solid max.	2.5 mm ²
Conductor cross section AWG/kcmil min.	24
Conductor cross section AWG/kcmil max	14
Conductor cross section stranded min.	0.2 mm ²
Conductor cross section stranded max.	2.5 mm ²
Stripping length	7 mm
Screw thread	M3

General

Maximum transmission error	≤ 0.1 % (Compared to the final value)
Maximum temperature coefficient	0.0075 %/K
Limit frequency (3 dB)	10 kHz (Can be switched to 30 Hz)
Alignment zero	± 4 %
Alignment span	± 4 %
Step response (10-90%)	35 µs (at 10 kHz)
	11 ms (At 30 Hz)
Protective circuit	Transient protection
Surge voltage category	II
Pollution degree	2
Rated insulation voltage	300 V AC
Test voltage, input/output/supply	2.5 kV (50 Hz, 1 min.)
Electromagnetic compatibility	Conformance with EMC Directive 2004/108/EC
Color	green
Housing material	PA 66-FR
Mounting position	any
Conformance	CE-compliant
ATEX	# II 3 G Ex nA IIC T4 Gc
IECEX	Ex nA IIC T4 Gc
UL, USA / Canada	UL 61010 Listed
	Class I, Div. 2, Groups A, B, C, D T6
	Class I, Zone 2, Group IIC
Functional Safety (SIL)	SIL 2

Safety characteristic data

Integrity requirement	IEC 61508 - Low demand
Designation	Input isolator (live zero signals)
Architecture	Single-channel, 1oo1
Equipment type	Type A

Signal conditioner - MACX MCR-UI-UI-NC - 2811446

Technical data

Safety characteristic data

Safety Integrity Level (SIL)	Up to 2
Safe Failure Fraction (SFF)	83.43 %
MTBF	258 Years
λ_{SU}	3.16×10^{-7} (316 FIT)
λ_{SD}	0
λ_{DU}	6.28×10^{-8} (63 FIT)
λ_{DD}	0
Probability of a hazardous failure on demand (PFD_{AVG})	2.76×10^{-4} (1 year)
Diagnostic coverage (DC)	0 %
Integrity requirement	IEC 61508 - Low demand
Designation	Output isolator (live zero signals)
Architecture	Single-channel, 1oo1
Equipment type	Type A
Safety Integrity Level (SIL)	Up to 2
Safe Failure Fraction (SFF)	82.92 %
MTBF	258 Years
λ_{SU}	3.14×10^{-7} (314 FIT)
λ_{SD}	0
λ_{DU}	6.48×10^{-8} (65 FIT)
λ_{DD}	0
Probability of a hazardous failure on demand (PFD_{AVG})	2.84×10^{-4} (1 year)
Diagnostic coverage (DC)	0 %
Integrity requirement	IEC 61508 - High demand
Designation	Input isolator (live zero signals)
Architecture	Single-channel, 1oo1
Equipment type	Type A
Safety Integrity Level (SIL)	Up to 2
Safe Failure Fraction (SFF)	83.43 %
MTBF	258 Years
λ_{SU}	3.16×10^{-7} (316 FIT)
λ_{SD}	0
λ_{DU}	6.28×10^{-8} (63 FIT)
λ_{DD}	0
Probability of a hazardous failure per hour (PFH_D)	$6,28 \times 10^{-8}$
Diagnostic coverage (DC)	0 %
Integrity requirement	IEC 61508 - High demand

Signal conditioner - MACX MCR-UI-UI-NC - 2811446

Technical data

Safety characteristic data

Designation	Output isolator (live zero signals)
Architecture	Single-channel, 1oo1
Equipment type	Type A
Safety Integrity Level (SIL)	Up to 2
Safe Failure Fraction (SFF)	82.92 %
MTBF	258 Years
λ_{SU}	3.14×10^{-7} (314 FIT)
λ_{SD}	0
λ_{DU}	6.48×10^{-8} (65 FIT)
λ_{DD}	0
Probability of a hazardous failure per hour (PFH _D)	$6,48 \times 10^{-8}$
Diagnostic coverage (DC)	0 %

Classifications

eCl@ss

eCl@ss 4.0	27210120
eCl@ss 4.1	27210120
eCl@ss 5.0	27210120
eCl@ss 5.1	27210120
eCl@ss 6.0	27210120
eCl@ss 7.0	27210120
eCl@ss 8.0	27210120

ETIM

ETIM 2.0	EC001485
ETIM 3.0	EC001485
ETIM 4.0	EC001485
ETIM 5.0	EC001485

UNSPSC

UNSPSC 6.01	30211506
UNSPSC 7.0901	39121008
UNSPSC 11	39121008
UNSPSC 12.01	39121008
UNSPSC 13.2	39121008

Signal conditioner - MACX MCR-UI-UI-NC - 2811446

Approvals

Approvals

Approvals

Functional Safety

Ex Approvals

IECEX / UL Listed / cUL Listed / cULus Listed

Approvals submitted

Approval details

Functional Safety

Drawings

Dimensioned drawing

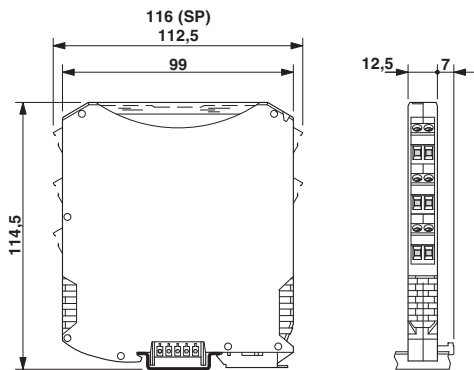

Block diagram

