

Electronic housing - UMK-BE 45 BK - 2971894

Please be informed that the data shown in this PDF Document is generated from our Online Catalog. Please find the complete data in the user's documentation. Our General Terms of Use for Downloads are valid (<http://phoenixcontact.com/download>)



Electronic board base, plug-in module base element

The figure shows a combination of versions UMK SE 11,25, UMK BE 11,25,- 22,5, -45 and UMK-FE, in green



Key Commercial Data

Packing unit	1 STK
Minimum order quantity	10 STK
GTIN	 4 017918 280772
GTIN	4017918280772
Weight per Piece (excluding packing)	18.170 g
Custom tariff number	85369010
Country of origin	Poland

Technical data

General

Housing type	Panel mounting base
Housing material	Polyamide
Color (RAL)	black (9005)

Ambient conditions

Ambient temperature (operation)	-40 °C ... 105 °C
---------------------------------	-------------------

Dimensions

Width	56.25 mm
-------	----------

Electronic housing - UMK-BE 45 BK - 2971894

Technical data

Dimensions

Depth	77 mm
-------	-------

Standards and Regulations

Flammability rating according to UL 94	V2
--	----

Environmental Product Compliance

China RoHS	Environmentally friendly use period: unlimited = EFUP-e
	No hazardous substances above threshold values

Drawings

Dimensional drawing

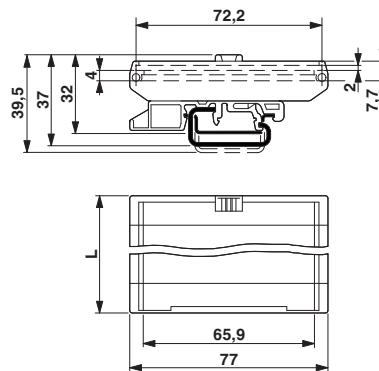

Classifications

eCl@ss

eCl@ss 4.0	27180401
eCl@ss 4.1	27180401
eCl@ss 5.0	27180506
eCl@ss 5.1	27180506
eCl@ss 6.0	27180802
eCl@ss 7.0	27182701
eCl@ss 8.0	27182701
eCl@ss 9.0	27182701

ETIM

ETIM 2.0	EC001031
ETIM 3.0	EC001031
ETIM 4.0	EC001031

Electronic housing - UMK-BE 45 BK - 2971894

Classifications

ETIM

ETIM 5.0	EC002779
ETIM 6.0	EC002779

UNSPSC

UNSPSC 6.01	31261501
UNSPSC 7.0901	31261501
UNSPSC 11	31261501
UNSPSC 12.01	31261501
UNSPSC 13.2	31261501

Approvals

Approvals

Approvals

UL Recognized

Ex Approvals

Approval details

UL Recognized		http://database.ul.com/cgi-bin/XYV/template/LISEXT/1FRAME/index.htm	FILE E 240868
---------------	---	---	---------------

Accessories

Accessories

Mounting flange - UMK-BF BK - 2906380

Mounting flange, for mounting directly on the wall

Electronic housing - UMK-BE 45 BK - 2971894

Accessories

Electronic housing - UMK-BE 22,5 BK - 2971904



Electronic board base, plug-in module base element

Foot element - UMK-FE BK - 2971917

Foot element, for mounting on DIN rail NS 32 or DIN rail NS 35/7.5, can be inserted between base and side element

Electronic housing - UMK-BE 11,25 BK - 2976394



Electronic board base, plug-in module base element
