

Variable Transformers
Series 100/200 • 0.8 to 3.0 Amperes

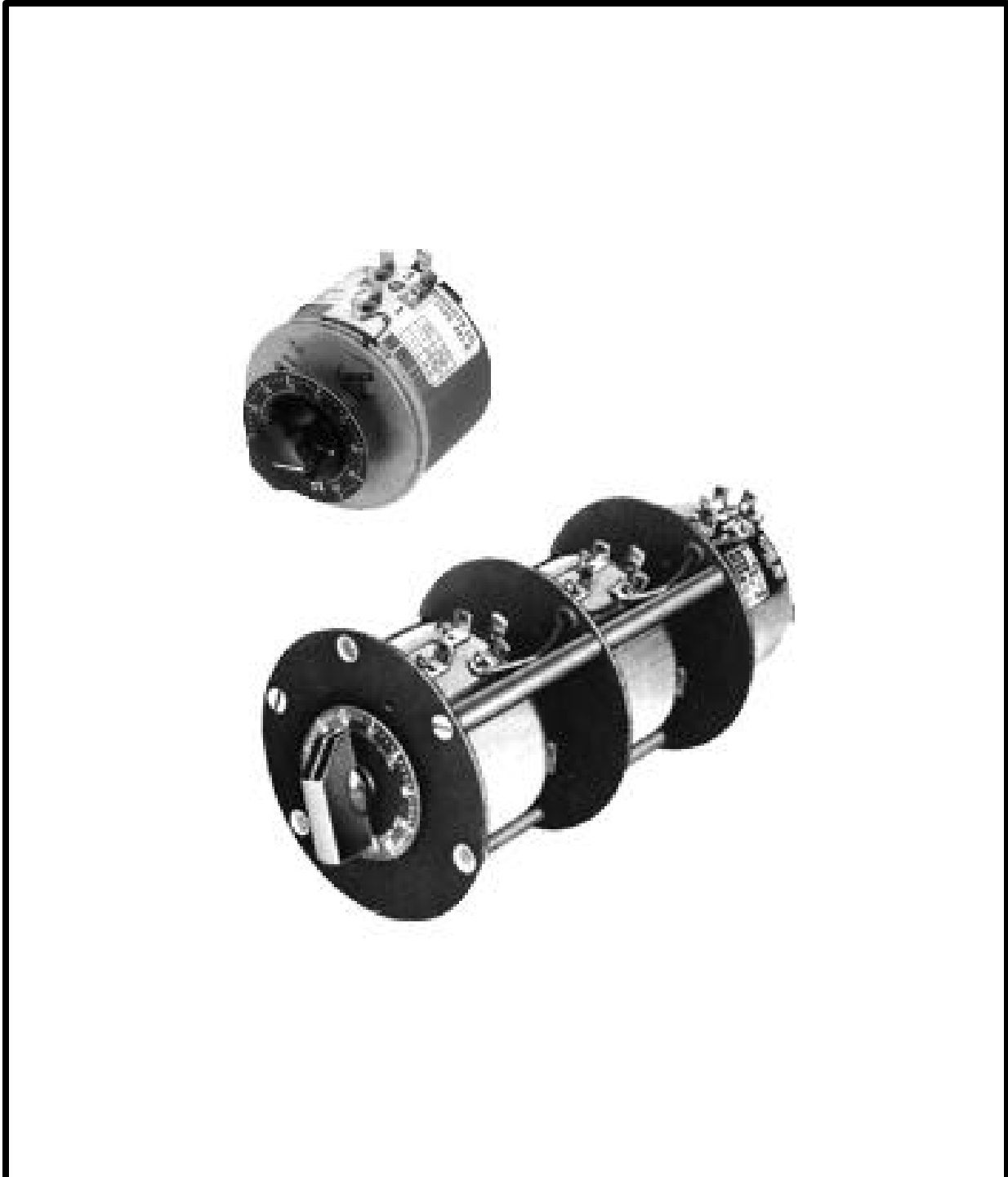

100/200 Series

These manually operated panel mounted units are available in single and three phase models from 0.8 to 3.0 amperes. The 171, 201, 221-B and 291 units operate from 120 volt input, while the 252 unit operates from a 240 volt input. STACO's coil tapping arrangement permits an output voltage from 0 to line

voltage in either the clockwise or counterclockwise direction and from 0 to 10% above line voltage in the clockwise direction. Two and three ganged, manually operated units are available for increased single phase voltage ratings and for three phase applications.

PART NO.	WIRING	INPUT		OUTPUT				SHAFT ROTATION FOR VOLTAGE INCREASE	TERMINAL CONNECTIONS (For increasing Voltage) As Viewed from Base End			SCHEMATIC (Pg 8 & 9)	NET WT. LBS.	
		VOLTS	HERTZ	VOLTS	CONSTANT CURRENT LOAD		CONSTANT IMPEDANCE LOAD		Input	Jumper*	Output			
					MAX AMPS	MAX KVA	MAX AMPS							MAX KVA
171	Single Phase	120	50/60	0-120	1.75	0.21	2.2	0.26	CW	1-2	—	1-3	1	2
			60	0-132	1.75	0.23	—	—	CCW	1-2	—	2-3		
									CW	1-4	—	1-3		
171-2	Single Phase Series	240	50/60	0-240	1.75	0.42	2.2	0.53	CW	2-2	1-1	3-3	1 & 4	4 1/4
			60	0-264	1.75	0.46	—	—	CCW	1-1	2-2	3-3		
									CW	4-4	1-1	3-3		
	Three Phase Open Delta π	120++	50/60	0-120	1.75	0.36	2.2	0.46	CW	2-1-2	1-1	3-1-3	1 & 5	4 1/4
			60	0-132	1.75	0.40	—	—	CCW	1-2-1	2-2	3-2-3		
									CW	4-1-4	1-1	3-1-3		
171-3	Three Phase Wye π	240++	60	0-240	1.75	0.73	2.2	0.92	CW	2-2-2	1-1-1	3-3-3	1 & 6	6 1/2
									CCW	1-1-1	2-2-2	3-3-3		
201	Single Phase	120	50/60	0-120	2.0	0.24	2.5	0.30	CW	1-2	—	1-3	1	2
			60	0-132	2.0	0.26	—	—	CCW	1-2	—	2-3		
									CW	1-4	—	1-3		
201-2	Single Phase Series	240	50/60	0-240	2.0	0.48	2.5	0.60	CW	2-2	1-1	3-3	1 & 4	4 1/4
			60	0-264	2.0	0.53	—	—	CCW	1-1	2-2	3-3		
									CW	4-4	1-1	3-3		
	Three Phase Open Delta π	120++	50/60	0-120	2.0	0.42	2.5	0.52	CW	2-1-2	1-1	3-1-3	1 & 5	4 1/4
			60	0-132	2.0	0.46	—	—	CCW	1-2-1	2-2	3-2-3		
									CW	4-1-4	1-1	3-1-3		
201-3	Three Phase Wye π	240++	60	0-240	2.0	0.83	2.5	1.04	CW	2-2-2	1-1-1	3-3-3	1 & 6	6 1/2
									CCW	1-1-1	2-2-2	3-3-3		
221-B	Single Phase	120	50/60	0-120	2.5	0.30	3.2	0.38	CW	1-2	—	1-3	1	2 1/2
			60	0-132	2.5	0.33	—	—	CCW	1-2	—	2-3		
									CW	1-4	—	1-3		
221-B-2	Single Phase Series	240	50/60	0-240	2.5	0.60	3.2	0.77	CW	2-2	1-1	3-3	1 & 4	5 1/2
			60	0-264	2.5	0.66	—	—	CCW	1-1	2-2	3-3		
									CW	4-4	1-1	3-3		
	Three Phase Open Delta π	120++	50/60	0-120	2.5	0.52	3.2	0.67	CW	2-1-2	1-1	3-1-3	1 & 5	5 1/2
			60	0-132	2.5	0.57	—	—	CCW	1-2-1	2-2	3-2-3		
									CW	4-1-4	1-1	3-1-3		
221-B-3	Three Phase Wye π	240++	60	0-240	2.5	1.04	3.2	1.33	CW	2-2-2	1-1-1	3-3-3	1 & 6	8 1/4
									CCW	1-1-1	2-2-2	3-3-3		
3PN221B	Single Phase	120	60	0-132	2.50	0.33	—	—	CW	LINE CORD & RECEPTACLE			3	3
252	Single Phase	240	50/60	0-240	0.8	0.19	1.0	0.24	CW	1-2	—	1-3	1	2 1/2
			60	0-264	0.8	0.21	—	—	CCW	1-2	—	2-3		
									CW	1-4	—	1-3		
252-2	Single Phase Series	480	50/60	0-480	0.8	0.38	1.0	0.48	CW	2-2	1-1	3-3	1 & 4	5 1/2
			60	0-528	0.8	0.42	—	—	CCW	1-1	2-2	3-3		
									CW	4-4	1-1	3-3		
	Three Phase Open Delta π	240++	50/60	0-240	0.8	0.33	1.0	0.42	CW	2-1-2	1-1	3-1-3	1 & 5	5 1/2
			60	0-264	0.8	0.37	—	—	CCW	1-2-1	2-2	3-2-3		
									CW	4-1-4	1-1	3-1-3		
252-3	Three Phase Wye π	480++	50/60	0-480	0.8	0.67	1.0	0.83	CW	2-2-2	1-1-1	3-3-3	1 & 6	8 1/4
			60	0-528	0.8	0.73	—	—	CCW	1-1-1	2-2-2	3-3-3		
									CW	4-4-4	1-1-1	3-3-3		

100/200 Series

PART NO.	WIRING	INPUT		OUTPUT				SHAFT ROTATION FOR VOLTAGE INCREASE	TERMINAL CONNECTIONS (For increasing Voltage) As Viewed from Base End			SCHE-MATIC (Pg 8 & 9)	NET WT. LBS.	
		VOLTS	HERTZ	VOLTS	CONSTANT CURRENT LOAD		CONSTANT IMPEDANCE LOAD		Input	Jumper*	Output			
					MAX AMPS	MAX KVA	MAX AMPS							MAX KVA
291	Single Phase	120	50/60	0-120	3.0	0.36	3.5	0.42	CW	1-2	—	1-3	1	2 1/2
			60	0-132	3.0	0.40	—	—	CCW	1-2	—	2-3		
										CW	1-4	—		
291-2	Single Phase Series	240	50/60	0-240	3.0	0.72	3.5	0.84	CW	2-2	1-1	3-3	1 & 4	5 1/2
			60	0-264	3.0	0.79	—	—	CCW	1-1	2-2	3-3		
										CW	4-4	1-1		
	Three Phase Open Delta π	120++	50/60	0-120	3.0	0.62	3.5	0.73	CW	2-1-2	1-1	3-1-3	1 & 5	5 1/2
			60	0-132	3.0	0.69	—	—	CCW	1-2-1	2-2	3-2-3		
										CW	4-1-4	1-1		
291-3	Three Phase Wye π	240++	60	0-240	3.0	1.25	3.5	1.45	CW	2-2-2	1-1-1	3-3-3	1 & 6	8 1/4
									CCW	1-1-1	2-2-2	3-3-3		

* Jumper provided in the standard common position and should be moved or removed as required.

++ Line to line voltage

π If ganged units are used in a system that ordinarily has a common neutral or ground between source and load, the neutral or ground must be connected to the common terminals of the variable transformer assembly. If the system has no neutral, the load must be balanced or the transformers will be damaged.



221-B

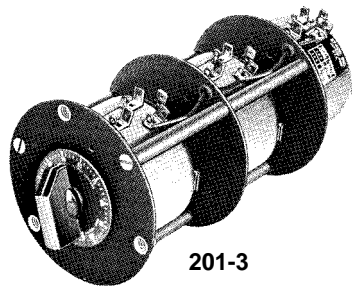

201-3

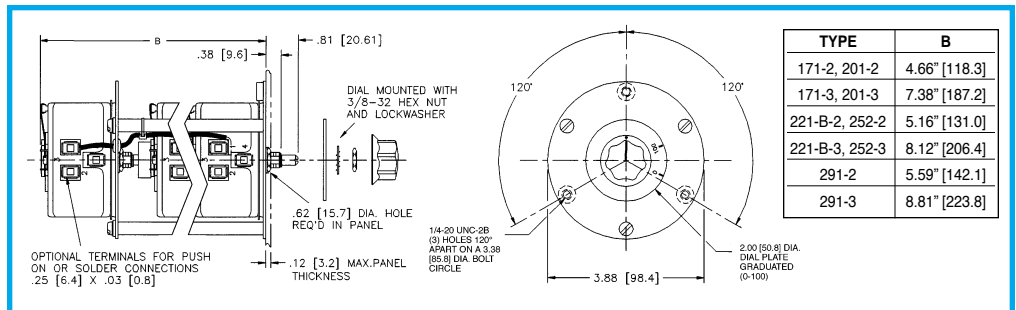
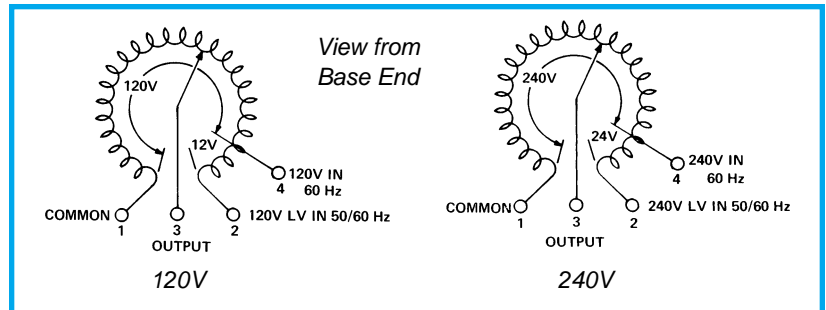

Two and Three Gang Units

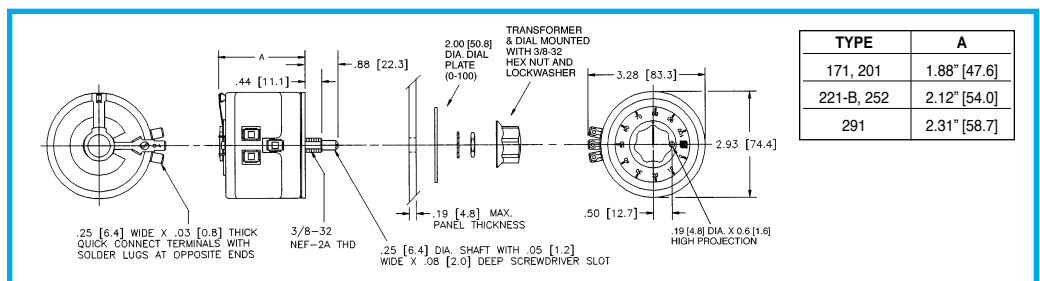

Single Unit