

AUTOMATION

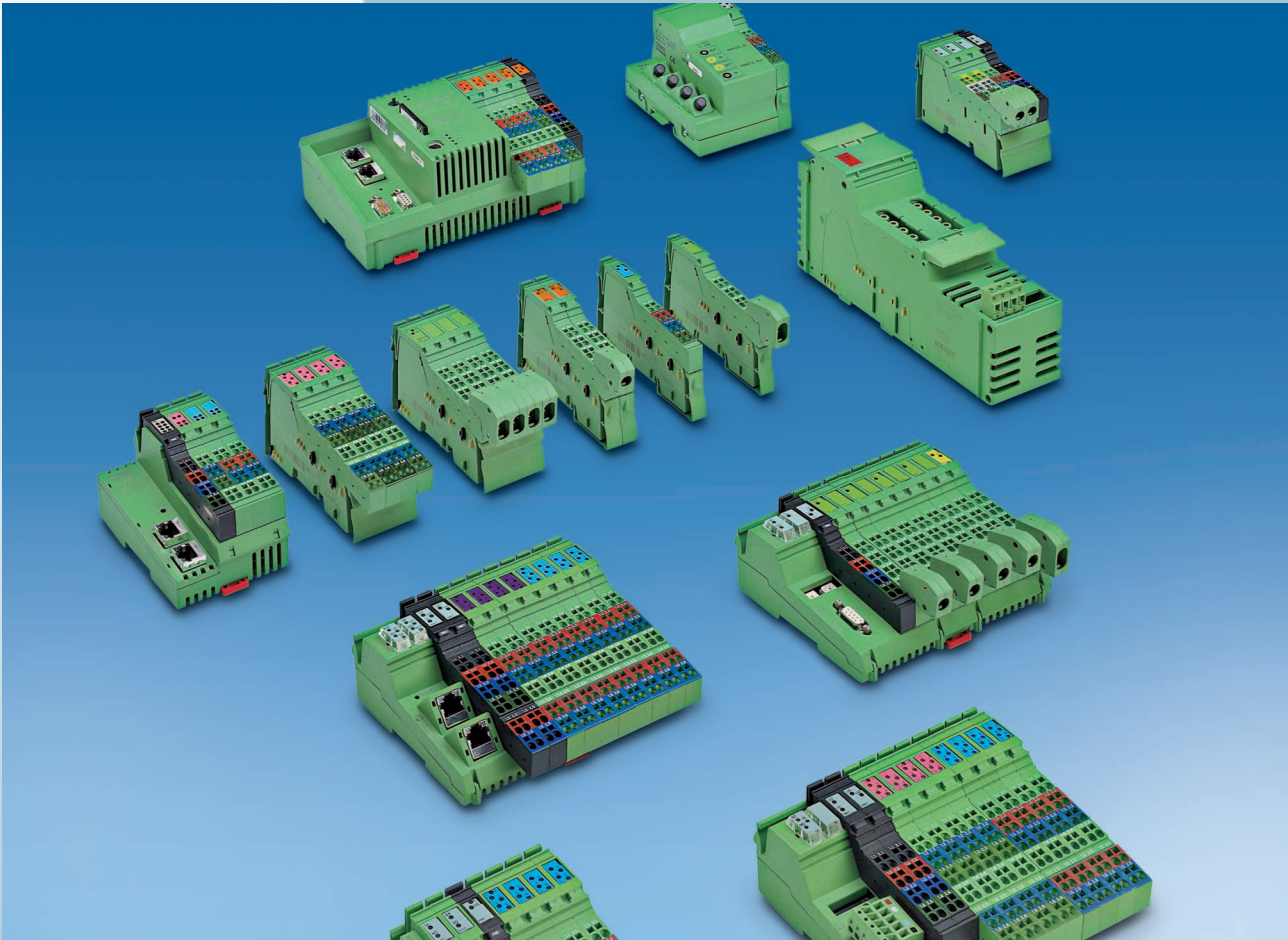

User Manual

IL SYS INST UM E

Order No.: 2698737

Automation terminals
of the Inline product range

onlinecomponents.com

AUTOMATION

User Manual

Automation terminals of the Inline product range

07/2008

Designation: IL SYS INST UM E

Revision: 02

Order No.: 2698737

This user manual is valid for:

All automation terminals in the Inline product range without
bus couplers and bus-specific special features

Please observe the following notes

In order to ensure the safe use of the product described, you have to read and understand this manual. The following notes provide information on how to use this manual.

User group of this manual

The use of products described in this manual is oriented exclusively to qualified electricians or persons instructed by them, who are familiar with applicable standards and other regulations regarding electrical engineering and, in particular, the relevant safety concepts.

Phoenix Contact accepts no liability for erroneous handling or damage to products from Phoenix Contact or third-party products resulting from disregard of information contained in this manual.

Explanation of symbols used and signal words



This is the safety alert symbol. It is used to alert you to potential personal injury hazards. Obey all safety messages that follow this symbol to avoid possible injury or death.



DANGER

This indicates a hazardous situation which, if not avoided, will result in death or serious injury.



WARNING

This indicates a hazardous situation which, if not avoided, could result in death or serious injury.



CAUTION

This indicates a hazardous situation which, if not avoided, could result in minor or moderate injury.

The following types of messages provide information about possible property damage and general information concerning proper operation and ease-of-use.



NOTE

This symbol and the accompanying text alerts the reader to a situation which may cause damage or malfunction to the device, either hardware or software, or surrounding property.



This symbol and the accompanying text provides additional information to the reader. It is also used as a reference to other sources of information (manuals, data sheets, literature) on the subject matter, product, etc.

General terms and conditions of use for technical documentation

Phoenix Contact reserves the right to alter, correct, and/or improve the technical documentation and the products described in the technical documentation at its own discretion and without giving prior notice, insofar as this is reasonable for the user. The same applies to any technical changes that serve the purpose of technical progress.

The receipt of technical documentation (in particular data sheets, installation instructions, manuals, etc.) does not constitute any further duty on the part of Phoenix Contact to furnish information on alterations to products and/or technical documentation. Any other agreement shall only apply if expressly confirmed in writing by Phoenix Contact. Please note that the supplied documentation is product-specific documentation only and that you are responsible for checking the suitability and intended use of the products in your specific application, in particular with regard to observing the applicable standards and regulations. Although Phoenix Contact makes every effort to ensure that the information content is accurate, up-to-date, and state-of-the-art, technical inaccuracies and/or printing errors in the information cannot be ruled out. Phoenix Contact does not offer any guarantees as to the reliability, accuracy or completeness of the information. All information made available in the technical data is supplied without any accompanying guarantee, whether expressly mentioned, implied or tacitly assumed. This information does not include any guarantees regarding quality, does not describe any fair marketable quality, and does not make any claims as to quality guarantees or guarantees regarding the suitability for a special purpose.

Phoenix Contact accepts no liability or responsibility for errors or omissions in the content of the technical documentation (in particular data sheets, installation instructions, manuals, etc.).

The aforementioned limitations of liability and exemptions from liability do not apply, in so far as liability must be assumed, e.g., according to product liability law, in cases of premeditation, gross negligence, on account of loss of life, physical injury or damage to health or on account of the violation of important contractual obligations. Claims for damages for the violation of important contractual obligations are, however, limited to contract-typical, predictable damages, provided there is no premeditation or gross negligence, or that liability is assumed on account of loss of life, physical injury or damage to health. This ruling does not imply a change in the burden of proof to the detriment of the user.

IL SYS INST UM E

Statement of legal authority

This manual, including all illustrations contained herein, is copyright protected. Use of this manual by any third party is forbidden. Reproduction, translation, and public disclosure, as well as electronic and photographic archiving or alteration requires the express written consent of Phoenix Contact. Violators are liable for damages.

Phoenix Contact reserves all rights in the case of patent award or listing of a registered design. Third-party products are always named without reference to patent rights. The existence of such rights shall not be excluded.

How to contact us

Internet

Up-to-date information on Phoenix Contact products and our Terms and Conditions can be found on the Internet at:

www.phoenixcontact.com.

Make sure you always use the latest documentation.

It can be downloaded at:

www.download.phoenixcontact.com.

A conversion table is available on the Internet at:

www.download.phoenixcontact.com/general/7000_en_00.pdf.

Subsidiaries

If there are any problems that cannot be solved using the documentation, please contact your Phoenix Contact subsidiary.

Subsidiary contact information is available at www.phoenixcontact.com.

Published by

PHOENIX CONTACT GmbH & Co. KG
Flachmarktstraße 8
32825 Blomberg
Germany
Phone +49 - (0) 52 35 - 3-00
Fax +49 - (0) 52 35 - 3-4 12 00

PHOENIX CONTACT
P.O. Box 4100
Harrisburg, PA 17111-0100
USA
Phone +1-717-944-1300

Should you have any suggestions or recommendations for improvement of the contents and layout of our manuals, please send your comments to

tecdoc@phoenixcontact.com.

Table of Contents

1	Documentation landscape of Inline	1-1
2	The Inline product range	2-1
	2.1 Features	2-1
	2.2 Product description.....	2-2
3	Important information about voltage areas	3-1
	3.1 Voltage areas for Inline Modular IO and Inline Block IO	3-1
	3.2 Correct usage	3-2
	3.3 Notes for Inline Modular IO	3-2
	3.3.1 Safety notes for use in the low voltage area	3-2
	3.3.2 Safety notes for electrical equipment used in industrial plants with a 400 V AC voltage	3-3
	3.3.3 Installation instructions and notes for low voltage terminals	3-3
	3.3.4 Electronics base and connectors for the different voltage areas	3-5
	3.3.5 Safety mechanisms to prevent incorrect connection of terminals for different voltage areas	3-5
	3.3.6 Response to the connection of a 120 V AC or 230 V AC terminal in the 24 V DC area	3-6
4	Inline product groups	4-1
	4.1 Supported bus systems	4-1
	4.2 Inline Modular IO terminals	4-2
	4.2.1 Scope of supply and transmission speed	4-2
	4.2.2 Example of an Inline station	4-3
	4.2.3 Bus couplers and terminals with remote bus branch	4-4
	4.2.4 Power, segment, and accessory terminals	4-4
	4.2.5 I/O terminals	4-12
	4.2.6 Power-level terminals	4-14
	4.2.7 Servo amplifier	4-16
	4.2.8 Safety terminals	4-17
	4.2.9 Programmable terminals (control terminals)	4-19
	4.2.10 Branch terminals	4-20
	4.2.11 Typical structure of an Inline Modular IO station	4-22
	4.3 Inline Block IO modules	4-23
5	Structure and dimensions	5-1
	5.1 Structure and dimensions of Inline Modular IO terminals.....	5-1
	5.1.1 Basic structure of terminals in the 24 V DC and 120 V AC/230 V AC areas	5-1
	5.1.2 Electronics base	5-2
	5.1.3 Connectors for terminals in the 24 V DC and 120 V AC/230 V AC areas	5-2

IL SYS INST UM E

5.1.4	Basic structure of power-level terminals	5-3
5.1.5	Connectors for power-level terminals	5-4
5.1.6	Function identification and labeling	5-5
5.1.7	Housing dimensions of terminals in the 24 V DC and 120 V AC/230 V AC areas	5-6
5.1.8	Dimensions of power-level terminals	5-11
5.2	Structure and dimensions of Inline Block IO modules	5-12
5.2.1	Basic structure of modules	5-12
5.2.2	Function identification and labeling	5-13
5.2.3	Housing dimensions	5-14
6	Inline connectors.....	6-1
6.1	Basic structure and dimensions of Inline connectors.....	6-1
6.2	Connectors for the 24 V DC area.....	6-3
6.3	Connectors for the 120 V AC/230 V AC area (Inline Modular IO).....	6-5
6.4	Numbering and labeling of terminal points.....	6-7
6.5	Terminal point keying	6-8
7	Electrical potential and data routing (Inline Modular IO).....	7-1
7.1	Circuits and provision of supply voltages.....	7-1
7.1.1	Bus coupler supply	7-1
7.1.2	Logic circuit	7-2
7.1.3	Analog circuit	7-2
7.1.4	Main circuit	7-3
7.1.5	Segment circuit	7-3
7.1.6	Mains voltage for power-level terminals	7-4
7.1.7	Example of a circuit diagram	7-6
7.2	Electrical potential and data routing.....	7-8
7.2.1	Arrangement of potential and data jumpers	7-8
7.2.2	Current and voltage distribution	7-12
8	Diagnostic and status indicators	8-1
8.1	Indicators on Inline Modular IO terminals.....	8-1
8.1.1	Indicators on bus couplers and terminals with remote bus branch	8-1
8.1.2	Indicators available on different terminals in the Inline system	8-2
8.1.3	Indicators on power and segment terminals	8-3
8.1.4	Indicators on I/O terminals	8-4
8.1.5	Indicators on power-level terminals	8-7
8.2	Indicators on Inline Block IO modules.....	8-7
8.2.1	Indicators in the bus system function area (BUS)	8-8
8.2.2	Indicators in the supply function area (PWR)	8-9
8.2.3	Indicators in the I/O function area (IN, OUT, IN/OUT)	8-10

Table of Contents

9	Mounting/removing devices	9-1
9.1	Installation instructions	9-1
9.1.1	Unpacking	9-1
9.1.2	Replacing a device	9-1
9.2	Basic information about mounting	9-1
9.3	Mounting distances	9-2
9.3.1	Mounting distances for Inline Modular IO terminals	9-3
9.3.2	Mounting distances for Inline Block IO modules	9-7
9.4	Grounding concept	9-8
9.4.1	Functional earth ground (FE)	9-8
9.4.2	Protective earth ground (PE) (Inline Modular IO)	9-10
9.5	Shielding concept	9-11
9.5.1	Inline shielding concept	9-11
9.5.2	Shielding when connecting analog sensors and actuators	9-11
9.6	Mounting/removal	9-13
9.6.1	Inline Modular IO: Mounting/removal	9-13
9.6.2	Inline Block IO: Mounting/removal	9-21
9.6.3	Order of the Inline Modular IO terminals	9-22
10	Connecting cables	10-1
10.1	Connecting cables using Inline connectors	10-1
10.1.1	Connecting unshielded cables	10-1
10.1.2	Connecting shielded cables using an Inline shield connector	10-2
10.2	Connecting the power supplies	10-6
10.2.1	Inline Modular IO: Supply options	10-6
10.2.2	Power supply requirements	10-7
10.3	Connecting the bus	10-8
10.4	Connecting sensors and actuators	10-9
10.4.1	Connection methods for sensors and actuators	10-9
10.4.2	Connections used for digital input and output terminals	10-10
10.4.3	The various connection methods for sensors and actuators	10-11
10.5	Connections on a power-level terminal (Inline Modular IO)	10-14
10.5.1	Connecting or forwarding the incoming mains	10-15
10.5.2	Connecting the motor circuit connector	10-17
10.5.3	Connecting the brake module and brake (optional)	10-19
10.5.4	Connecting the hand-held operator panel	10-20
10.5.5	Enabling the power level/24 V isolation	10-21
11	Inline Modular IO: Technical data and ordering data	11-1
11.1	Technical data for Inline Modular IO	11-1
11.2	Ordering data	11-7

IL SYS INST UM E

A	Inline Modular IO: Additional information	A-1
A 1	Tips for working with Inline.....	A-1
A 2	Configuration help for selecting the optimum analog input device for temperature recording	A-2
A 2.1	Inline Modular IO	A-2
A 2.2	Inline Block IO	A-3
A 3	Maximum cable lengths for analog devices	A-4
A 3.1	Analog input and temperature recording	A-4
A 3.2	Analog output	A-5
A 3.3	Analog I/O	A-5
A 4	Temperature response of the terminals	A-6
A 5	Calculation examples for power dissipation and working points	A-7
A 5.1	Constant power dissipation of the housing over the operating temperature range	A-7
A 5.2	Power dissipation of the housing within the operating temperature range depending on the ambient temperature	A-9
B	Software support	B-1
B 1	Overview of the software	B-1
B 2	AX SALES	B-2
B 3	CLIP PROJECT	B-3
B 4	Other software	B-3
C	Explanation of abbreviations and symbols	C-1
C 1	Explanation of abbreviations	C-1
C 2	Representations used in basic circuit diagrams.....	C-2
C 3	Frequently used symbols.....	C-3
D	Index.....	D-1

1 Documentation landscape of Inline

The documentation for the Inline product range is modular, providing you with the optimum information for your specific bus system, Inline Modular IO terminal or Inline Block IO module.



The documentation can be downloaded at www.download.phoenixcontact.com.
For a comprehensive list of the documentation, please refer to the ordering data (see "Ordering data" on page 11-7).
Terminal-specific documentation can be found in the download area for the corresponding device.
Make sure you always use the latest documentation.

"Automation terminals of the Inline product range" user manual, IL SYS INST UM E (this manual)



For Inline Modular IO and Inline Block IO.

This manual is the higher-level system manual for Inline and describes the use of terminals/modules for all bus systems.

User manuals (system, bus coupler or special terminal)



For Inline Modular IO.

The additional user manuals either describe:

- A bus system (e.g., INTERBUS)
- A bus coupler in association with a bus system (e.g., PROFIBUS DP) or
- A special Inline terminal (e.g., counter terminal, positioning terminal)

Each manual only describes the relevant terminal and/or bus-specific special features. As the higher-level manual, the "IL SYS INST UM E" user manual also applies.

"INTERBUS & AUTOMATION - Terms and definitions" reference manual, IBS TERM RG UM E



This manual provides an overview of technical terms and definitions in the field of INTERBUS & AUTOMATION.

Quick Start Guides



For Inline Modular IO.

A Quick Start Guide is available for various topics. A Quick Start Guide describes the startup of a system or a terminal step-by-step using an example.

Terminal/module-specific data sheets

For Inline Modular IO and Inline Block IO.



The data sheet describes the specific properties of each device. This includes at the very least:

- Function description
- Local diagnostic and status indicators
- Pin assignment/terminal point assignment and connection example
- Programming data/configuration data
- Technical data

"Summary of key data for Inline devices" data sheet, DB GB IB IL DEVICE LIST

For Inline Modular IO.



This data sheet is also referred to as a device list.

In addition to terminal-specific data sheets, this data sheet also includes the key data of every Inline Modular IO device. This includes, for example:

- Programming data: ID code, length code, process data channel, I/O address area
- Error messages
- Power supply/current consumption

Application notes

For Inline Modular IO and Inline Block IO.



Application notes provide additional information about special topics, such as:

- Overview of Inline terminals that can be used at various bus couplers AH IL BK IO LIST
- Information about addressing 16-channel Inline Block IO modules AH ILB 24 DI/DO 16 ADDRESS
- Information about addressing 32-channel Inline Block IO modules AH ILB 24 DI/DO 32 ADDRESS
- General information about the safety-related segment circuit AH EN IL SAFE
- General information about use in zone 2 potentially explosive areas AH EN IL EX ZONE 2
- Example for the use of a terminal with a specific software tool
- Example for the communication of a terminal with a specific control system
- Information about firmware versions of specific terminals
- Information about firmware updates



Package slips

For Inline Modular IO and Inline Block IO.

A package slip contains key information for the electrical installation of a device or group of devices. This includes, for example:

- Short description
- Safety notes
- Mounting/removal
- Terminal point assignment
- Local diagnostic and status indicators

onlinecomponents.com

IL SYS INST UM E

onlinecomponents.com

2 The Inline product range

The Inline product range consists of:

- Inline Modular IOs: Modular terminals
- Inline Block IOs: Compact remote I/O modules



This manual mainly describes the Inline Modular IOs, which are referred to as Inline terminals. For information about the Inline Block IOs, please refer to the module-specific data sheets.

2.1 Features

Inline Modular IO

- Can be easily installed side by side without tools
- Open, flexible, and modular structure
- Terminals of varying widths can be combined to create a time-saving, compact, and cost-effective station structure
- 2-slot terminals:
These terminals enable optimum adaptation to the desired configuration. They enable a flexible and compact station structure without unnecessary reserve installation space.
- 8-slot terminals:
These terminals provide a fast and effective station structure for larger stations.
- Functional orientation of the control box or control cabinet
The modular structure makes it possible to assemble standard function blocks in advance. Parts of the system can be started up independently of one another. This means that pretests can be carried out when the system is set up and the whole system can be adapted and extended.
- Automatic creation of isolated groups, potential circuits, and data circuits
- The amount of costly parallel wiring is reduced
Within a station, potential and data routing can be carried out without additional wiring.
- Supports all popular bus systems

Inline Block IO

- Integrated bus interface for all popular bus systems
- High channel density
- Compact 55 mm flat design
- Can be easily installed without tools
- Same look and feel as Inline Modular IO

2.2 Product description

Automation terminals with various functions are available within the Inline product range.

With just a few exceptions, the automation terminals consist of an electronics base (Inline Modular IO) or an electronic module (Inline Block IO) and one or more connectors for connecting the I/O or power supply. The electronics can be replaced without removing a single wire from the connector.

Inline Modular IO versions

The Inline product range offers terminals for all automation tasks:

- Bus couplers to integrate the Inline station into various bus systems, some with input and output function for digital signals
The bus can be connected using copper or fiber optic technology.
- Terminals with remote bus branch for opening an INTERBUS remote bus branch
The remote bus branch can be connected using copper or fiber optic technology.
- Terminals for supplying the supply voltages and segmenting the station (with and without fuse)
- Accessory terminals (potential distributor terminals, distance terminals)
- Input and output terminals for digital and analog signals
- Power-level terminals for switching, protecting, and monitoring three-phase standard motors
- Branch terminals for integrating further product ranges (e.g., integration of a Fieldline Modular local bus in the Inline station) or to extend the local bus by several rows
- Terminals for open and closed-loop control, communication, and position detection
- Safety terminals
- Programmable terminals (CPU and Inline Controller)

Inline Block IO versions

- Input modules, output modules, and I/O modules for digital and analog signals
- Bus interface is integrated in the module

Mounting location

Inline Modular IO terminals and Block IO modules meet IP20 protection and are designed for use in closed housing. The compact design means that most Inline Modular IO terminals and all Block IO modules can be installed in standard terminal boxes.

Mounting

Inline Modular IO terminals and Block IO modules can be snapped onto DIN rails without tools. Potential and data jumpers are automatically created when the Inline Modular IO terminals are properly installed.

Bus connection

Inline Modular IO: The Inline station is integrated in the bus system via a bus coupler. The bus is controlled by the Inline station through data routing.

Inline Block IO: The bus interface is integrated in the module. The bus is connected directly to the I/O module.

I/O connection

The Inline terminals and Block IO modules have connectors for 1, 2, 3, and 4-wire sensors or actuators. The wires are connected using spring-cage technology. For more detailed information, please refer to the individual sections.

3 Important information about voltage areas

3.1 Voltage areas for Inline Modular IO and Inline Block IO

Inline Block IO modules are available for the SELV area

Inline Modular IO terminals are available for the SELV and low voltage areas. The terminals are divided into three product groups according to their use in a specific voltage area and their function.

Table 3-1 Voltage areas and corresponding terminal designations for Inline

Voltage area	Voltage used for Inline	Product group
SELV	24 V DC	Low-level signal terminals; Inline Block IO modules
Low voltage	120 V AC	Low voltage terminals; AC terminals
	230 V AC	
	400 V AC	Power-level terminals



Observe the safety notes in the following sections when working outside the SELV area.

3.2 Correct usage

Inline Block IO modules and Inline Modular IO terminals should only be used according to the instructions in the terminal-specific data sheets and this user manual. Phoenix Contact accepts no liability if the device is used for anything other than its designated use.

When used in the SELV area:



NOTE: Disregarding this warning may result in malfunction

Do not replace terminals while the power is connected.

Before removing or mounting a terminal, disconnect power to the entire station.

Make sure the entire station is reassembled before switching the power back on.

When used in the low voltage area:



WARNING: Dangerous contact voltage

Do not replace terminals while the power is connected.

Before removing or mounting a terminal, disconnect power to the entire station.

Make sure the entire station is reassembled before switching the power back on.



WARNING: Dangerous contact voltage

Please note that there are dangerous contact voltages when switching circuits that do meet SELV requirements.

When working on the terminals and wiring, always switch off the supply voltage and ensure it cannot be switched on again.

3.3 Notes for Inline Modular IO

3.3.1 Safety notes for use in the low voltage area

Only qualified personnel (qualified electricians or persons instructed in electrical engineering) may work on Inline terminals outside the SELV area.



The instructions given in the terminal-specific data sheets must be followed during installation and startup.

An **electrician** is a person who, because of their education, experience, and instruction, and their knowledge of relevant standards, can assess any required operations and recognize any possible dangers. (Definitions according to DIN VDE 1000-10:1995).

A **person instructed in electrical engineering** is someone who has been instructed by an electrician in their required tasks and the possible dangers caused by incorrect handling and, if necessary, has also been informed of the necessary safety equipment and safety measures. (Definitions according to DIN VDE 1000-10:1995).

3.3.2 Safety notes for electrical equipment used in industrial plants with a 400 V AC voltage



WARNING: Dangerous contact voltage

The electrical power-level terminals for the 400 V AC area and connected machines refer to equipment used in industrial plants. During operation, this equipment has dangerous, live, moving or rotating parts. These can therefore cause considerable damage to health or equipment, e.g., due to the unauthorized removal of protective covers or inadequate maintenance.

- Only qualified personnel may work on the power-level terminals or system (for the definition, see Section 3.3.1 on page 3-2).
- When working on the power-level terminals and the system, you must always keep the operating instructions and other items of product documentation to hand and observe the information therein.
- It is prohibited for unqualified personnel to work on the power-level terminals, on the machine or in their vicinity.

The instructions given in the terminal-specific data sheets must be followed during installation and startup.

The notes on the procedures and the circuit details presented in the terminal-specific data sheets should be understood in a general sense and the relevant application should be tested to see if they apply.

Phoenix Contact cannot guarantee the suitability of the procedures or the circuit suggestions described for the relevant application.

3.3.3 Installation instructions and notes for low voltage terminals



WARNING: Dangerous contact voltage

Please note that there are dangerous contact voltages when switching circuits that do meet SELV requirements.

Connecting and disconnecting the terminals for the 120 V AC and 230 V AC voltage areas is only permitted if the power supply is disconnected.

When working on the terminals and wiring, always switch off the supply voltage and ensure it cannot be switched on again.



WARNING: Dangerous contact voltage in the event of ground faults

(e.g., because the FI circuit breaker has not tripped or the star point connection is "free")

Inline terminals for the 120 V AC and 230 V AC voltage areas should only be operated in grounded AC voltage networks (AC networks).

3.3.3.1 Structure of a 120 V AC/230 V AC area

A 120 V AC/230 V AC area **must** have a power terminal at one end and an end terminal at the other.

I/O terminals for these voltage areas can be used between these terminals. The number of terminals is limited by the system limits of the bus system and the Inline system (see Section 11, "Inline Modular IO: Technical data and ordering data").

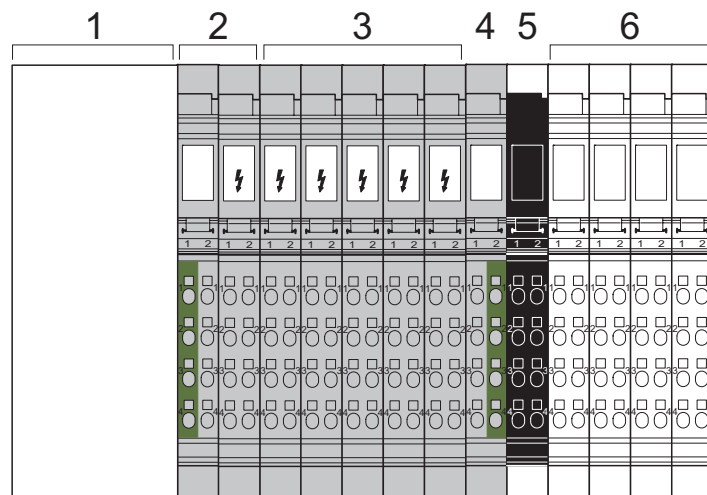

6452A003

Figure 3-1 Typical structure of an Inline station with different voltage areas

- 1 Bus coupler
- 2 Power terminal for the 120 V AC or 230 V AC area
- 3 Various I/O terminals for the 120 V AC or 230 V AC area
- 4 End terminal for the 120 V AC or 230 V AC area
- 5 Power terminal for the 24 V DC area
- 6 Various I/O terminals for the 24 V DC area

3.3.3.2 Fuse protection for a 120 V AC/230 V AC area

Each 120 V AC/230 V AC area must be protected by its own external fuse. Select the rating of the fuse according to the strength of the cable. The maximum fuse value is 8 A. For additional restrictions, please refer to the data sheets for the power terminals.

Important information about voltage areas

3.3.3.3 Connecting the power supply and I/O in the 120 V AC/230 V AC area



WARNING: Dangerous contact voltage

The supply voltage must **only** be provided at the appropriate power terminal.

If you provided voltage to several places in an incomplete Inline station, there would be a danger of touching live parts.

The connecting cables of all actuators and sensors must only be connected to the Inline terminals for the relevant voltage area. The use of external bus bars for group potentials is **not permitted**.

3.3.3.4 Interrupting PE jumpering in the 120 V AC/230 V AC area

The PE jumper begins at the power terminal of the 120 V AC/230 V AC area and, in a complete AC voltage area, ends at the end terminal.

If a terminal is removed from this area, the PE jumper is interrupted.

If the installation instructions have been followed, all subsequent terminals will be disconnected.

3.3.4 Electronics base and connectors for the different voltage areas

Power-level terminals are located in a power housing.

Low-level signal terminals and low voltage terminals are located in the same type of housing, which is referred to as low-level signal housing. An external feature that distinguishes the base and the corresponding connectors of low voltage terminals from the base and connectors of low-level signal terminals is their color:

Table 3-2 Base and connector colors for the different voltage areas

Area	Terminal	Connector	Other differences
Low-level signal (24 V DC)	Green	Green or black	Light color for function identification (e.g., light blue)
Low voltage (120 V AC/230 V AC)	Gray	Gray	Dark color for function identification (e.g., dark blue) with white lightning bolt

3.3.5 Safety mechanisms to prevent incorrect connection of terminals for different voltage areas

3.3.5.1 Protection against the insertion of 24 V DC terminals and power-level terminals in the 120 V AC/230 V AC area

Low-level signal terminals and power-level terminals cannot be snapped-on within a low voltage area because there is no keyway on the right-hand side of the low voltage terminals (120 V AC/230 V AC).



WARNING: Dangerous contact voltage

The power terminals for the 24 V DC area can be inserted in a 120 V AC/230 V AC area. The minimum isolating distance in this case is the distance between two adjacent connectors. This isolating distance is not permitted. Therefore, only use end terminals that are designed for terminating the 120 V AC/230 V AC area.

3.3.5.2 Protection against the connection of 24 V connectors to 120 V AC/230 V AC terminals

The two terminal points for the low voltage I/O terminals are closed using filler plugs. The connectors for low-level signal terminals therefore do not fit on the low voltage terminals.

Exception 1: The low-level signal connectors can be plugged into 120 V AC/230 V AC power terminals.

This connection error has no hazardous effect on the electrical components, but it can lead to system malfunctions.

Only the appropriate connectors should therefore be plugged into the low voltage power terminals.

Exception 2: The low-level signal connectors can be plugged into relay terminals. Because the relay outputs are floating, this connection error has no adverse effects.

3.3.5.3 Protection against the connection of live 120 V AC/230 V AC connectors in the 24 V DC area

If the connectors for the I/O terminals are wired according to the installation instructions, they are disconnected from the power supply when removed.

The following connectors may be live in the low voltage area:

- 1 Connectors of the power terminals for the 120 V AC and 230 V AC areas
- 2 Connectors for relay terminals

These connectors are closed using filler plugs in some places and therefore do not fit on the terminals of the 24 V area.

Important information about voltage areas

3.3.6 Response to the connection of a 120 V AC or 230 V AC terminal in the 24 V DC area

An AC terminal can be inserted in the 24 V DC area. The effects are described in Table 3-3.



A 24 V DC terminal cannot be inserted accidentally in an AC area as these terminals are not mechanically compatible.

Table 3-3 Response to the connection of an AC terminal in the 24 V DC area

AC terminal in the 24 V DC area	Effect/description
AC power terminal in the 24 V DC area	<p>Specified interface between a 24 V DC area and an AC area.</p> <p>The AC power terminal consists of two function parts:</p> <ul style="list-style-type: none"> – The left-hand part interrupts the jumpering of U_S, U_M, GND, and FE – The connections for the power supply and the jumper contacts for L, N, and PE are on the right-hand part
Digital AC output terminal in the 24 V DC area	<p>No direct danger to people.</p> <p>If the output is activated, the Triac output may be forced to trip and no longer switch off because the supply voltage does not pass through zero.</p> <div style="border: 1px solid black; padding: 5px; margin-top: 10px;"> <p>NOTE: Possible malfunction This is likely to be caused by a malfunction of the actuator connected to the relevant output.</p> </div>
Digital AC input terminal in the 24 V DC area	<p>No danger to people or machines.</p> <p>The input does not function due to missing ground.</p>
Relay terminal in the 24 V DC area	<p>No direct danger to people.</p> <p>The module has no diagonal routing, so there is no direct danger from the terminal, even with a 230 V connector. This means that the shortest isolating distance is the distance from one connector to the next. This isolating distance is not permitted. Therefore, insert a distance terminal (order designation IB IL DOR LV-SET) before and after the relay terminal.</p>
AC end terminal in the 24 V DC area	<p>No danger to people or machines.</p> <p>The terminal offers neither diagonal routing nor connector connection.</p>

IL SYS INST UM E

onlinecomponents.com

4 Inline product groups

The following sections provide an overview of the Inline product groups. For specific information about the individual terminals/modules, please refer to the specific data sheets and the individual sections in this manual.











The product range is continuously growing. Additional information can be found in the latest "AUTOMATION" catalog or on the Internet at www.phoenixcontact.com.

4.1 Supported bus systems

Inline devices are available for the following bus systems:

Table 4-1 Bus systems supported by Inline

Bus system		Inline Modular IO	Inline Block IO
PROFINET IO		Yes	Yes
INTERBUS		Yes	Yes
PROFIBUS DP		Yes	Yes
Ethernet IP		Yes	Not at present
Ethernet TCP/IP	Ethernet	Yes	Yes
Modbus/TCP	Modbus	Yes	Yes
Modbus/RTU	Modbus	Yes	Not at present
SERCOS II		Yes	Not at present
SERCOS III		Yes	Yes
DeviceNet™		Yes	Yes
CANopen	CANopen	Yes	Yes
Mechatrolink		Yes	Not at present
Bluetooth		Not at present	Yes

4.2 Inline Modular IO terminals

4.2.1 Scope of supply and transmission speed

Scope of supply

Inline terminals are predominantly available as complete items. This is indicated in the order designation by the extension "-PAC". The following are supplied as standard with a complete item:

- The electronics base
- All required Inline connectors
- All required labeling fields

In the past, Inline terminals were available as stand-alone items without accessories. For a stand-alone item without accessories, the Inline connectors and labeling fields have to be ordered separately.

Local bus transmission speed

It is possible to operate at a transmission speed of 500 kbps or 2 Mbps within an Inline station.

Items designed for 2 Mbps are indicated by the extension "-2MBD" in the order designation. The versions without this extension are designed for 500 kbps.



In the product range, terminals with 500 kbps are basic versions. Some (not all) of the terminals are also available as 2MBD versions. Additional information about the available terminals can be found in the latest "AUTOMATION" catalog or on the Internet at www.phoenixcontact.com.



NOTE:

Use the same transmission speed throughout an Inline station. The station cannot operate otherwise. Make sure that your bus coupler supports this transmission speed in the local bus.

For INTERBUS, a separate bus coupler version is available for each transmission speed. Bus couplers for other bus systems may only support terminals with 500 kbps or even both transmission speeds in the local bus.



For details of which transmission speed your bus coupler can use within the local bus, please refer to the corresponding documentation, the "AUTOMATION" catalog or "AH IL BK IO LIST".

Examples

IB IL 24 DI 2-PAC	500 kbps; complete with accessories (connectors and labeling fields)
IB IL 24 DI 2-2MBD-PAC	2 Mbps; complete with accessories (connectors and labeling fields)
IB IL 24 DI 2	500 kbps; without accessories

Convention for this document

The PAC version for 500 kbps is used in the following examples. However, all information also applies for the versions for 2 Mbps and the versions without accessories.

4.2.2 Example of an Inline station

Figure 4-1 shows a typical Inline station. It contains just a few terminals from the extensive product range. The functions and special features of the individual product groups are described in the sections below.

In addition, Figure 4-1 also shows the structure of the main and segment circuits. This structure can be created using power and/or segment terminals (see "Power, segment, and accessory terminals" on page 4-4).

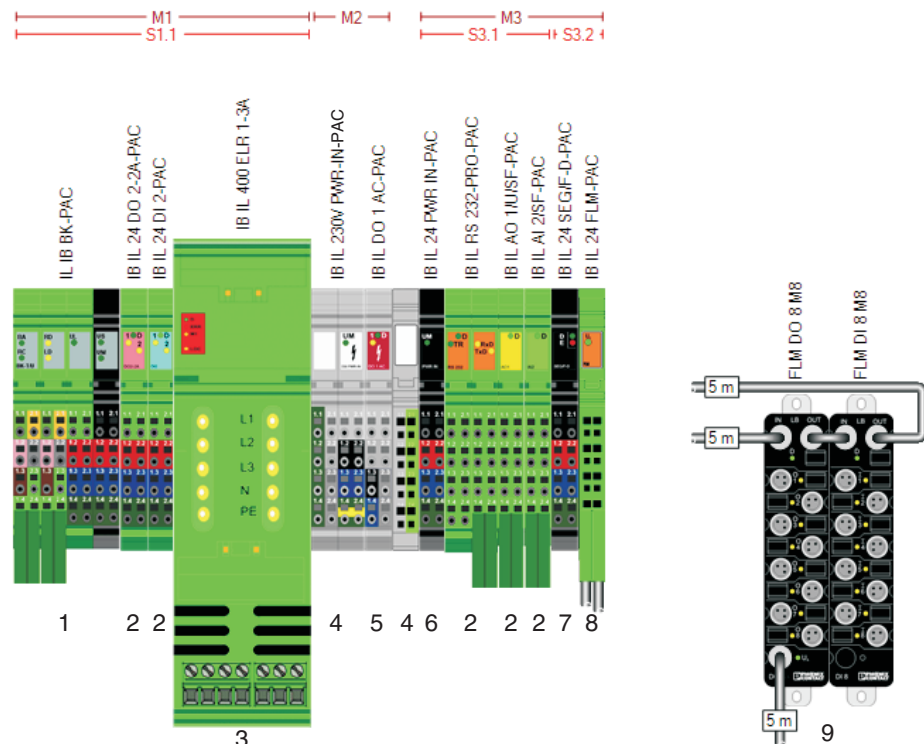

Figure 4-1 Typical Inline station

- 1 Bus coupler (here: with supply voltages supplied)
- 2 I/O terminals for 24 V area
- 3 Power-level terminal
- 4 Power and end terminal for a 230 V area
- 5 Output terminal for 230 V area
- 6 Power terminal for 24 V area
- 7 Segment terminal
- 8 Branch terminal (here: to connect Fieldline Modular M8 devices)
- 9 Fieldline Modular M8 devices

- | | |
|------------|---|
| M1, M2, M3 | Main circuit 1, 2, 3 |
| S1.1 | Segment circuit 1 in main circuit 1 |
| S3.1, S3.2 | Segment circuit 1 and 2 in main circuit 3 |

4.2.3 Bus couplers and terminals with remote bus branch

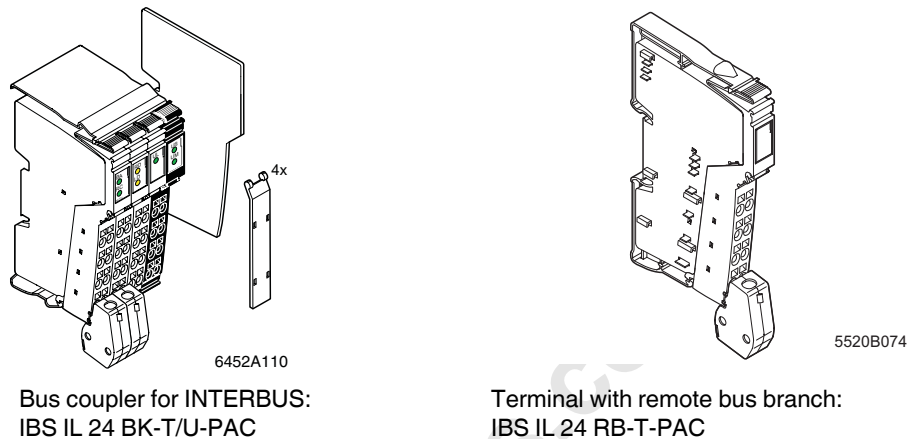

Figure 4-2 Example: Bus coupler and terminal with remote bus branch

4.2.3.1 Bus coupler

A bus coupler is required to connect an Inline station to a bus. Bus couplers are available for various bus systems (see Table 4-1).



The bus couplers are described in detail in a separate document.
Not all Inline terminals can be used with every bus coupler. For an overview of the compatibility between Inline terminals and bus couplers for various bus systems, please refer to "AH IL BK IO LIST".

4.2.3.2 Terminals with remote bus branch

A terminal with remote bus branch can only be used in an INTERBUS system.



For more detailed information about this, please refer to the IB IL SYS PRO UM E user manual or the data sheet for the terminal with remote bus branch.

4.2.4 Power, segment, and accessory terminals



For more detailed information about the voltages used within an Inline station, please refer to "Circuits and provision of supply voltages" on page 7-1.

4.2.4.1 Overview of power and segment terminals

Power terminals and segment terminals are available to supply the station with I/O voltage. The segment terminals extend the power terminals. The segment terminals make it possible to create different segments within a main circuit. Different types can be used to meet your requirements.

Table 4-2 Overview of power and segment terminals

Designation	Type	Supply/provision	Fuse	Diagnostics (bus device)	Fused area	
IB IL 24 PWR IN-PAC	Power terminal	U_M/U_S	No	No	None	
IB IL 24 PWR IN/M			No	No	None	
IB IL 24 PWR IN/F-PAC			Yes	No	Main circuit	
IB IL 24 PWR IN/2-F-PAC			Yes	No	Main circuit and segment circuit	
IB IL 24 PWR IN/F-D-PAC			Yes	Yes (500 kbps)	Main circuit	
IB IL 24 PWR IN/2-F-D-PAC			Yes	Yes (500 kbps)	Main circuit and segment circuit	
IB IL 24 PWR IN/2-F-D-2MBD-PAC			Yes	Yes (2 Mbps)	Main circuit and segment circuit	
IB IL 24 PWR IN/2F-DF-PAC			Yes	Yes (500 kbps)	Main circuit and segment circuit	
IB IL 24 PWR IN/2F-DF-2MBD-PAC			Yes	Yes (2 Mbps)	Main circuit and segment circuit	
IB IL 24 PWR IN/R-PAC			U_{24V} (U_L/U_{ANA})/ U_M / U_S	No	No	None
IB IL 24 PWR IN/PS-PAC		No		No	None	
IB IL 120 PWR IN-PAC		L	L	No	No	None
IB IL 230 PWR IN-PAC				No	No	None
IB IL 230 PWR IN/F-D-PAC	Yes			Yes (500 kbps)	Main circuit	
IB IL 24 SEG-PAC	Segment terminal	U_S	No	No	None	
IB IL 24 SEG/F-PAC			Yes	No	Segment circuit	
IB IL 24 SEG/F-D-PAC			Yes	Yes (500 kbps)	Segment circuit	
IB IL 24 SEG-ELF-PAC			Yes (electronic)	Yes (500 kbps)	Segment circuit	
IB IL 24 SEG-ELF-2MBD-PAC			Yes (electronic)	Yes (2 Mbps)	Segment circuit	

- U_M Main voltage
- U_S Segment voltage
- U_{24V} 24 V supply, generated from voltages U_L and U_{ANA}
- U_L Communications power
- U_{ANA} Analog voltage



NOTE: Consequential damage

Protect the power supply externally, regardless of the power and/or segment terminal used.



Terminals that are not bus devices can be used in a local bus with 500 kbps as well as a local bus with 2 Mbps.

4.2.4.2 Power terminals

A power terminal is used to supply the required voltages to the internal station potential jumpers. Several power terminals can be used in one station. This means that different circuits can be electrically isolated and areas with different voltages can be created within the station (e.g., 24 V DC and 230 V AC).

All power terminals are used to supply the main voltage and/or segment voltage.

A 24 V supply voltage is also supplied at the IB IL 24 PWR IN/R-PAC and IB IL 24 PWR IN/PS-PAC terminals, from which the communications power U_L and the analog voltage U_{ANA} are generated. These terminals are mainly designed to boost the communications power and analog voltage when the maximum current carrying capacity of the potential jumpers for U_L/U_{ANA} or the maximum current carrying capacity of the bus coupler for U_L/U_{ANA} is reached.

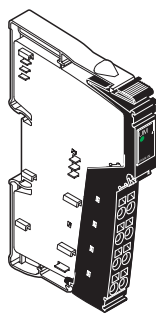

5520A013

Figure 4-3 Example of a power terminal: IB IL 24 PWR IN-PAC

Voltage areas

Depending on the power terminal, it is possible to work with 24 V DC, 120 V AC or 230 V AC within an Inline station.

To utilize different voltage areas within a station, a new power terminal must be used for each area.



WARNING: Dangerous contact voltage

When the power terminal is removed, the metal contacts are freely accessible. With 120 V AC or 230 V AC power terminals, it should be assumed that dangerous contact voltage is present. You **must** disconnect power to the station **before removing** a terminal.

If these instructions are not followed, there is a danger of damage to health or even of a life-threatening injury.



Observe safety notes

Observe the notes provided in "Important information about voltage areas" on page 3-1 when using voltages outside the SELV area.

Inline product groups

Potential jumpers	The power terminal interrupts all potential jumpers for the voltages to be reinjected, and recreates all potential jumpers (see also "Electrical potential and data routing (Inline Modular IO)" on page 7-1).
Carrying capacity of the jumper contacts	The maximum current carrying capacity of the jumper contacts on the side is specified in "Current and voltage distribution" on page 7-12.
Electrical isolation	The power terminal is used to create electrically isolated I/O areas within a station.
Functional earth grounding (24 V DC)	<p>24 V power terminals are connected to functional earth ground when they are snapped onto the grounded DIN rail via the FE spring on the bottom of the terminal. This spring is connected to the FE potential jumper and to the terminal points for an FE connection.</p> <p>If the previous terminal is a 24 V terminal, the power terminal is connected to the FE potential jumper of the station when it is snapped onto this terminal.</p>
Required additional functional earth grounding (24 V DC)	A 120 V AC and 230 V AC voltage level area interrupts the FE jumper, which is connected to FE via the additional functional earth grounding at the bus coupler. A 24 V DC power terminal that is at a different voltage area must therefore be reconnected to functional earth ground via the FE connection to ensure reliable functional earth grounding of the station even if the FE spring is dirty or damaged. Connect the terminal points for the FE connection to a grounded PE terminal (see "Grounding concept" on page 9-8).
Protective earth grounding (120 V AC/230 V AC)	The PE terminal point of the power connector connects the 120 V AC and 230 V AC power terminals to protective earth ground (PE). This terminal point is connected to the PE potential jumper, which is led through the entire 120 V AC or 230 V AC voltage area.

Additional documentation



For more detailed information about the function, properties, and wiring of the individual terminals, please refer to the terminal-specific documentation.

4.2.4.3 Segment terminals

Segment terminals can only be used in the 24 V DC area. Segment terminals can be used to create partial circuits (segment circuits) within the main circuit.

On segment terminals without a fuse, the connection between the main circuit U_M and the segment circuit U_S must be established using a jumper or a switch. Segment terminals with a fuse establish this connection automatically.

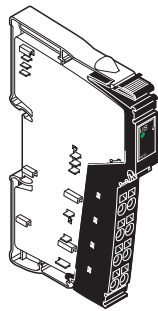

5520A014

Figure 4-4 Example of a segment terminal: IB IL 24 SEG-PAC

U_M

The potential jumper for the main circuit U_M is not interrupted in the segment terminal. The potential for the segment circuit U_S is tapped from the potential jumper at the segment terminal.

U_S

The segment terminal interrupts the segment circuit U_S in the potential jumper of the previous terminal.

For more detailed information about the supply voltages, please refer to "Circuits and provision of supply voltages" on page 7-1.

Carrying capacity of the jumper contacts

The maximum current carrying capacity of the jumper contacts on the side is specified in "Current and voltage distribution" on page 7-12.

Functional earth grounding

The terminal is connected to functional earth ground when it is snapped onto the grounded DIN rail via the FE spring on the bottom of the terminal. This spring is connected to the FE potential jumper and to the terminal points for an FE connection.

When snapped onto the previous terminal, the segment terminal is connected to the FE potential jumper of the station.

Additional documentation



For more detailed information about the function, properties, and wiring of the individual terminals, please refer to the terminal-specific documentation.

4.2.4.4 Accessory terminals

Potential distributor terminals and distance terminals are available as accessory terminals.

Potential distributor terminals (for GND and 24 V) are designed for the economical return wiring of sensor and actuator cables when using Inline terminals with 1-wire termination.

The distance terminal set creates the specified creepage distance when using AC terminals. Both distance terminals interrupt the potential jumpers for the main voltage, segment voltage, ground, and functional earth ground.

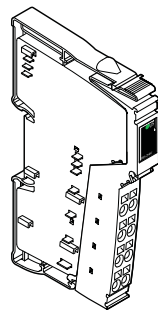

6452A108

Figure 4-5 Example of a potential distributor terminal:
IB IL PD 24V-PAC

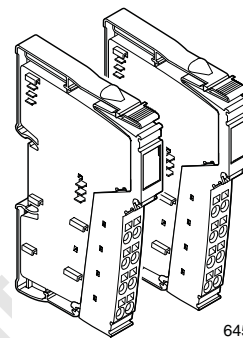

6452A109

Figure 4-6 Distance terminal set:
IB IL DOR LV-SET-PAC

Additional documentation



For more detailed information about the function, properties, and wiring of the individual terminals, please refer to the terminal-specific documentation.

4.2.4.5 Supply and segmentation options

Figure 4-7 provides an overview of supply and segmentation. For more detailed information, please refer to "Electrical potential and data routing (Inline Modular IO)" on page 7-1.

IL SYS INST UM E

Supply and segmentation

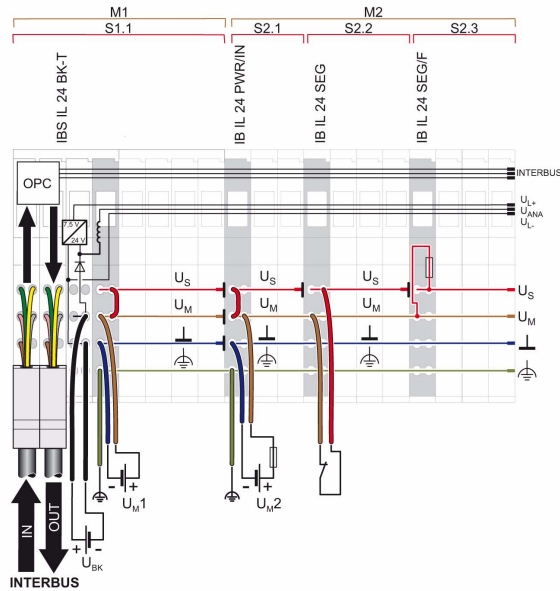

Segment terminals can be used to create different segment circuits within a 24 V area of an Inline station.

Structure of an AC area

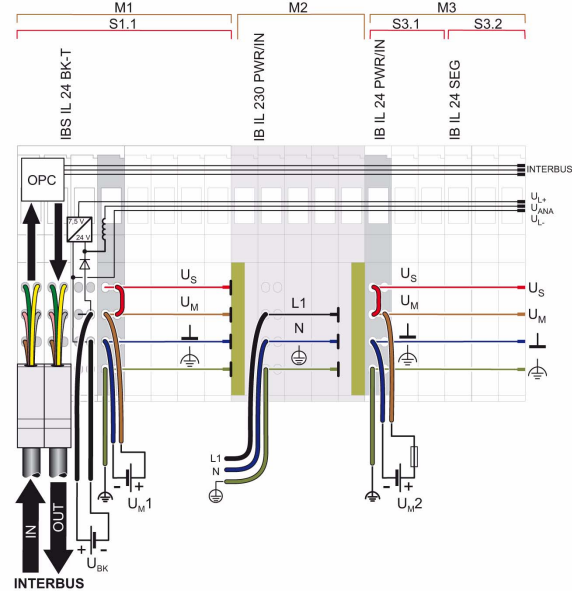

Special AC power and segment terminals can be used to create AC areas within an Inline station.

Integration of power-level terminals

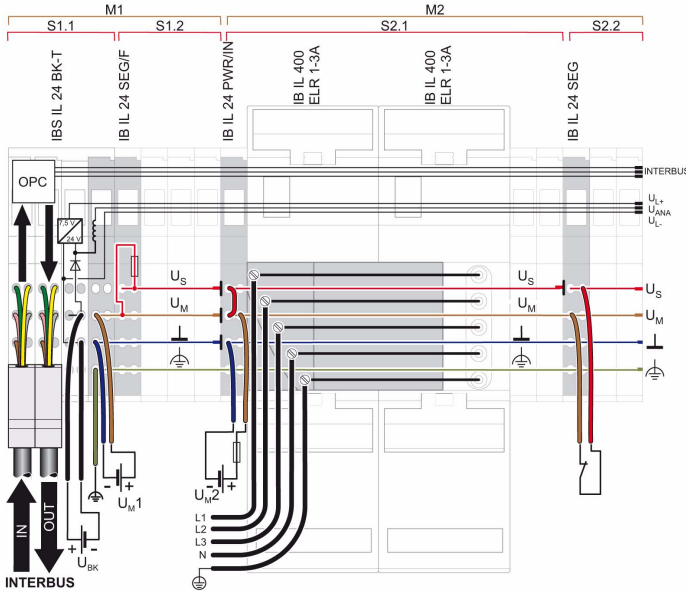

A 400 V power bus is supplied at the first power-level terminal and jumped further.

Figure 4-7 Supply and segmentation options

4.2.5 I/O terminals

Functions

Terminals with different functions are available for **low-level signals**. These include the following terminals, for example: The text in brackets indicates the function according to the order designation.

- Digital input and output terminals (DI, DO)
- Analog input and output terminals (AI, AO)
- Relay terminals (DOR)
- Temperature measurement terminals (TEMP)
- Communication terminals
 - Communication terminals with serial interface (RS232, RS485/422)
 - Inline/AS-i master (ASI MA)
 - DALI terminals (DALI)
- Position detection terminals (INC-IN, IMPULSE-IN, SSI-IN)
- Terminals for open and closed-loop control
 - Function terminals (PWM, CNT)
 - Positioning terminals (SSI, INC)
 - Temperature controller terminals (TEMPCON)

Digital input and output terminals and relay terminals are available for the **low voltage area**.

These terminals are available in different sizes. This enables you to set up the station in a modular way so that it meets your application requirements.

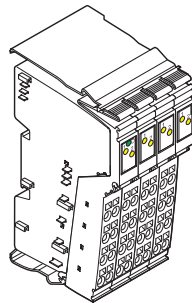

5520A015

Figure 4-8 Example of a digital input terminal: IB IL 24 DI 8-PAC

Protection

Overload protection of the system is provided centrally by a fuse in the power terminal or by an external fuse provided by the operator. The rating of the preconnected fuse must be such that the maximum load current is not exceeded. For the maximum permissible load current of an I/O terminal, please refer to the terminal-specific data sheet.

Carrying capacity of the jumper contacts

The maximum current carrying capacity of the jumper contacts on the side is specified in "Current and voltage distribution" on page 7-12.

Grounding (FE or PE)

Connection to functional earth ground (24 V DC area) or protective ground (120 V AC or 230 V AC area) is established via the corresponding potential jumpers when the terminal is snapped onto the previous terminal.

IL SYS INST UM E

- Voltage areas** I/O terminals are available for different voltage areas. Depending on the power terminal, it is possible to operate with 24 V DC, 120 V AC or 230 V AC.
To utilize different voltage areas within a station, a new power terminal must be used for each area.
- Shielding** Inline shield connectors are available for connecting shielded cables.
- Parameterization** Some terminals can be parameterized via process data or PCP. For detailed information, please refer to the terminal-specific data sheet.
- Data formats** The measured values and the corresponding output values of analog and temperature measurement terminals can be represented in different data formats depending on the terminal used and its configuration. These formats are listed in the relevant terminal-specific data sheets.
- Diagnostics** The scope of the diagnostics depends on the terminal used and is specified in the relevant terminal-specific data sheet.

Additional documentation



For more detailed information about the function, properties, wiring, and parameterization of the individual terminals, please refer to the terminal-specific documentation.

4.2.6 Power-level terminals

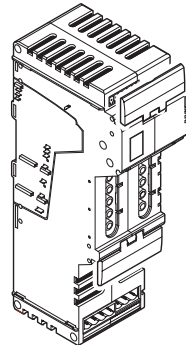

5520A128

Figure 4-9 Power-level terminal

Different power-level terminals are available for direct switching, protection, and monitoring of three-phase standard motors via a bus system:

- Power-level terminal as electronic direct starter for motors up to 1.5 kW/400 V AC
- Power-level terminal as electromechanical direct starter for motors up to 3.7 kW/400 V AC
- Power-level terminal as electronic reversing load starter for motors up to 1.5 kW/400 V AC

Features

- Electronic motor protection
- Motor current parameterization via a bus system
- Motor current monitoring
- Quick shutdown
- Mains voltage up to 400 V AC or 520 V AC, maximum (without tolerance in electromechanical versions)
- Nominal output power of 1.5 kW to 3.7 kW depending on the version
- Hand-held operator panel mode
- Can be extended with brake function as an option
- Thermal motor monitoring using connected thermistor terminal

Connections

Connections for the mains supply input, remote cabling, motor output, hand-held operator panel mode, and a brake are available on a power-level terminal.

Carrying capacity of the jumper contacts

The maximum current carrying capacity of the jumper contacts on the side is specified in "Current and voltage distribution" on page 7-12.

Protective earth grounding (PE)

The power-level terminal is connected to protective earth ground via the mains connection.

Voltage area

Power-level terminals must be installed in a 24 V DC area within an Inline station. Operation in a different voltage area is not permitted.

Additional documentation



For more detailed information about the function, properties, wiring, and parameterization of the individual terminals, please refer to the terminal-specific documentation.

4.2.7 Servo amplifier

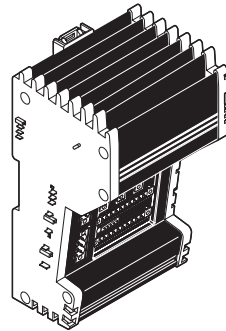

6976A000

Figure 4-10 Servo amplifier

Various servo amplifiers are available for controlling (position, speed or torque control) DC motors with and without brushgears via a bus system:

Features

- Can be used as a position, torque or speed controller depending on the version
- For DC motors with or without brushgears depending on the version
- 4 quadrant function
- External brake chopper
- Short-circuit-proof motor output
- Nominal voltage of 12 V to 48 V
- Motor current of up to 10 A

Connections

The following connections are available on a servo amplifier:

- Power supply
- Motor

In addition, the following connections may be available:

- Limit and home position switches
- Incremental encoder
- Hall sensor

Carrying capacity of the jumper contacts

The maximum current carrying capacity of the jumper contacts on the side is specified in "Current and voltage distribution" on page 7-12.

Functional earth grounding (FE)

Connection to functional earth ground is established via the corresponding potential jumpers when the servo amplifier is snapped onto the previous terminal.

Voltage area

Servo amplifiers must be installed in a 24 V DC area within an Inline station. Operation in a different voltage area is not permitted.

Additional documentation



For more detailed information about the function, properties, wiring, and parameterization of the individual terminals, please refer to the terminal-specific documentation.

4.2.8 Safety terminals

4.2.8.1 Bus-independent safety terminals

IB IL 24 SAFE 1-PAC

The IB IL 24 SAFE 1-PAC safety terminal is designed for use within the 24 V area of an Inline station. It can act as an emergency stop safety relay, a safety door monitor or secondary switchgear for control strips and safety mats.

The safety terminal can be used to achieve safety functions with requirements up to category 4 according to standard EN 954-1.

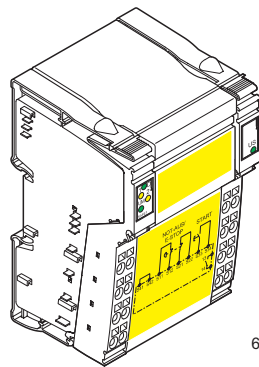

6452A037

Figure 4-11 Safety terminal: IB IL 24 SAFE 1-PAC

Safety-related segment circuit

The safety terminal can be used to create a safety-related segment circuit.

The structure of the safety-related segment circuit in the Inline system is such that actuators/controlled devices, which are connected to output terminals, can be switched separately via the bus system and can be switched off safely on a safety demand to the pre-connected safety terminal.

The safety-related segment circuit starts at a safety terminal and finishes at the last terminal before another power supply unit or at the end of the station. Only Inline terminals that are specifically designed for the safety-related segment circuit may be used. They are listed in the "Safety-related segment circuit" application note, AH EN IL SAFE.

IB IL 400 SAFE 2

The IB IL 400 SAFE 2 terminal is available as a contact extension for this safety terminal. It is used for the safe disconnection of the 400 V three-phase supply for the subsequent power-level terminals.



For information about the safety terminals, please refer to the terminal-specific data sheet.

This includes, for example:

- Method of operation
- Safety notes to be observed
- Modules permitted within safety-related segment circuits
- Requirements regarding wiring
- Application examples

4.2.8.2 Safety terminals in a bus system with a safe protocol

In addition to the use of bus-independent, conventional safety terminals (such as IB IL SAFE 1-PAC) in an Inline station, safety terminals can also be used in a bus system with a safe protocol (INTERBUS Safety, PROFIsafe). In this type of bus system, the safe data is transmitted between the safe controller and the safety modules via the bus using a safe protocol. This means that the same cable is used for both safety-related communication and standard communication.

INTERBUS Safety

INTERBUS Safety can be used to achieve safety functions with the following requirements:

- Up to category 4 according to standard EN 954-1
- Up to SIL 3 (safety integrity level) according to standards EN 61508 and EN 62061
- Up to PL e (performance level) according to standard EN ISO 13849-1

INTERBUS Safety thus meets the highest safety requirements for the process and manufacturing industry.

Within the Inline product range, the following safety terminals are available for INTERBUS Safety, for example:

IB IL 24 SDIO 4/4/1, IB IL 24 SDI 8-PAC, IB IL 24 SDO 8-PAC, IB IL 24 SDOR 4-PAC

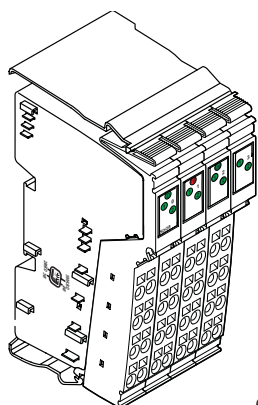

6452A053

Figure 4-12 Safety terminal: IB IL 24 SDI 8-PAC



For more detailed information, please refer to the terminal-specific user manuals and the "INTERBUS Safety system description" user manual, UM EN INTERBUS-SAFETY SYS.

PROFIsafe

Safety terminals for PROFIsafe are in preparation.

PROFIsafe is a profile for PROFIBUS and PROFINET certified according to IEC 61508.

PROFIsafe can be used to achieve safety functions with the following requirements:

- Up to category 4 according to standard EN 954-1
- Up to SIL 3 according to standard IEC 61508

PROFIsafe thus meets the highest safety requirements for the process and manufacturing industry.

4.2.9 Programmable terminals (control terminals)

A CPU and Inline Controller are available as control terminals with distributed intelligence.

The Inline Controller is part of the Remote Field Controller (RFC) group. Using an Inline Controller, the Inline station becomes a distributed control system. The Inline Controller integrates an IEC 61131-programmable PLC CPU in the Inline system. The Inline Controller enables direct signal processing of the distributed I/O points. The Inline Controller also enables the creation of independent subnetworks, which process automation tasks autonomously.

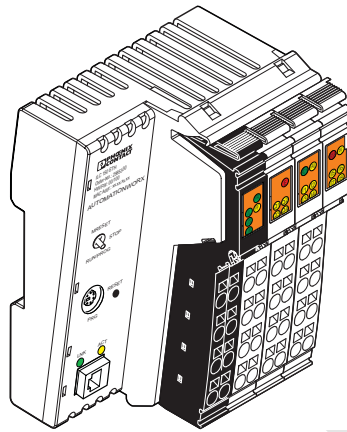

6452A054

Figure 4-13 Example of an Inline Controller: ILC 150 ETH



For more detailed information, please refer to the terminal-specific data sheets and user manuals.

4.2.10 Branch terminals

4.2.10.1 Branch terminal for integrating a Fieldline Modular local bus in an Inline station

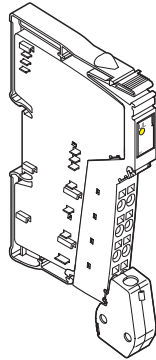

6452B017

Figure 4-14 Example of a branch terminal: IB IL 24 FLM-PAC

These branch terminals can be used to integrate sensors and actuators in close proximity to the station, which are connected to the Fieldline Modular M8 or M12 local bus with IP65/67 protection, in your bus system.

The terminal converts the physical transmission method of the Inline local bus to the physical transmission method of the Fieldline Modular local bus.



For additional information, please refer to the terminal-specific data sheet and the documentation for Fieldline Modular.

4.2.10.2 Local bus extension (jumping between two rows)

An Inline station can be extended by one or more rows. A combination of an IB IL 24 FLM-PAC branch terminal and an IB IL 24 LSKIP-PAC local bus extension terminal is used for this.

The branch terminal is installed at the end of a row of an Inline station and the local bus extension terminal is installed at the start of the following row.

The data is transmitted between the two terminals via the RS-422 protocol.

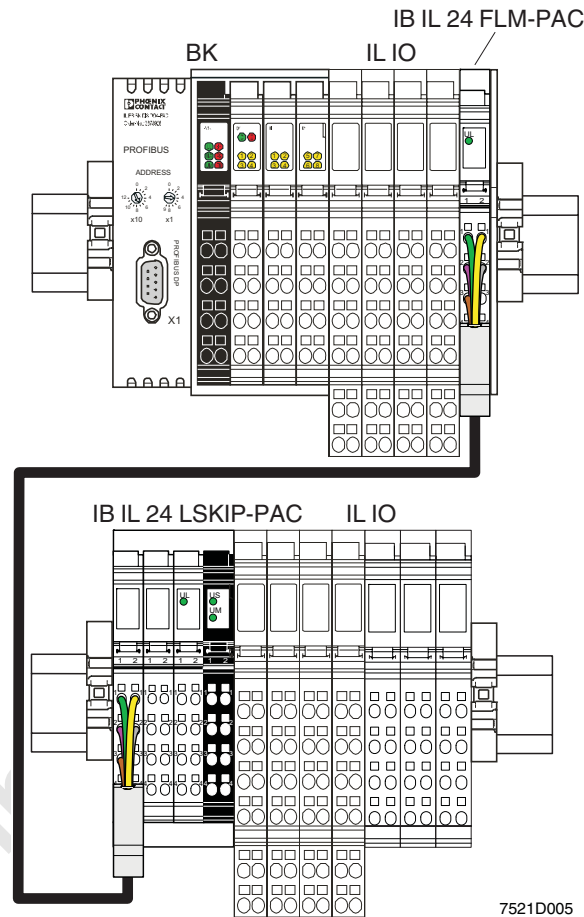
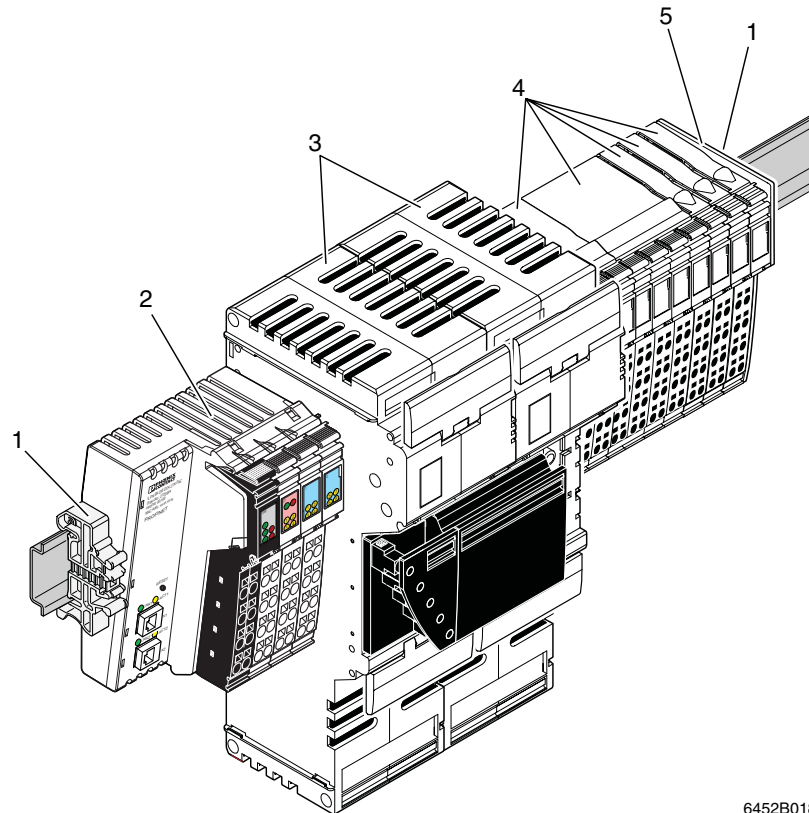

Figure 4-15 Example: Jumping between two rows within an Inline station

4.2.11 Typical structure of an Inline Modular IO station



6452B018

Figure 4-16 Example station with power-level terminals and 24 V DC terminals

The example Inline station shown in Figure 4-16 consists of the following elements:

- 1 End clamps
- 2 Bus coupler (example)
- 3 Power-level terminals
- 4 Terminals for the 24 V DC area (e.g., I/O terminal)
- 5 End plate (end of the station)

4.3 Inline Block IO modules

Block IO modules are available for inputting and/or outputting digital and analog signals to various bus systems (see Table 4-1).

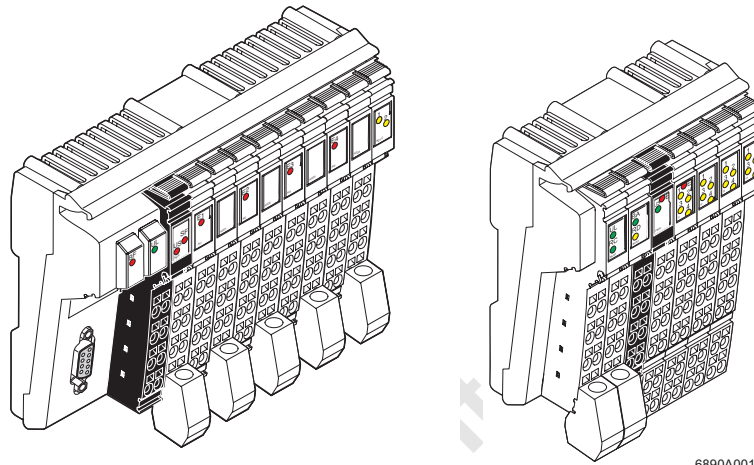

Module for PROFIBUS with four analog inputs and two analog outputs: ILB PB AI4 AO2

Module for INTERBUS with 16 digital inputs: ILB IB 24 DI16

Figure 4-17 Example: Modules of the Inline Block IO product range

Scope of supply

Inline Block IO modules are available as complete items. The following are supplied as standard with a complete item:

- The electronics base
- All required Inline connectors

Bus system

Inline Block IO modules are available for various bus systems (see Table 4-1).

Power supply

All the required voltages are supplied at each individual Inline Block IO module.

Voltage areas

Inline Block IO modules are available for the 24 V DC voltage area.

Functions

Inline Block IO modules are available with various functions. These include the following terminals, for example: The text in brackets indicates the function according to the order designation.

- Digital input and output terminals (DI, DO, DIO)
- Analog input and output terminals (AI, AO)

Protection

Overload protection of the system must be provided by the operator. The rating of the preconnected fuse must be such that the maximum load current is not exceeded. For the maximum permissible load current of an I/O module, please refer to the module-specific data sheet.

IL SYS INST UM E

Grounding (FE)

All Inline Block IO modules have an FE spring (metal clip) on the bottom of the electronics base. This spring establishes an electrical connection to the DIN rail. Use grounding terminals to connect the DIN rail to protective earth ground. The module is grounded when it is snapped onto the DIN rail.

To ensure reliable functional earth grounding of the module even when the DIN rail is dirty or the metal clip is damaged, Phoenix Contact also recommends grounding the module via one of the FE terminal points of a power connector.

Shielding

Shield connectors are available for connecting shielded cables.

Parameterization

Some modules can be parameterized via process data or PCP. For detailed information, please refer to the module-specific data sheet.

Data formats

The measured values and the corresponding output values of analog modules can be represented in different data formats depending on the module used and its configuration. These formats are listed in the relevant module-specific data sheets.

Diagnostics

The scope of the diagnostics depends on the module used and is specified in the relevant module-specific data sheet.

Additional documentation



For more detailed information about the function, properties, wiring, and parameterization of the individual modules, please refer to the terminal-specific documentation.

5 Structure and dimensions

5.1 Structure and dimensions of Inline Modular IO terminals

5.1.1 Basic structure of terminals in the 24 V DC and 120 V AC/230 V AC areas

Regardless of the function and design width, an Inline terminal for these voltage areas consists of the electronics base and the snap-on connector (Inline connector).

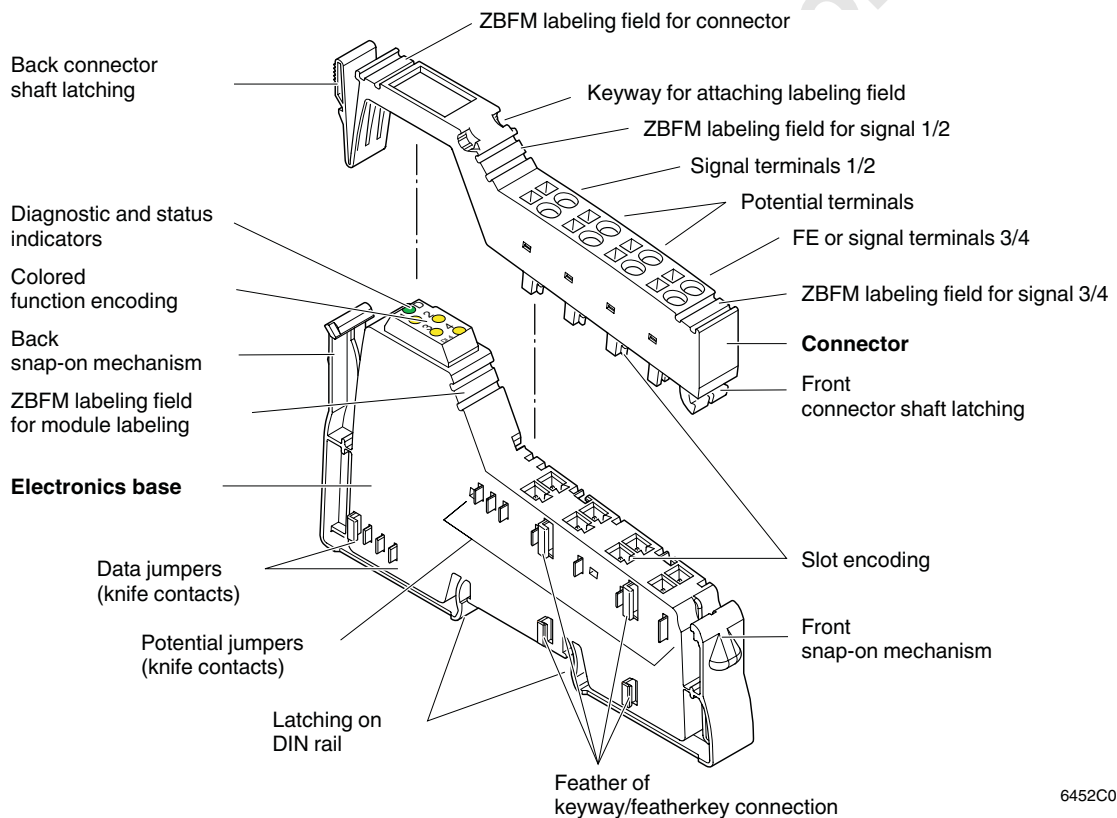

6452C011

Figure 5-1 Basic structure of an Inline Modular IO terminal

ZBFM: Zack marker sheets, flat
(See also "Function identification and labeling" on page 5-5)



The components required for labeling are listed in the Phoenix Contact "CLIPLINE" catalog.

5.1.2 Electronics base

The electronics base holds the entire electronics for an Inline terminal and the potential and data routing.

Potential and data routing

Potential and data routing are located in the base. As all terminals are snapped onto the DIN rail, the position of the interfaces between the terminals in relation to the DIN rail is the same for all terminals. The advantage of this is that terminals of different sizes can be integrated into the station.

The knife contacts are located on the left-hand side of the terminal (shown in Figure 5-1). They snap into the featherkeys of the next terminal on the left when the station is mounted.

The type of routing contacts (i.e., potential or data) that are on each terminal depends on the function of the terminal and is shown in the circuit diagram of the relevant terminal-specific data sheet.

Snap-on mechanism/latching

Pressing the front and back snap-on mechanism at the same time releases the latching, enabling the terminal to be removed by pulling it straight back from the DIN rail (see "Basic information about mounting" on page 9-2).

Keyway/featherkey connection

The featherkeys are on the left-hand side of the terminal (Figure 5-1). They snap into the keyways of the next terminal on the left when the terminal is mounted on the DIN rail. The featherkeys are also referred to as locking clips and the keyways as guideways.

Base colors

The base and the appropriate connectors for the different voltage areas are of different colors (see "Electronics base and connectors for the different voltage areas" on page 3-5).

5.1.3 Connectors for terminals in the 24 V DC and 120 V AC/230 V AC areas

The I/O or supply voltages are connected using a pluggable connector. For more detailed information about the Inline connectors, please refer to Section 6, "Inline connectors".

5.1.4 Basic structure of power-level terminals

Power-level terminals are located in a power housing.

The power housing consists of the following parts:

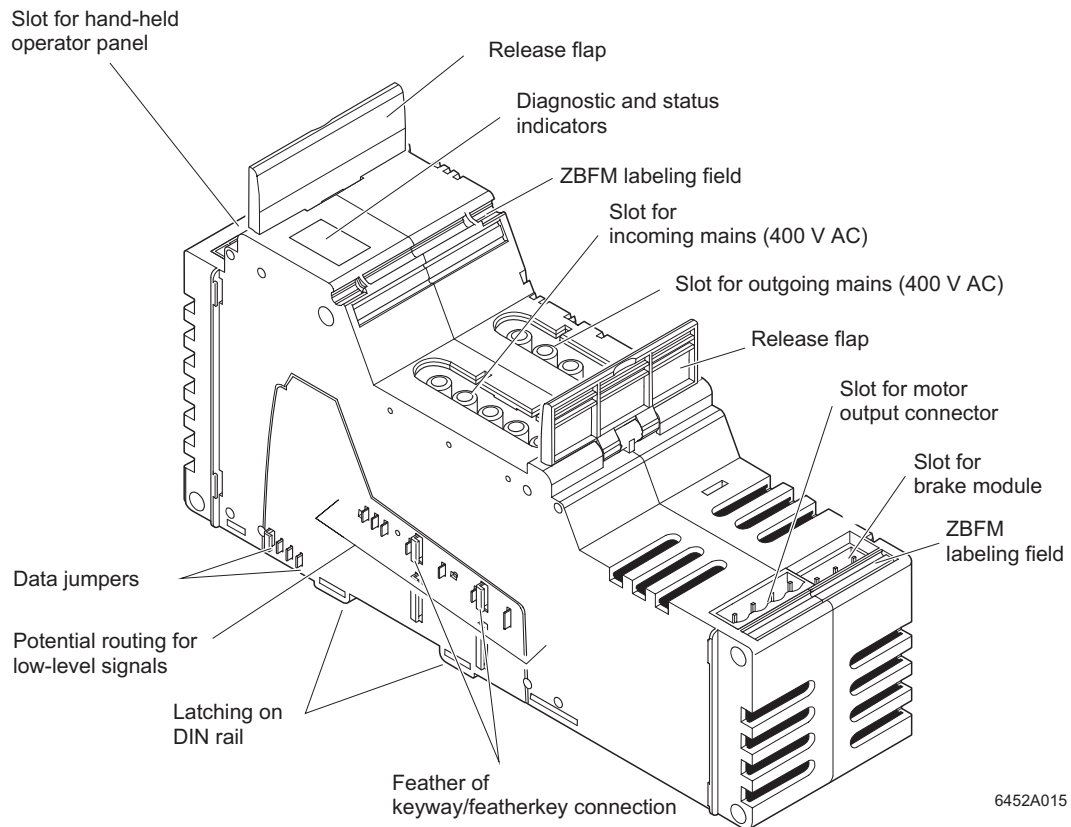

Figure 5-2 Basic structure of Inline housing for power-level terminals

ZBFM: Zack marker sheets, flat
(See also "Function identification and labeling" on page 5-5)



The components required for labeling are listed in the Phoenix Contact "CLIPLINE" catalog.

IL SYS INST UM E

The entire electronics for the Inline power-level terminal, the potential routing for the 24 V DC area, and the data routing are located in the power housing.

Potential and data routing The potential and data jumpers that are led through the 24 V DC terminals are not interrupted by the power-level terminals. For more detailed information about the jumpers, please refer to "Electrical potential and data routing (Inline Modular IO)" on page 7-1.

Release flaps Remove the power-level terminal from the DIN rail by pulling both release flaps (see "Mounting/removing power-level terminals" on page 9-19).

Keyway/featherkey connection The featherkeys are on the left-hand side of the terminal (Figure 5-2). They snap into the keyways of the next terminal on the left when the terminal is mounted on the DIN rail.

5.1.5 Connectors for power-level terminals

The mains voltage, motor output, brake module, hand-held operator panel mode, and the enable power level/24 V isolation functions are connected via connectors.

**Power connector/
power bridge/
cover** A power connector is available for supplying the mains voltage (IB IL 400 CN-PWR-IN).
A power bridge is available for forwarding the mains voltage between power-level terminals (IB IL 400 CN-BRG).
A cover is available for covering unused connections for the 400 V mains connection of the Inline power-level terminals (IB IL 400 CN-COV).

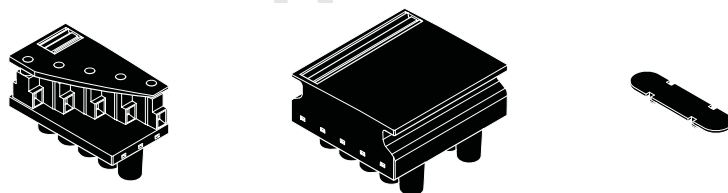

6452A119

Figure 5-3 Power connector, power bridge, and cover

Other connectors All other connectors are connected using COMBICON or MINI-COMBICON connectors (see Phoenix Contact "AUTOMATION" catalog).

5.1.6 Function identification and labeling

Housing

The basic fields of application for Inline Modular IO terminals can be identified by their housing type or color.

Table 5-1 Field of application and housing

Housing type	Housing color	Connector color	Field of application	
Low-level signal housing	Green	Green	Low-level signal (24 V DC)	All functions except supply, safety, DALI
		Black	Low-level signal (24 V DC)	Supply, segmentation
	Yellow	Yellow	Low-level signal (24 V DC)	Safety
	Gray	Gray	Low-level signal (24 V DC)	DALI
			Low voltage (120 V AC/230 V AC)	I/O, supply
Power housing	Green		Power	

Function identification

The area for the diagnostic and status indicators on the terminals is color-coded to enable visual identification of the functions (1 in Figure 5-4).

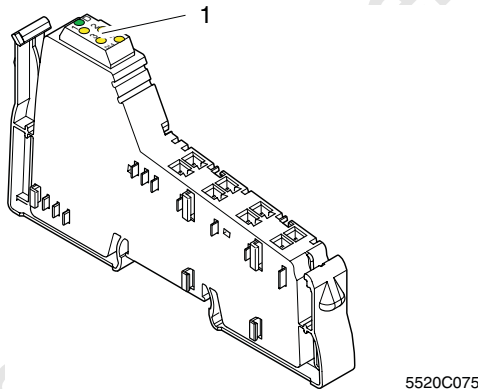

Figure 5-4 Function identification

The following colors indicate the functions:

Table 5-2 Color-coding of terminal function

Color	Terminal function
Gray	Bus couplers, terminals with remote bus branch
24 V DC area	
Black	Supply/segmentation
Light blue, blue	Digital input
Pink, red	Digital output
Light green, green	Analog input, temperature recording
Light yellow, yellow	Analog output
Orange	Open and closed-loop control, communication, position detection, programmable terminals

Table 5-2 Color-coding of terminal function

Color	Terminal function
120 V AC/230 V AC area	
White	Distance
White with lightning bolt	Supply
Dark blue with lightning bolt	Digital input
Dark red with lightning bolt	Digital output

Identification of transmission speed

Terminals with a transmission speed of 500 kbps have solid color-coding. Terminals with a transmission speed of 2 Mbps are identified by a white stripe at the level of the D LED.

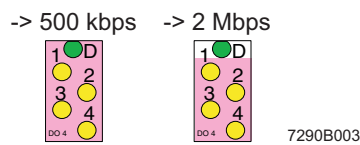

Figure 5-5 Identification of transmission speed

5.1.7 Housing dimensions of terminals in the 24 V DC and 120 V AC/230 V AC areas

Today, small I/O stations are frequently installed in 80 mm standard control boxes. Inline terminals are designed so that they can be used in this type of control box.

The terminal housing dimensions are determined by the dimensions of the electronics base and the dimensions of the connector.

The width of the terminal depends on the electronics base used (housing).

When a connector is plugged in, each terminal has a depth of 72 mm.

The height of the terminal depends on the connector used and is a maximum of 141 mm.

For the dimensions of the terminals, please refer to the relevant module-specific data sheet.

Structure and dimensions

5.1.7.1 Dimensions of the electronics base with possible connectors

**BK IO housing,
example:
IL xx BK D18 DO4 2TX-PAC
ILC 150 ETH**

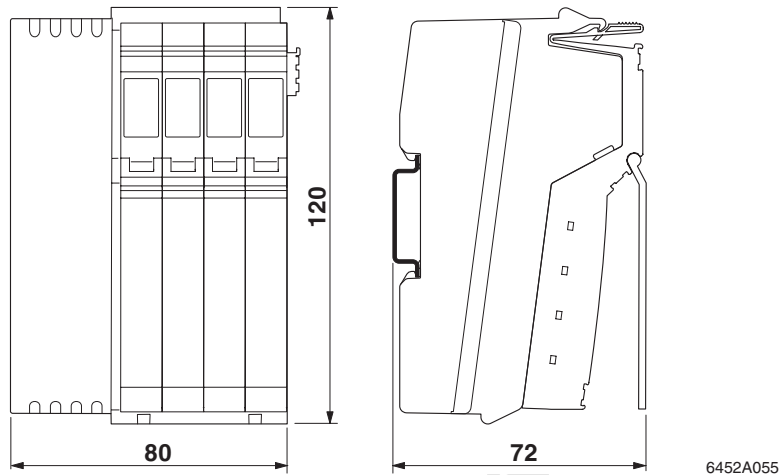

Figure 5-6 Dimensions of BK IO housing (in mm)

**Container housing,
example:
IBS IL 24 BK-LK-PAC
IL PB DP/V1-PAC**

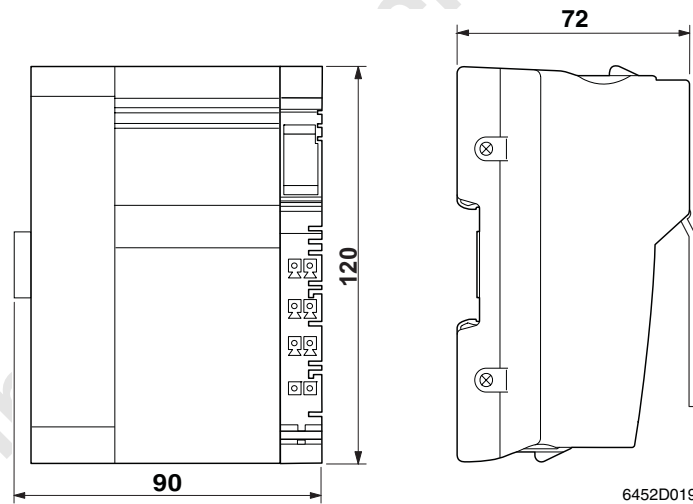
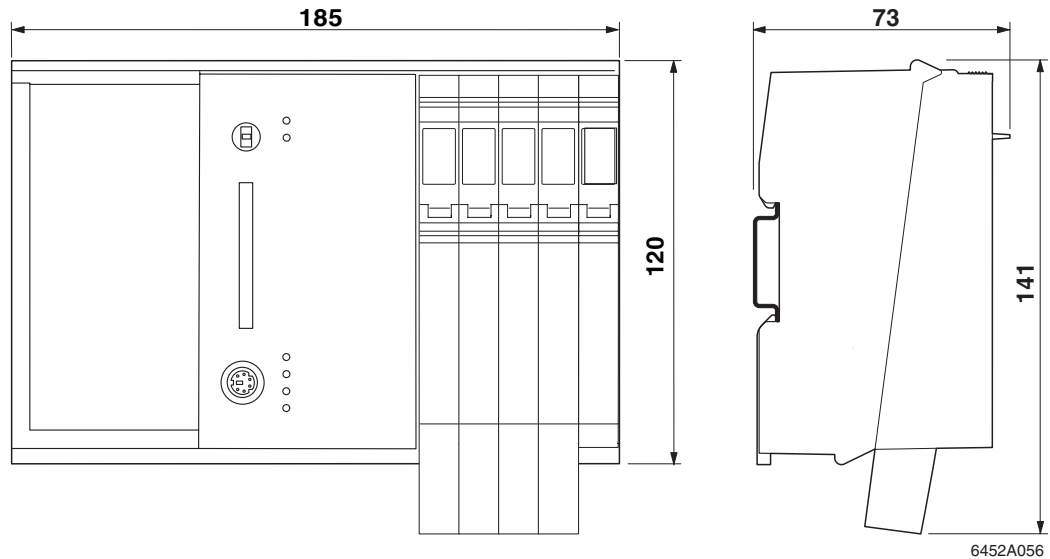

Figure 5-7 Dimensions of the electronics base (container housing 1, in mm)

IL SYS INST UM E

Container housing,
example:
ILC 3xx ...



6452A056

Figure 5-8 Dimensions of container housing 4 (in mm)

Container housing,
example:
ILC 200 IB

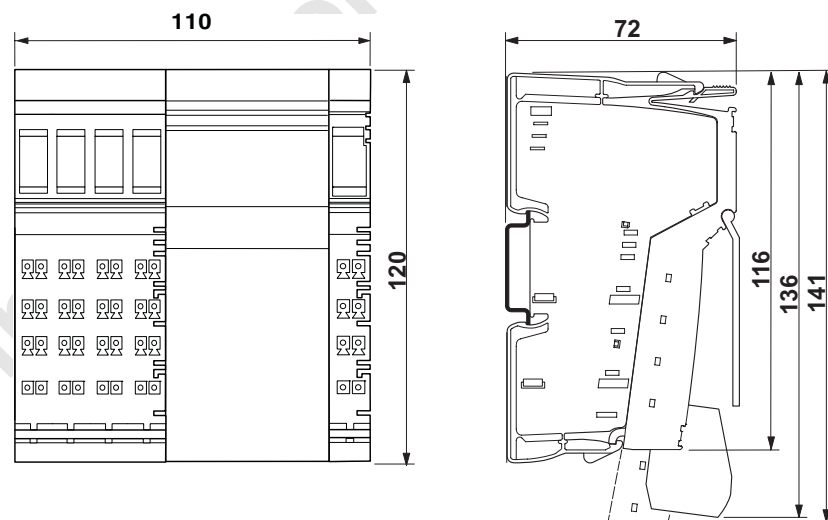

5520D127

Figure 5-9 Dimensions of container housing 3 (in mm)

Structure and dimensions

Dimensions of 2-slot,
4-slot, 8-slot housing

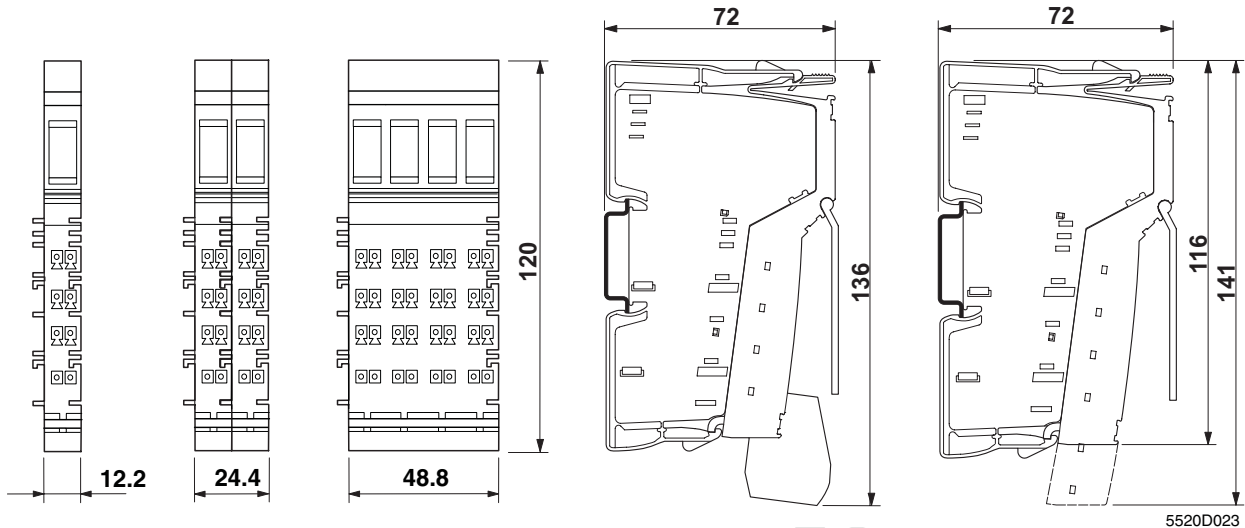

Figure 5-10 Dimensions of the electronics base with possible connectors (2-slot, 4-slot, 8-slot housing, in mm)

Examples for 2-slot, 4-slot or 8-slot housing:

2-slot housing

IB IL 24 DO 2-PAC

IB IL 24 DI 4-PAC

4-slot housing

IB IL AO 1/SF-PAC

IB IL CNT-PAC

8-slot housing

IB IL 24 DO 8-PAC

IB IL 24 DI 16-PAC

These bases take one, two or four 12.2 mm wide connectors.

Container housing,
example:
ASI MA IB IL
IB IL 24 SAFE 1-PAC
ILC 200 UNI

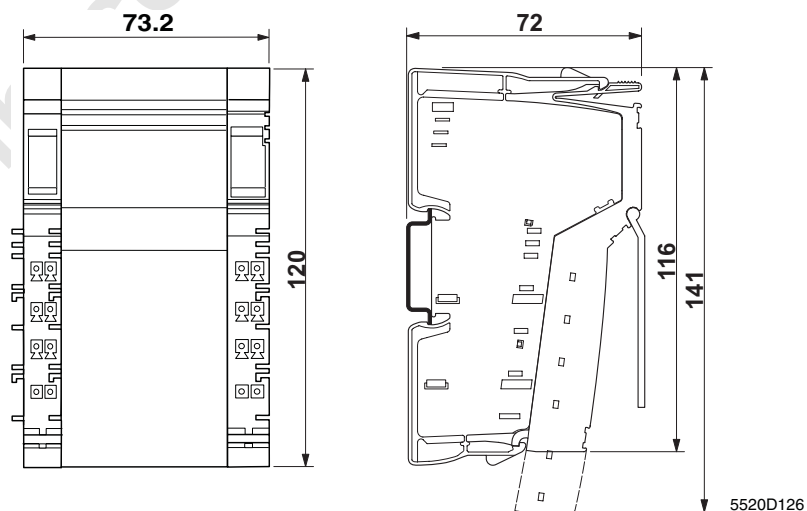

Figure 5-11 Dimensions of container housing 2 (in mm)

IL SYS INST UM E

Aluminum profile housing,
example:
IB IL DC AR 48/10A
IB IL EC AR 48/10-A-PAC

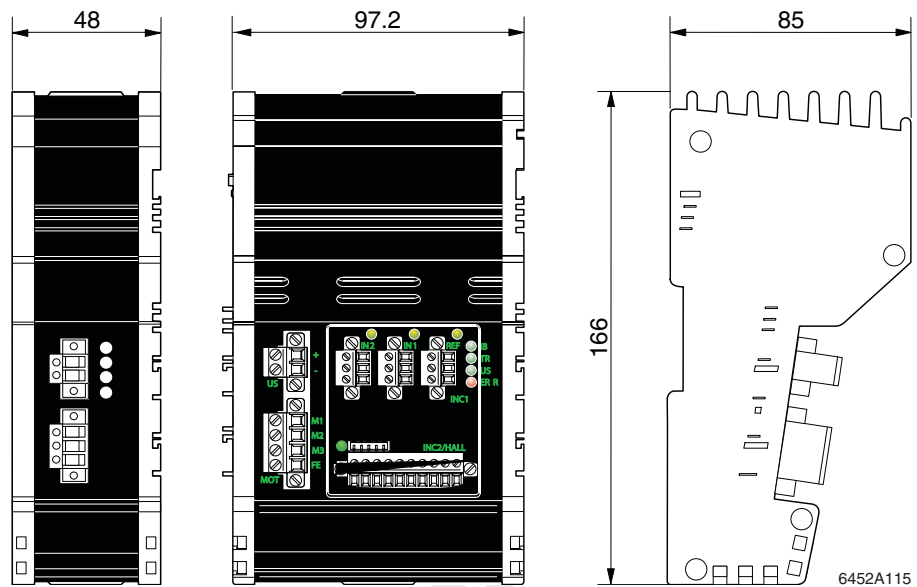

Figure 5-12 Dimensions of IB IL DC/EC AR ... (in mm)

Example:
IB IL 24 SDIO 4/4/1

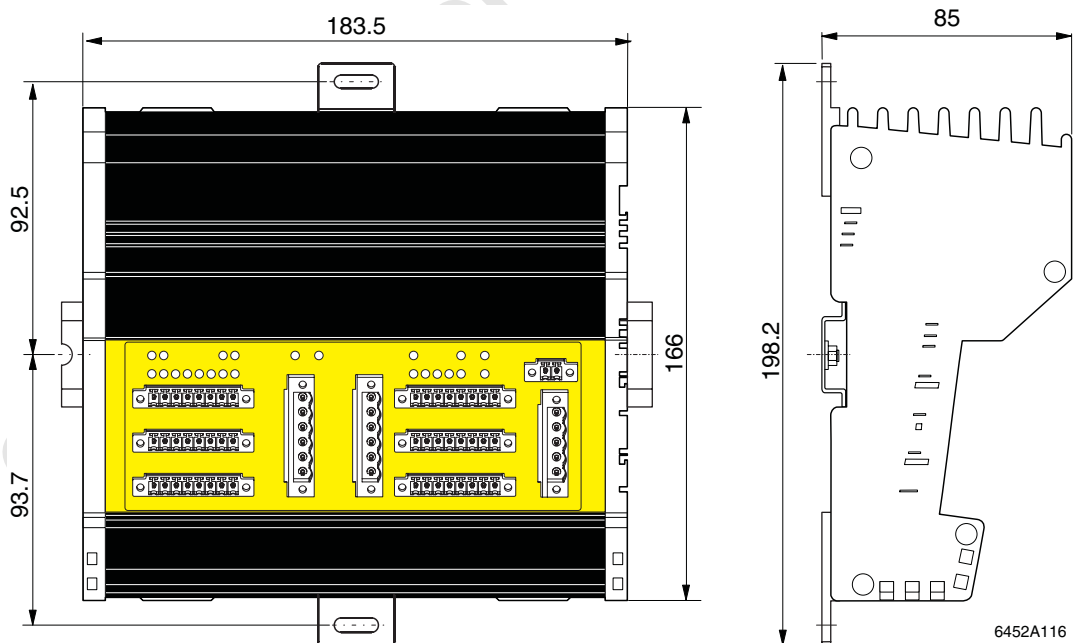

Figure 5-13 Dimensions of IB IL 24 SDIO ... (in mm)

5.1.8 Dimensions of power-level terminals

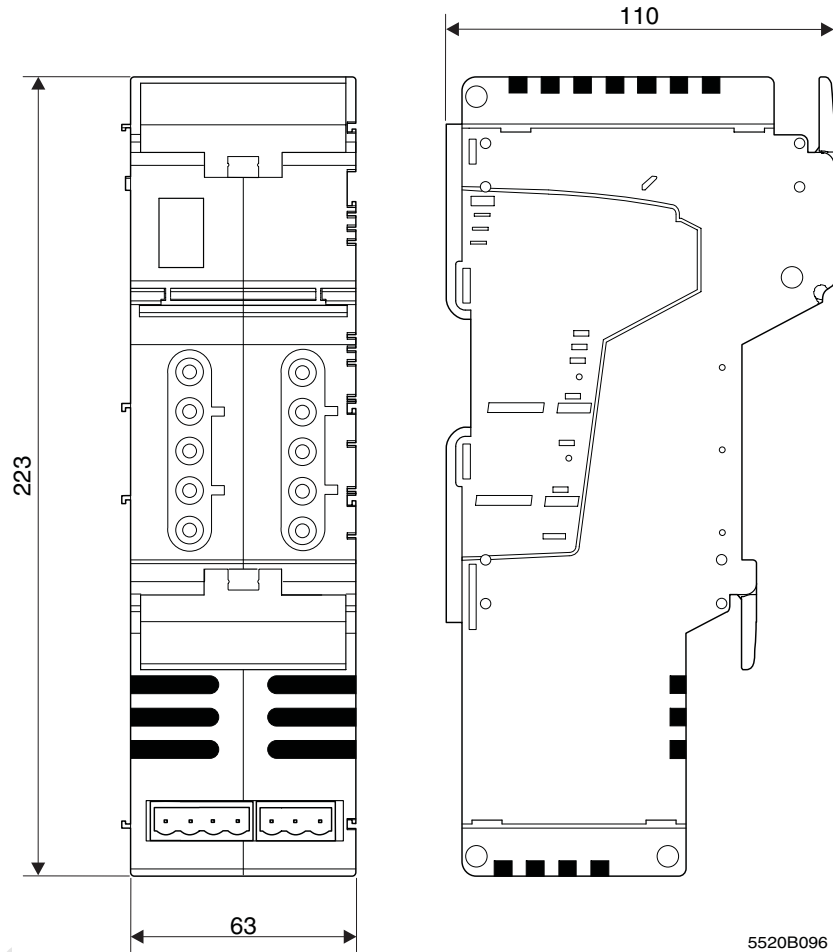

Figure 5-14 Dimensions of power housing



Please note the additional space required when inserting a connector for a hand-held operator panel.

5.2 Structure and dimensions of Inline Block IO modules

5.2.1 Basic structure of modules

Regardless of the function, an Inline Block IO module consists of the electronic module and the snap-on connectors (Inline connectors).

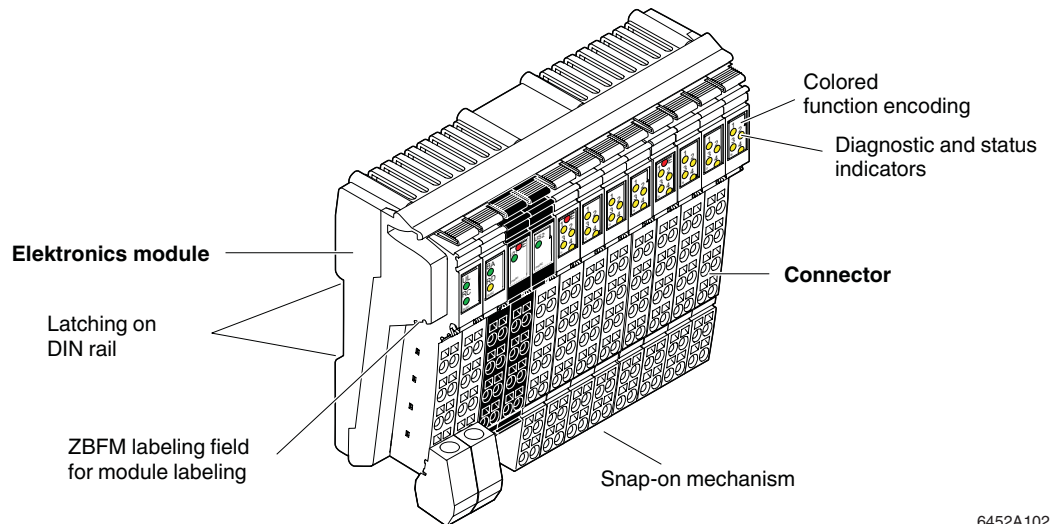

6452A102

Figure 5-15 Basic structure of an Inline Block IO module

ZBFM: Zack marker sheets, flat
(See also "Function identification and labeling" on page 5-5)



The components required for labeling are listed in the Phoenix Contact "CLIPLINE" catalog.

Electronic module

The electronic module holds the entire electronics for an Inline Block IO module.

Pressing the snap-on mechanism releases the latching, enabling the terminal to be removed by pulling it straight back from the DIN rail (see "Basic information about mounting" on page 9-2).

Connector

The I/O or supply voltages are connected using a pluggable connector. For more detailed information about the Inline connectors, please refer to Section 6, "Inline connectors".

5.2.2 Function identification and labeling

Housing

Apart from their width, Inline Block IO modules have the same appearance in terms of their housing type and housing color (green).

Function identification

The Inline Block IO modules are color-coded to enable visual identification of the function areas (1 in Figure 5-16).

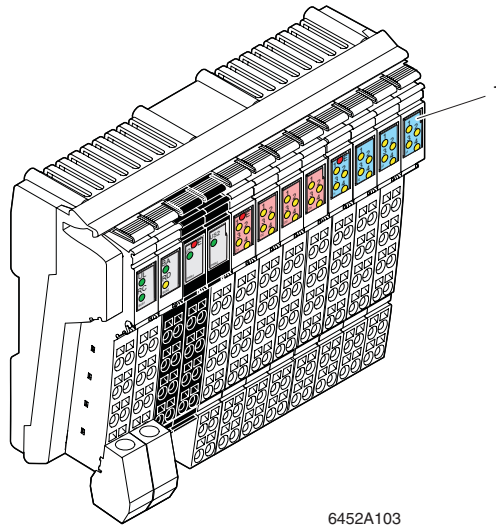

6452A103
Figure 5-16 Function identification

The following colors indicate the functions:

Table 5-3 Color-coding of module function areas

Color	Module function area
Gray	Bus/supply
Light blue	Digital input
Pink	Digital output
Purple	Digital input or output
Green	Analog input
Yellow	Analog output

5.2.3 Housing dimensions

Today, small I/O stations are frequently installed in 80 mm standard control boxes. Inline Block IO modules are designed so that they can be used in this type of control box. The terminal housing dimensions are determined by the dimensions of the electronic module and the dimensions of the connector.

The width of the electronic modules depends on the function and is either 95 mm or 156 mm.

When a connector is plugged in, each terminal has a depth of 55 mm.

The height of the terminal depends on the connector used and is a maximum of 141 mm.

For the dimensions of the modules, please refer to the relevant module-specific data sheet.

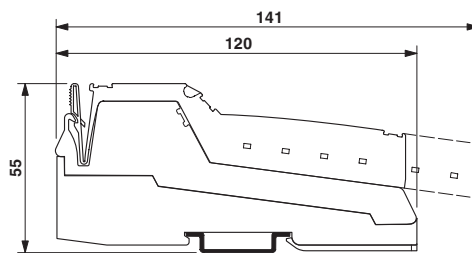

Figure 5-17 Maximum dimensions (dimensions in mm)

6 Inline connectors

Inline connectors are used on Inline Modular IO terminals and Inline Block IO modules.

6.1 Basic structure and dimensions of Inline connectors

Connector width

The connectors have a width of two terminal points.

Connector colors

To distinguish between the functions and voltage areas, the connectors have been assigned different colors:

Green	Connectors for low-level signal terminals (24 V DC, excluding power/segment terminals)
Black	Connectors for low-level signal power/segment terminals (24 V DC)
Gray	Connectors for terminals in the 120 V AC and 230 V AC areas (not required for Inline Block IO modules)

Basic structure

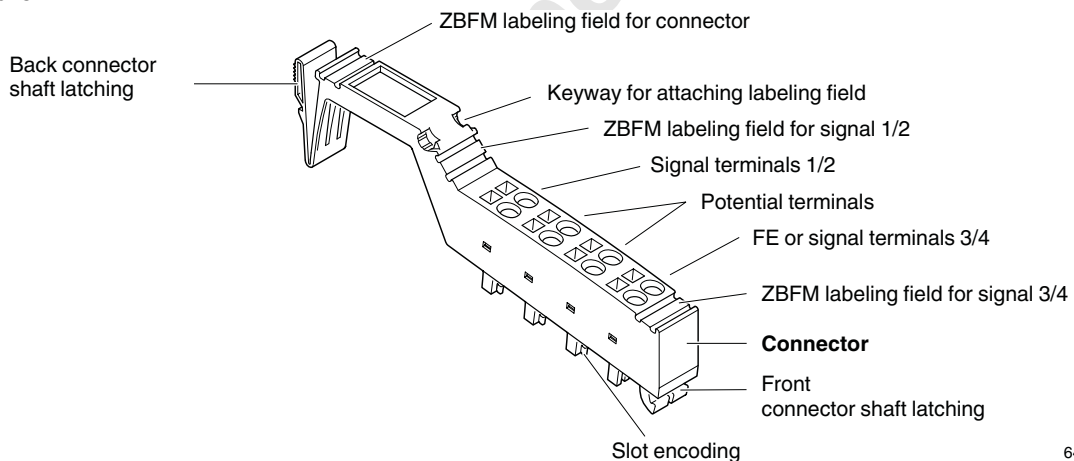

6452A101

Figure 6-1 Basic structure of an Inline connector

ZBFM: Zack marker sheets, flat
(See also "Function identification and labeling" on page 5-5)



The components required for labeling are listed in the Phoenix Contact "CLIPLINE" catalog.

IL SYS INST UM E

Dimensions

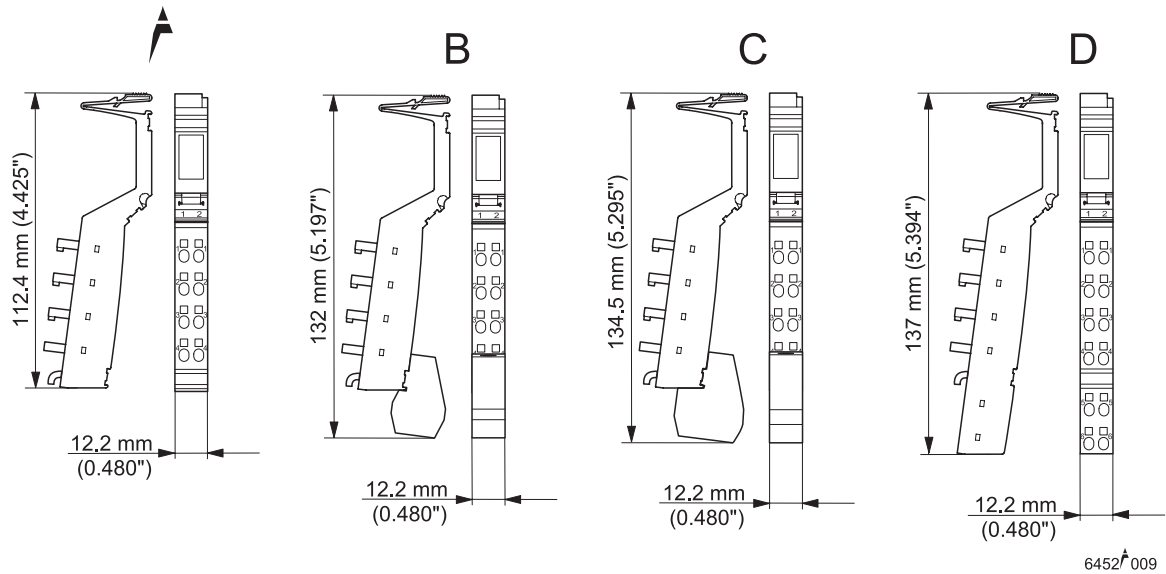

6452^h009

Figure 6-2 Connector dimensions

Key:

- A Standard connector
- B Shield connector for connecting one cable
- C Shield connector for connecting two cables
- D Extended double signal connector

The depth of the connector does not influence the overall depth of the Inline Modular IO terminal or Inline Block IO module.

6.2 Connectors for the 24 V DC area

Connector types

The following connector types are available for the 24 V DC area:

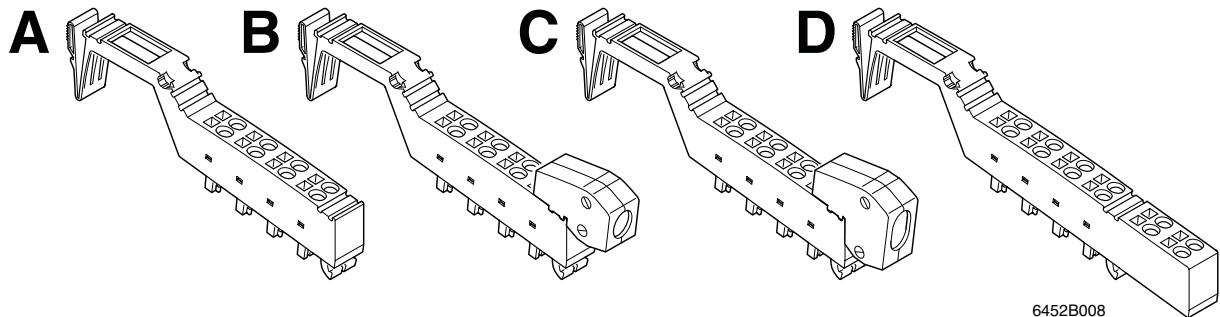

Figure 6-3 Connector types for Inline terminals

A Standard connector

The green standard connector is used for the connection of two signals in 4-wire technology or 8 signals in 1-wire technology (e.g., digital I/O signals).

The black standard connector is used to supply the supply voltage. Some of the adjacent contacts can be jumpered internally (see Figure 6-4 on page 6-4).

B Shield connector for connecting one cable

C Shield connector for connecting two cables

Green connectors B and C are used for signals connected using shielded cables (e.g., analog I/O signals, high-frequency counter inputs, remote bus cable).

FE or shielding is connected via a shield connection clamp rather than via a terminal point.

D Extended double signal connector

The green double signal connector is used for the connection of four signals in 3-wire technology (e.g., digital I/O signals).

The black double signal connector is used to supply the supply voltage. Some of the adjacent contacts can be jumpered internally (see Figure 6-4 on page 6-4).

IL SYS INST UM E

Connector identification

All connectors are available with and without color print. The connectors with color print (indicated with CP in the order designation) have terminal points that are color-coded according to their functions. The following colors indicate the signals of the terminal points:

Table 6-1 Color-coding of terminal points (24 V DC)

Color	Signal at terminal point
Red	+
Blue	-
Green	Functional earth ground (FE)
Green/yellow	Functional earth ground (FE); This marking may still be seen on older connectors. Functional earth ground is marked in green on modern connectors.

Internal jumpering



Depending on their function, the connectors may support internal jumpering.

NOTE: Disregarding this warning may result in malfunction

To avoid malfunction, only snap the connector onto an appropriate terminal. Refer to the relevant terminal-specific data sheet to select the correct connectors.

Only place **black** connectors on power or segment terminals.

When the terminal points are jumpered in the black connector, potential is routed through the jumpering in the connector and not through the printed circuit board of the terminal.

The complete current carrying capacity is ensured through this jumpering.

A **black** connector must **not** be placed on a terminal that is to be used for a double signal connector. Incorrect connection may lead to a short circuit between two signal terminal points.

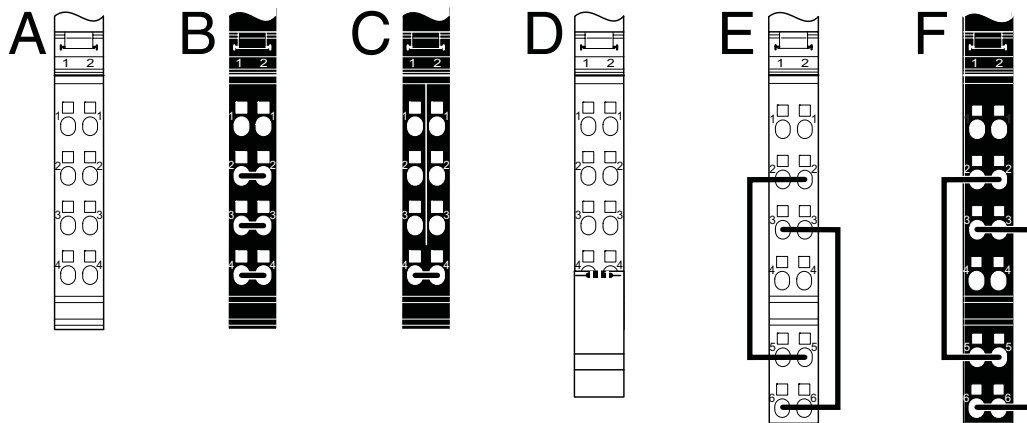

6452B028

Figure 6-4 Internal jumpering in connectors for the 24 V DC area

- A Green connector for connecting the I/O
- B Black connector for supplying the supply voltages **with** jumpering of the terminal points for power supply
- C Black connector for supplying the supply voltages **without** jumpering of the terminal points for power supply
- D Green shield connector for connecting shielded cables; the terminal points are jumpered via the shield connection.
- E Green double signal connector for connecting the I/O
- F Black connector for supplying the supply voltages **with** jumpering of the terminal points for power supply

The shield connector is jumpered between terminal points 1.4 and 2.4 through the shield connection as seen in Figure 6-4. All other connectors are jumpered **internally** through the terminal point connections **in the connector**.

6.3 Connectors for the 120 V AC/230 V AC area (Inline Modular IO)

Connector types

Gray standard connectors (see A in Figure 6-4) are available for the 120 V AC and 230 V AC areas. They have different color print according to their function.

Special features

The special features of the connectors and base for the 120 V AC and 230 V AC areas are described in "Electronics base and connectors for the different voltage areas" on page 3-5.

Table 6-2 Color-coding of terminal points (120 V AC/230 V AC)

Color	Signal at terminal point
Black	Phase (L)
Blue	Neutral conductor (N)
Green/yellow	Protective earth ground (PE)



The connectors for terminals used to isolate different voltage areas are color-coded with two colors. This includes connectors for power terminals and end terminals for the 120 V AC and 230 V AC areas, as well as distance terminals. The green marked side must point in the direction of the 24 V area and the gray marked side in the direction of the AC area.

IL SYS INST UM E

Internal jumpering and special features of the terminal points



Depending on their function, the connectors may support internal jumpering. In addition, some terminal points are not used or are indeed closed.

NOTE: Disregarding this warning may result in malfunction
To avoid malfunction, only snap the connector onto an appropriate terminal. Refer to the relevant terminal-specific data sheet to select the correct connectors.

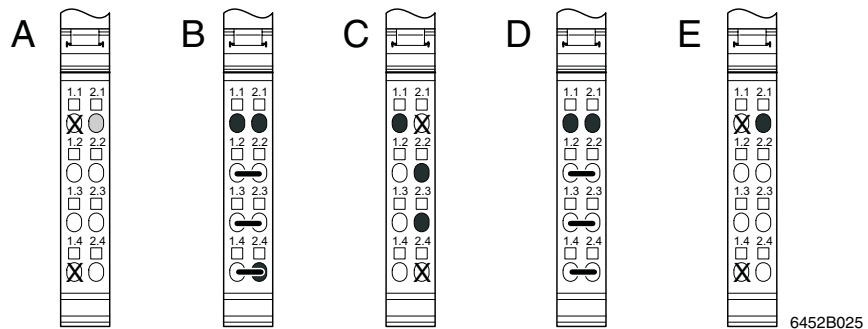

Figure 6-5 Internal jumpering and special features of connectors for the 120 V AC/230 V AC area

- X Connector contact not present
 - Terminal point without metal contact
 - Terminal point closed
- A Gray connector for plugging onto the left-hand side of a power terminal (start of the AC area)
 - B Gray connector for supplying the supply voltage
 - C Gray connector for connecting the I/O
 - D Gray connector for connecting the cables to a relay terminal
 - E Gray connector for plugging onto an end terminal

6.4 Numbering and labeling of terminal points

Labeling/terminal numbering

Terminal point numbering is explained using the example of an 8-slot Inline Modular IO terminal.

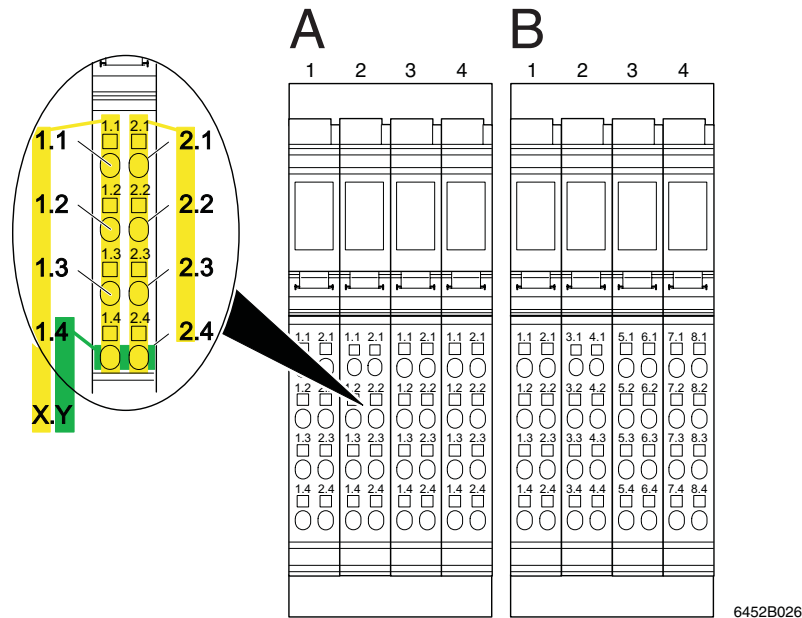

Figure 6-6 Terminal point numbering

Slot/connector

The slots (connectors) on a base are numbered consecutively. This numbering is **not** indicated on the terminal (shown above the terminals in Figure 6-6).

Terminal point

Connectors are available with different forms of marking. In general, the numbering format X.Y is marked above the terminal point.

1 Terminal point numbering **by connector** (detail A in Figure 6-6):

On these connectors:

X: Number of the terminal point column on the connector.

Y: Number of the terminal point within the terminal point column.

2 Terminal point numbering **by channel** (detail B in Figure 6-6):

For terminals with 8, 16 or 32 I/Os, connector sets are available in which the terminal point rows are numbered by terminal (1 to 8) rather than by connector (1 and 2).

X: Number of the terminal point column on the Inline terminal.

Y: Number of the terminal point within the terminal point column.



Select the necessary connectors from the Phoenix Contact "AUTOMATION" catalog.

IL SYS INST UM E

Additional labeling

In addition to this connector marking, you can identify the slots, terminal points, and connections using Zack marker strips and labeling fields.

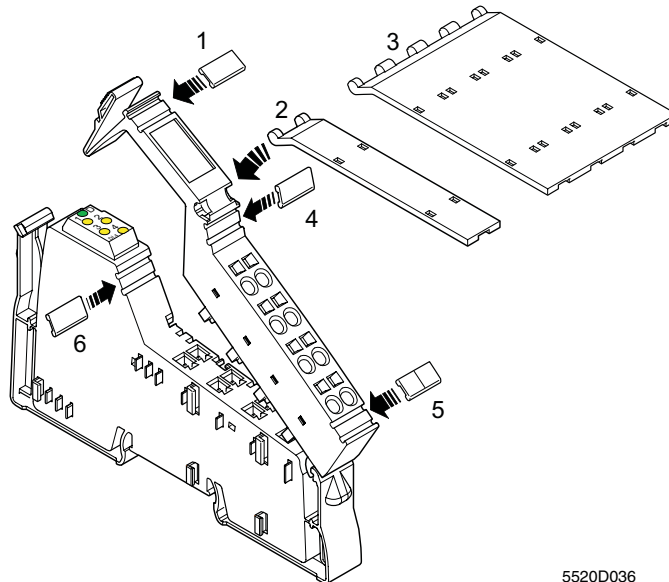

5520D036

Figure 6-7 Labeling

Various options are available for labeling the slots and terminal points:

- 1 Each connector can be labeled individually using Zack marker strips.
- 2/3 Another option is to use a labeling field. Labeling fields are available in two widths, either as a labeling field covering one connector (2; IB IL FIELD 2) or as a labeling field covering four connectors (3; IB IL FIELD 8). You can label each channel individually with free text. On the upper part of the connector there is a keyway for attaching this labeling field. The labeling field can be tilted up and down. In each end position a light latching ensures that the labeling field remains in place.
- 4/5 Each signal can be labeled individually using Zack marker strips. On a double signal connector, the upper keyway (4) is designed for labeling signals 1 and 2 and the lower keyway (5) is for signals 3 and 4.
- 6 On the electronics base, each slot can be labeled individually using Zack marker strips. These marker strips are covered when a connector is plugged in.

Using the marker strips on the connector and on the electronics base, you can clearly assign both connector and slot.

Insert strips for use with a laser printer are available for insertion in the IB IL FIELD 2 and IB IL FIELD 8 labeling fields (see "Ordering data for accessories" on page 11-7).



The components required for labeling are listed in the Phoenix Contact "CLIPLINE" catalog.

6.5 Terminal point keying

In order to prevent connectors being mixed up, the connection points between connectors and terminals can be keyed using the IL CP keying profile.

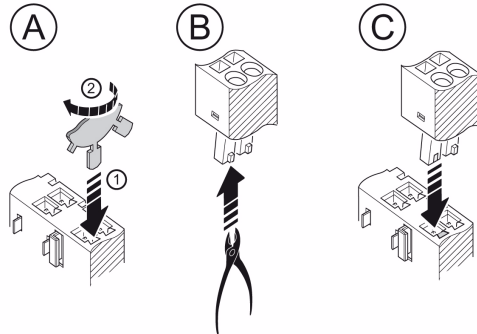

Figure 6-8 Connector and terminal keying

- A
 1. Insert a keying section of the keying profile in the corresponding keyway of the terminal point on the electronic housing.
 2. Twist the keying profile to break off the keying section.
- B Remove the keying tab from the corresponding slot keying on the connector.
- C Insert the keyed connector in the corresponding slot.

IL SYS INST UM E

onlinecomponents.com

7 Electrical potential and data routing (Inline Modular IO)



The AX SALES software provides support when configuring an Inline station (see "Software support" on page B-1).

7.1 Circuits and provision of supply voltages

There are several circuits within an Inline station. These are automatically created when the terminals are properly installed. The voltages of the different circuits are supplied to the connected terminals via potential jumpers.

An example of the circuits within an Inline station is given in "Example of a circuit diagram" on page 7-6. The descriptions in the following sections refer to this example.



Please refer to the terminal-specific data sheet for the circuit to which the I/O circuit of a specific terminal is to be connected.

Carrying capacity of the jumper contacts

Observe the maximum current carrying capacity of the jumper contacts on the side for each circuit. The current carrying capacities for all potential jumpers are given in the following sections and are summarized in "Current and voltage distribution" on page 7-12.

For the arrangement of the potential jumpers and information about current and voltage distribution on the potential jumpers, please refer to "Electrical potential and data routing" on page 7-8.

The connection of the supply voltages is described in "Connecting the power supplies" on page 10-6.



For voltage connection, please observe the notes in the terminal-specific data sheets.

7.1.1 Bus coupler supply



Please refer to the documentation for your bus coupler to determine the correct supply voltage for the bus coupler.

The voltages for the logic circuit U_L and the supply of the terminals for analog signals U_{ANA} are always internally generated from the bus coupler supply.

7.1.2 Logic circuit

The logic circuit with the communications power U_L starts at the bus coupler or at a power terminal (IB IL 24 PWR IN/R-PAC; IB IL 24 PWR IN/PS-PAC) and is led through all the terminals of an Inline station.

Function	The logic circuit (e.g., protocol chip, microcontroller) of the devices in a station is supplied with voltage from the logic circuit.
Voltage	The voltage in this circuit is 7.5 V DC $\pm 5\%$.
Provision of U_L	The communications power U_L is provided by the bus coupler or a corresponding power terminal from the connected supply voltage.
Current carrying capacity	<p>The maximum current carrying capacity is 2 A. If this value is reached, the voltage must be boosted via a power terminal or a new station must be created using a bus coupler.</p> <p>The current consumption from the logic circuit of each device is specified in the DB GB IB IL DEVICE LIST data sheet and the relevant terminal-specific data sheet.</p> <p>The communications power is not electrically isolated from the 24 V DC input voltage for the bus coupler.</p>



This maximum current carrying capacity can be limited by certain bus couplers or corresponding power terminals. Please refer to the information in the terminal-specific data sheets.

7.1.3 Analog circuit

The analog circuit with the supply for the analog terminals (also referred to as analog voltage) U_{ANA} starts at the bus coupler or at a power terminal (IB IL 24 PWR IN/R-PAC; IB IL 24 PWR IN/PS-PAC) and is led through all the terminals of an Inline station.

Function	The I/O for analog signal terminals is supplied from the analog circuit.
Voltage	The voltage in this circuit is 24 V DC (+20%, -15%).
Provision of U_{ANA}	The analog voltage U_{ANA} is provided by the bus coupler or a corresponding power terminal from the connected supply voltage.
Current carrying capacity	<p>The maximum current carrying capacity is 0.5 A. If this value is reached, the voltage must be boosted via a power terminal or a new station must be created using a bus coupler.</p> <p>The current consumption from the analog circuit of each device that is supplied from U_{ANA} is specified in the DB GB IB IL DEVICE LIST data sheet and the relevant terminal-specific data sheet.</p>

Electrical potential and data routing (Inline Modular IO)

7.1.4 Main circuit

The main circuit with the main voltage U_M starts at the bus coupler or a power terminal and is led through subsequent terminals until it reaches the next power terminal.



Please note the special requirements of Inline terminals with relay outputs. These terminals interrupt the potential jumpers U_M and U_S .

A new circuit starts at the next power terminal. This circuit is electrically isolated from the previous one if electrically isolated power supply units are used.

Several power terminals can be used within one station.

Function

The segment voltage U_S can be tapped from the main voltage U_M using different segment terminals. Several independent segments can thus be created within the main circuit. The main circuit provides the supply voltage for these segments.

Some terminals access the main circuit directly. For example, the encoder supply for positioning terminals is tapped from the main circuit, while the I/O is supplied from the segment circuit.

Voltage

The voltage in this circuit must not exceed 30 V DC.

Current carrying capacity

The **maximum** current carrying capacity for the main circuit is **8 A** (total current with the segment circuit).



This maximum current carrying capacity can be limited by certain terminals. Please refer to the information in the terminal-specific data sheets.

If the limit value of the potential jumpers U_M and U_S is reached (total current of U_S and U_M), a new power terminal must be used.

Provision of U_M

In the simplest case, the main voltage U_M can be supplied at the bus coupler.

The main voltage U_M can also be supplied via a power terminal. A power terminal **must** be used if:

- 1 A bus coupler that cannot supply the main voltage is used.
- 2 Different voltage areas (e.g., 24 V DC and 120 V AC) are to be created.
- 3 Electrical isolation between different I/O areas is to be created.
- 4 The maximum current carrying capacity of the potential jumpers U_M , U_S , and GND (total current of U_S and U_M) is reached.

7.1.5 Segment circuit

The segment circuit with segment voltage U_S starts at the bus coupler or a power or segment terminal and is led through the subsequent terminals until it reaches the next power or segment terminal.



Please note the special requirements of Inline terminals with relay output. These terminals interrupt the potential jumpers U_M and U_S .

You can use several segment terminals within a main circuit and therefore segment the main circuit.

Function

Almost all the terminals in the Inline station except the analog terminals are supplied from the segment circuit (e.g., digital input terminals, digital output terminals).

The segment circuit also provides the auxiliary voltage for controlling circuit breakers and contactors.

Some terminals access both the segment circuit and the main circuit. For example, the encoder supply for positioning terminals is tapped from the main circuit, while the I/O is supplied from the segment circuit.

The segment circuit can be switched off or fused using the safety or segment terminals. It has the same reference ground as the main circuit. This means that circuits with different fuses can be created within the station without external cross-wiring.

Voltage

The voltage in this circuit must not exceed 30 V DC.

Current carrying capacity

The **maximum** current carrying capacity for the segment circuit is **8 A** (total current with the main circuit).



This maximum current carrying capacity can be limited by certain terminals. Please refer to the information in the terminal-specific data sheets.

If the limit value of the potential jumpers U_M and U_S is reached (total current of U_S and U_M), a new power terminal must be used.

Provision of U_S

There are various ways of providing the segment voltage U_S :

- 1 The segment voltage can be supplied at the bus coupler or a power terminal.
- 2 The segment voltage can be tapped from the main voltage at the bus coupler or a power terminal using a jumper or a switch.
- 3 An IB IL 24 PWR IN/2-F...-PAC power terminal with fuse for the main and segment circuit or a segment terminal with fuse for the segment circuit can be used. In these terminals the segment voltage is automatically tapped from the main voltage.
- 4 A segment terminal can be used without a fuse and the segment voltage can be tapped from the main voltage using a jumper or a switch.



The creation of segments is not possible for the 120 V AC and 230 V AC voltage levels. Here, only one circuit is used, which corresponds to the main circuit.

Electrical potential and data routing (Inline Modular IO)

7.1.6 Mains voltage for power-level terminals

The mains voltage for power-level terminals is not provided via the potential jumpers. It is either supplied to the power-level terminal via a power connector or led between directly adjacent power-level terminals via power bridges.

Voltage

The mains voltage must have the following values:

	IB IL 400 ELR ...	IB IL 400 MLR ...
Nominal voltage during operation (conductor voltage)	400 V AC	400 V AC
Voltage range	187 V AC ... 440 V AC + 0% with safe isolation between mains and SELV	187 V AC ... 519 V AC + 0% with safe isolation between mains and SELV; 187 V AC ... 600 V AC + 0% with basic insulation between mains and SELV

Frequency

The frequency of the mains voltage must be 50 Hz or 60 Hz.

Current carrying capacity

The maximum current carrying capacity for the incoming mains must be 20 A. If this value is reached, it must be reinjected.

7.1.7 Example of a circuit diagram

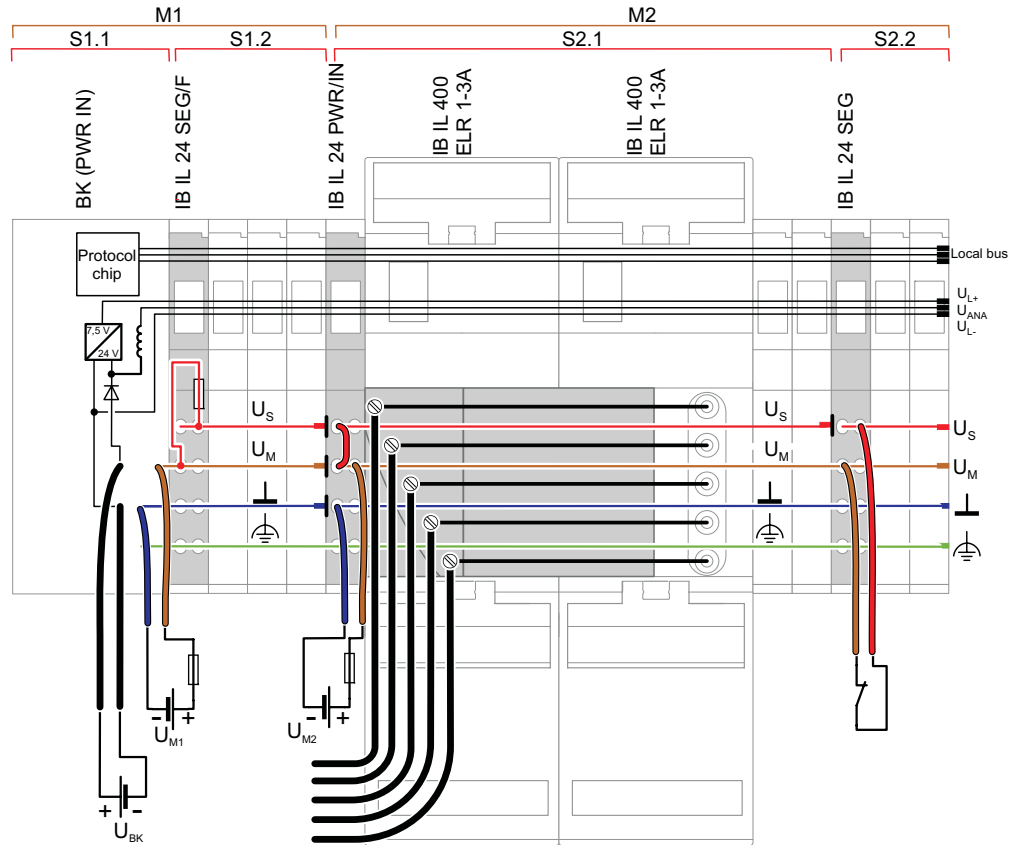

6452C002

Figure 7-1 Potential routing within an Inline station

The illustrated Inline station is a typical example. It shows the supply and provision of different voltages and their forwarding via potential jumpers. Explanations for this can be found in the following sections.

Mx	Main circuit (e.g., M1, M2)
Sx,y	Segment circuit y in main circuit x (e.g., S2.1, S2.2)
BK (PWR IN)	Bus coupler in conjunction with a power terminal, if required
U_{BK}	Bus coupler supply (supply for bus coupler, generates U _{ANA} and U _L)
U_M	Main supply (I/O supply in the main circuit)
U_S	Segment supply (I/O supply in the segment circuit)
U_{ANA}	I/O supply for analog terminals
U_L	Communications power
Local bus	Data jumper for the local bus
⊥	Ground (GND for the supply voltages U _M and U _S)

Electrical potential and data routing (Inline Modular IO)



Noiseless ground (functional earth ground, FE)



Protective earth ground



Indicates the interruption of a potential jumper

Main circuit M1/ segment S1.1

The supply voltage for the bus coupler U_{BK} is supplied at the bus coupler (BK). In addition, the main voltage U_{M1} is supplied at the bus coupler or a subsequent power terminal.

The communications power U_L and the supply voltage for the analog terminals U_{ANA} are generated from the bus coupler supply and led through the entire station.

Electrical isolation between logic and I/O is created through the separate supply of the bus coupler supply U_{BK} and the main voltage U_{M1} .



If these voltages are not supplied separately (e.g., only the voltage U_{M1} , from which U_L and U_{ANA} are also generated), there is no electrical isolation between logic and I/O.

No terminals are used in segment S1.1.

Segment S1.2

In a segment terminal with fuse, the segment voltage U_S for segment S1.2 is automatically tapped from the main voltage U_{M1} . This segment circuit is protected by the internal fuse.



This segment terminal has been specifically used to create a protected segment circuit without the need for an additional external fuse. If this is not necessary, the terminal does not have to be used. In this case, the connection between U_M and U_S on the bus coupler must be established using a jumper (as shown on the IB IL 24 PWR/IN-PAC terminal) or a switch (as shown on the IB IL 24 SEG-PAC terminal).

Main circuit M2/ segment S2.1

The supply voltage for the power-level terminals and the subsequent terminals should be supplied separately. For this, a new power terminal (e.g., IB IL 24 PWR/IN-PAC) is used, which supplies the supply voltage U_{M2} .

Using a jumper, the segment voltage U_S for segment S2.1 is tapped from the main voltage U_{M2} at this terminal.

Segment S2.2

The segment voltage U_S is provided at the IB IL 24 SEG-PAC segment terminal via a switch. Output terminals installed here can therefore be switched externally.

Examples of errors and their effects:

- 1 In this example structure, a short circuit in segment S1.2 would not affect the terminals in other segments. The fuse in the IB IL 24 SEG/F-PAC segment terminal means that only segment S1.2 is switched off.
- 2 If an error occurred in the system, the terminals in segment S2.2, for example, could be switched on or off without affecting the terminals in other segments.

7.2 Electrical potential and data routing

7.2.1 Arrangement of potential and data jumpers

An important feature of Inline is its internal potential routing system. The electric connection between the individual station devices is created automatically when the station is installed. When the individual station devices are connected, a power rail is created for the relevant circuit. Mechanically, this is created by interlocking knife and featherkey contacts from the adjacent terminals.

This potential routing eliminates the need for additional external potential routing or cross-wiring.



The 400 V AC mains voltage for power-level terminals is not led via the internal station potential routing. It is supplied via a power connector and is led between two power-level terminals via power bridges.

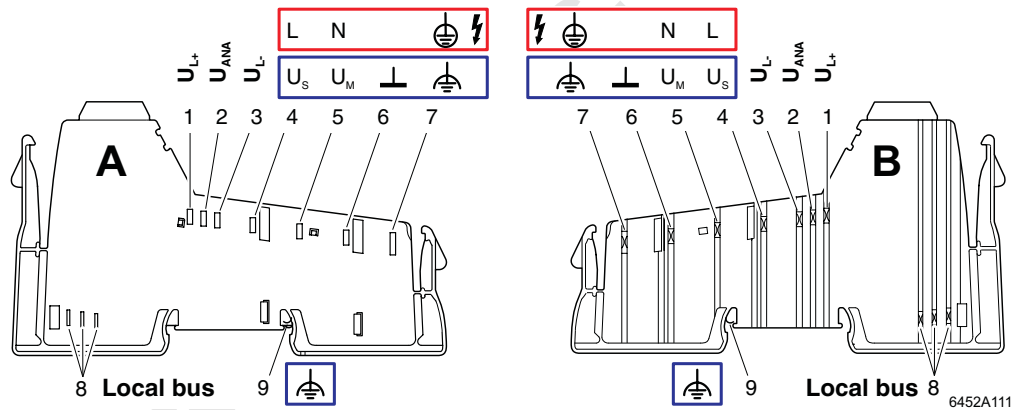

Figure 7-2 Basic arrangement of potential and data jumpers



Potential jumper for the 24 V AC voltage area



Potential jumper for the 120 V AC and 230 V AC voltage areas

Electrical potential and data routing (Inline Modular IO)

Table 7-1 Potential and data jumpers (24 V DC area)

No.	Function		Meaning
See Figure 7-2 "Basic arrangement of potential and data jumpers" on page 7-8			
Potential jumpers			
1	7.5 V DC	U _{L+}	Communications power for the bus interface
2	24 V DC	U _{ANA}	I/O supply for analog terminals
3	GNDL	U _{L-}	Ground of communications power and I/O supply for analog terminals
4	24 V DC	U _S	Segment circuit supply (if necessary with overload protection)
5	24 V DC	U _M	Main circuit supply (if necessary with overload protection)
6	GND	GND	Ground of segment and main supply
7	FE	FE	Functional earth ground
(9)	FE spring		FE contact to the DIN rail (for bus couplers, segment terminals, and power terminals for the SELV area)
Data jumper			
8			Local bus



Terminal inputs and outputs are supplied with voltage via the segment circuit. The voltage for the segment circuit can be tapped from the main circuit. In addition, some terminals tap the voltage directly from the main circuit. For more detailed information about the circuits that are created via the potential jumpers U_L, U_{ANA}, U_M, and U_S, please refer to page 7-1.



Depending on the terminal function, not all of the jumpers listed in Figure 7-2 are present on a terminal. Please refer to the circuit diagram of the terminal to see which jumpers are available for a terminal and how they are internally connected. The circuit diagram is shown in the terminal-specific data sheet.

IL SYS INST UM E

GND
(24 V DC area)

This potential jumper is ground for the main and segment circuits.



NOTE: Overload

Please note that the GND potential jumper carries the total current of the main and segment circuits. The total current of the main and segment circuits must not exceed the maximum current carrying capacity of the potential jumpers (8 A). The maximum current carrying capacity is determined not only by the potential jumpers, but also by the power/segment terminal used.

Calculate the current in the station. Refer to the data provided in the terminal-specific data sheets for your particular application.



The AX SALES software provides support when calculating the currents (see "Software support" on page B-1).

FE
(24 V DC area)

The FE potential jumper is connected to the grounded DIN rail via the FE spring at each bus coupler, each 24 V power terminal, and each segment terminal and is led through all subsequent 24 V terminals.

In addition, connect the FE connection to a grounding terminal at the bus coupler.

If the FE jumper is interrupted by a 120 V AC/230 V AC voltage level, reconnect the FE connection to a grounding terminal at the subsequent 24 V DC power terminal.



Please also observe the information in "Grounding concept" on page 9-8.

FE spring
(24 V DC area)

This spring creates the FE contact between the bus coupler, a 24 V DC power terminal or a segment terminal, and the grounded DIN rail.

Data routing
(all areas)

The bus signal is also transmitted within the station using a connection that is created automatically when the station devices are snapped on.

Current carrying capacity
(all areas)

The maximum total current flowing through the potential jumpers is limited. The maximum current carrying capacity for each circuit is specified in "Circuits and provision of supply voltages" on page 7-1.



Please also observe the information about the current carrying capacity of the power and segment terminals provided in the terminal-specific data sheets.



NOTE: Malfunctions

If the current carrying capacity of the potential jumpers U_L or U_{ANA} is reached, the voltage must be boosted via a power terminal, or a new station must be created using a bus coupler

If the current carrying capacity of the potential jumpers U_M , U_S , and GND is reached (total current of U_S and U_M), a new power terminal must be used.



The AX SALES software provides support when calculating the currents (see "Software support" on page B-1).

Electrical potential and data routing (Inline Modular IO)

Table 7-2 Potential and data jumpers (120 V AC/230 V AC area)

No.	Function		Meaning
See Figure 7-2 "Basic arrangement of potential and data jumpers" on page 7-8			
Potential jumpers			
1	7.5 V DC	U _{L+}	Communications power for the bus interface
2	24 V DC	U _{ANA}	I/O supply for analog terminals
3	GNDL	U _{L-}	Ground of communications power and I/O supply for analog terminals
4	120 V AC/ 230 V AC	L1	Phase L1
5	0 V	N	PEN conductor
6	-		Not present
7	PE	PE	Protective earth ground
(9)	-		Not present
Data jumper			
8			Local bus



Depending on the terminal function, not all of the jumpers listed in Figure 7-2 are present on a terminal. Please refer to the circuit diagram of the terminal to see which jumpers are available for a terminal and how they are internally connected. The circuit diagram is shown in the terminal-specific data sheet.

PE
(120 V AC/230 V AC area)

The PE potential jumper is used in the 120 V AC/230 V AC area. It must be connected to protective earth ground via the corresponding connection at the power terminal for these voltage areas.

7.2.2 Current and voltage distribution

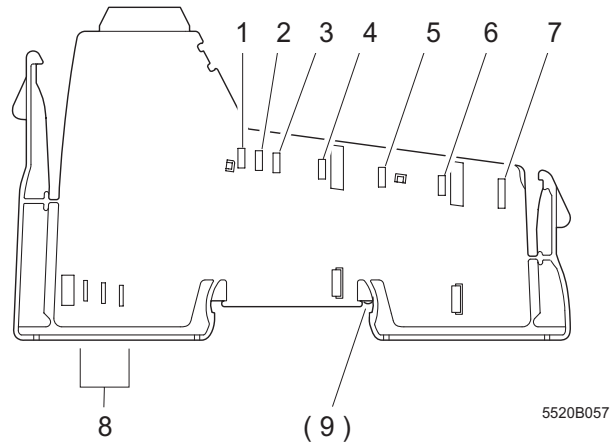

Figure 7-3 Current and voltage distribution

Table 7-3 Current and voltage distribution in potential and data jumpers (24 V DC)

No.	Function	Voltage to contact ¹		Current	
		Minimum	Maximum	Maximum	
Potential jumpers					
1	7.5 V DC	U_{L+}	7.0 V DC	7.87 V DC	2 A
2	24 V DC	U_{ANA}	19.2 V DC	30 V DC	0.5 A
3	GNDL	U_{L-}	0 V DC	0 V DC	2.5 A
4	24 V DC	U_S	19.2 V DC	30 V DC	8 A
5	24 V DC	U_M	19.2 V DC	30 V DC	
6	GND	GND	0 V	0 V	8 A
7	FE	FE	Not defined	Not defined	Not defined
(9)	FE spring				
Data jumpers					
8 a	Bus signal				
8 b	Bus signal				
8 c	Clock				

¹ Contact no. 3 is reference potential for the logic.
Contact no. 6 is reference potential for the I/O.
If there is no electrical isolation between logic and I/O, both have the same potential.

Electrical potential and data routing (Inline Modular IO)

Table 7-4 Current and voltage distribution in potential and data jumpers
(120 V AC/230 V AC)

No.	Function		Voltage to contact ¹		Current
			Minimum	Maximum	Maximum
Potential jumpers					
1	7.5 V DC	U _{L+}	7.0 V DC	7.87 V DC	2 A
2	24 V DC	U _{ANA}	19.2 V DC	30 V DC	0.5 A
3	GNDL	U _{L-}	0 V DC	0 V DC	2.5 A
4	120 V AC/230 V AC	L1	12 V AC	253 V AC	8 A
5	PEN conductor	N	0 V	0 V	8 A
6	-				
7	PE	PE	Not defined	Not defined	Not defined
(9)	-				
Data jumpers					
8 a	Bus signal				
8 b	Bus signal				
8 c	Clock				

¹ Contact no. 3 is reference potential for the logic.
Contact no. 5 is reference potential for the I/O.

IL SYS INST UM E

onlinecomponents.com

8 Diagnostic and status indicators

All Inline Block IO modules and Inline Modular IO terminals (referred to below as the device) are equipped with diagnostic and status indicators for quick local error diagnostics. They enable the clear localization of system errors (bus errors) or peripheral faults.

Diagnosics

The diagnostic indicators (red, yellow or green) provide information about the state of the device and, in the event of an error, provide information about the type and location of the error. The device is operating correctly if all of its green LEDs are on.

Status

The status indicators (yellow) indicate the status of the relevant input/output and the connected I/O device.

Extended diagnostics

Some devices have extended diagnostics. A short circuit or overload of the sensor supply is indicated for each input. If a short circuit occurs at an output, each channel is diagnosed individually. Information about the supply voltage is also reported. Information about peripheral faults is sent to the control system with precise details of the error type and is displayed using status indicators.



For information about the diagnostic and status indicators on a specific device, please refer to the device-specific data sheet.

8.1 Indicators on Inline Modular IO terminals

8.1.1 Indicators on bus couplers and terminals with remote bus branch



For the meaning of the diagnostic and status indicators of the bus coupler and the terminals with remote bus branch, please refer to the corresponding documentation.

8.1.2 Indicators available on different terminals in the Inline system

Some indicators can be found on various terminals (see section below) and generally have the same meaning:

UM	Green LED	Supply in the main circuit
	ON:	Supply present in the main circuit
	OFF:	Supply not present in the main circuit
US	Green LED	Supply in the segment circuit
	ON:	Supply present in the segment circuit
	OFF:	Supply not present in the segment circuit
D	Green LED	Diagnostics
	ON:	Data transmission active within the station
	Flashing:	
	0.5 Hz: (slow)	Communications power present, data transmission not active within the station
	2 Hz: (medium)	Communications power present, peripheral fault (e.g., fuse has blown, voltage not present)
	4 Hz: (fast)	Communications power present, error at the interface between previous and flashing terminal (the terminals after the flashing terminal cannot be addressed). (E.g., loose contact at the bus interface, terminal before the flashing terminal has failed, another terminal was snapped on during operation (not permitted))
	OFF:	Communications power not present

8.1.3 Indicators on power and segment terminals

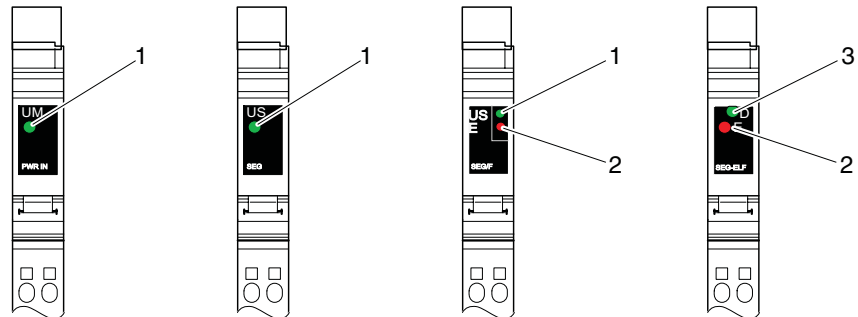

6452C029

Figure 8-1 Possible indicators on power and segment terminals

Diagnostics

The following states can be read on power and segment terminals:

Power terminal		
UM (1)	Green LED	Supply voltage in the main circuit (for meaning see page 8-2)
Segment terminal		
US (1)	Green LED	Supply voltage in the segment circuit (for meaning see page 8-2)
Power terminal with fuse and diagnostics/ segment terminal with electronic fuse		
D (3)	Green LED	Diagnostics (for meaning see page 8-2)
Also on terminals with fuse		
E (2)	Red LED	Fuse status
	ON:	Fuse not present or blown
	OFF:	Fuse OK



On terminals with fuses, the green UM or US LED indicates that the main or segment voltage is present **on the line side** of the fuse, meaning that if the green LED is on, there is voltage **on the line side** of the fuse. If the red E LED is also on, the fuse has blown or is missing and no voltage is applied **after** the fuse.



If the red E LED is on and the green D LED is flashing at 2 Hz on terminals with fuse and diagnostics, there is no voltage present after the fuse. Thus, a blown fuse is indicated by both diagnostic indicators (E and D).

8.1.4 Indicators on I/O terminals



In this section, I/O terminals are all terminals that acquire or output signals, i.e., all terminals excluding bus couplers, power, segment, and power-level terminals.



The LEDs of the I/O terminals are electrically located in the logic area. This may mean that the LED of an output is on but the output cannot be controlled due to an error between the logic area and the digital output. The LED does not monitor the output state. In the event of an error, the actual output state may differ from the state indicated by the LED.



Figure 8-2 Indicators on I/O terminals

Diagnostics

The following states can be read on I/O terminals:

D (1)	Green LED	Diagnostics (for meaning see page 8-2)
------------------------	-----------	--

Status

The status of the input or output can be read from the relevant yellow LED:.

1, 2, 3, 4 (2)	Yellow LED	Status of the input/output
	ON:	Corresponding input/output set
	OFF:	Corresponding input/output not set

For terminals with extended diagnostics

E1, E2, E3, E4	Yellow LED	The meaning depends on the terminal. It is described in the terminal-specific data sheet, e.g.: Short circuit/overload of the initiator supply Short circuit of an output Diagnostic input error message
	ON:	An error has occurred
	OFF:	No error



Additional diagnostic or status indicators can be found on the terminals. They are described in the corresponding documentation.

Assignment between status LED and input/output

The figure shows the general principle of the assignment of a status LED to its input or output.

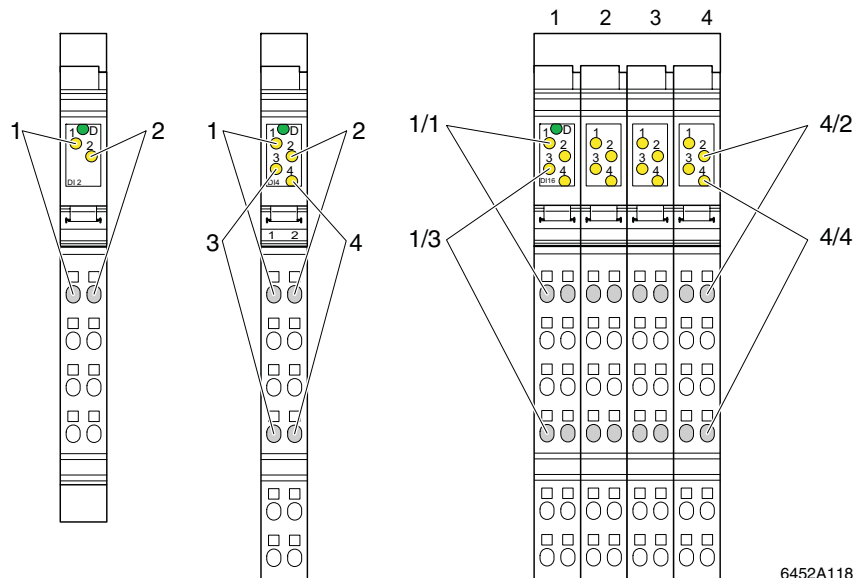

Figure 8-3 Assignment between status LED and input/output

Please refer to "Function identification and labeling" on page 5-5 for an explanation of the numbering.

With an 8-slot terminal, the LEDs of a slot belong to the terminal points of this slot. Every slot can be considered a 2-slot terminal.

For a 2-slot terminal with four inputs or outputs (middle example in Figure 8-3), the following LEDs belong to the following terminal points:

LED 1	Terminal point 1.1
LED 2	Terminal point 2.1
LED 3	Terminal point 1.4
LED 4	Terminal point 2.4

On the 8-slot terminal in Figure 8-3 and Figure 8-4, e.g., with 4/2, LED 2 on slot 4 is indicated. The LED belongs to input 14 at terminal point 4.2.1 (slot 4, terminal point 2.1).

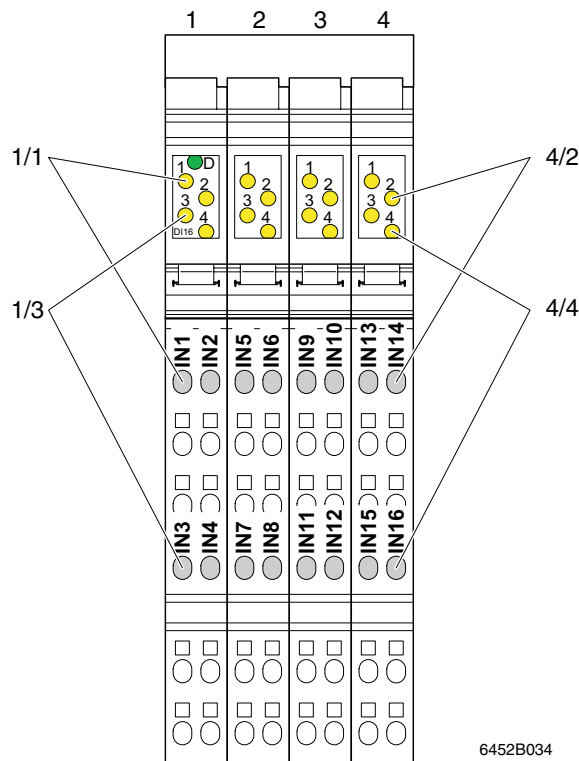

Figure 8-4 Assignment between status LED and input/output using the example of an IB IL 24 DI 16-PAC terminal



For every terminal, the assignment is specified in the terminal-specific data sheet.

8.1.5 Indicators on power-level terminals

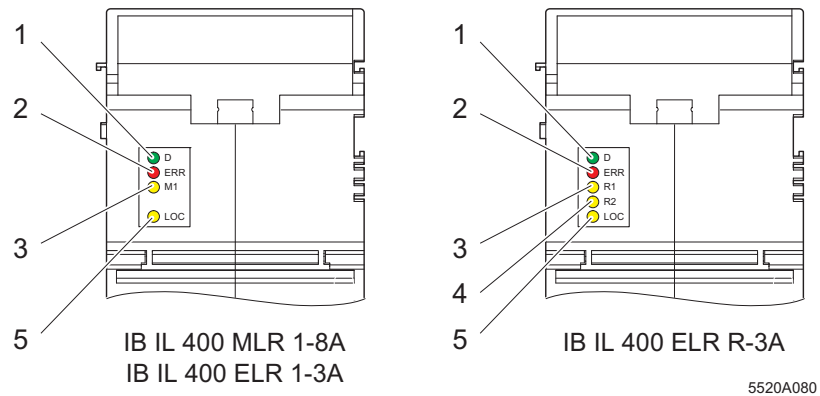

Figure 8-5 Indicators on power-level terminals

5520A080

Diagnostics

The following states can be read on power-level terminals:

D (1)	Green LED	Diagnostics (for meaning see page 8-2)
ERR	Red LED	Group error message/motor protection
(2)	ON:	Operating error (motor protection has been triggered, contactor cannot be controlled)
	OFF:	No error

Status

The status of the motor and manual mode can be read from the corresponding yellow LED:

M1 (3)	Yellow LED	Motor
	ON:	Motor switched on
	OFF:	Motor not switched on
R1 (3)	Yellow LED	Motor in direction of rotation 1
	ON:	Motor in direction of rotation 1 switched on
	OFF:	Motor in direction of rotation 1 not switched on
R2 (4)	Yellow LED	Motor in direction of rotation 2
	ON:	Motor in direction of rotation 2 switched on
	OFF:	Motor in direction of rotation 2 not switched on
LOC (5)	Yellow LED	Manual mode (local)
	ON:	Manual mode active
	OFF:	Bus mode active

8.2 Indicators on Inline Block IO modules

An Inline Block IO module can be divided into the function areas bus system, supply, and I/O. Local diagnostic and/or status indicators are assigned to each function area.

8.2.1 Indicators in the bus system function area (BUS)



For the meaning of the diagnostic and status indicators in the bus system function area (BUS in Figure 8-6 on page 8-9) of the modules, please refer to the corresponding documentation.

onlinecomponents.com

8.2.2 Indicators in the supply function area (PWR)

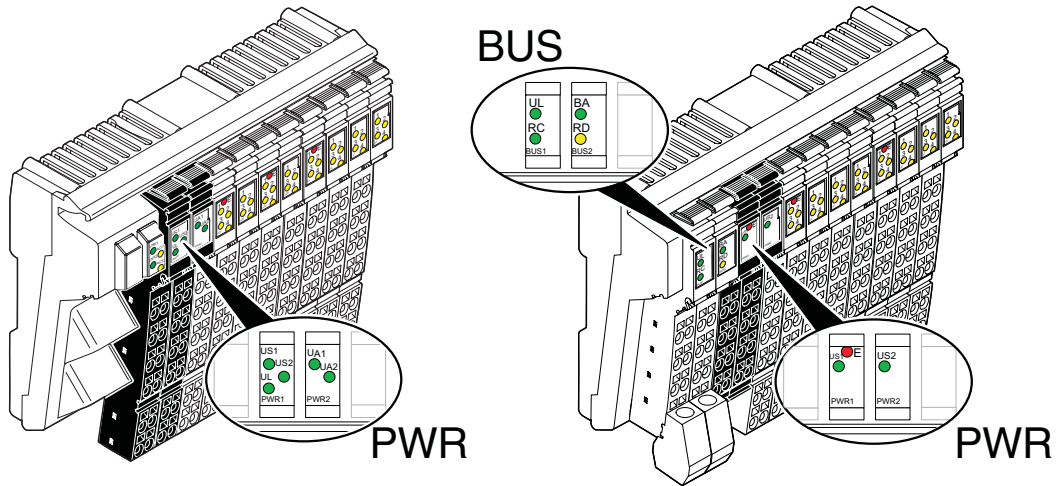

Figure 8-6 Possible indicators in the supply function area

6452A105

Diagnostics

The following states can be read on the Inline Block IO modules:

E	Red LED	Sensor supply undervoltage
	ON:	Sensor supply voltage too low
US	Green LED	Sensor supply
	ON:	Sensor supply present
	OFF:	Sensor supply not present
US1/2	Green LED	Sensor supply 1/2 (for connector ... to connector ... sensors)
	ON:	Sensor supply 1/2 present
	OFF:	Sensor supply 1/2 not present
UA	Green LED	Actuator supply
	ON:	Actuator supply present
	OFF:	Actuator supply not present
UA1/2	Green LED	Actuator supply 1/2 (for connector ... to connector ... actuators)
	ON:	Actuator supply 1/2 present
	OFF:	Actuator supply 1/2 not present
UL	Green LED	24 V communications power
	ON:	24 V communications power present
	OFF:	24 V communications power not present



The UL LED may be located in the supply (PWR) or bus (BUS) function area.

8.2.3 Indicators in the I/O function area (IN, OUT, IN/OUT)



The LEDs of the I/O function area are electrically located in the logic area. This may mean that the LED of an output is on but the output cannot be controlled due to an error between the logic area and the digital output. The LED does not monitor the output state. In the event of an error, the actual output state may differ from the state indicated by the LED.

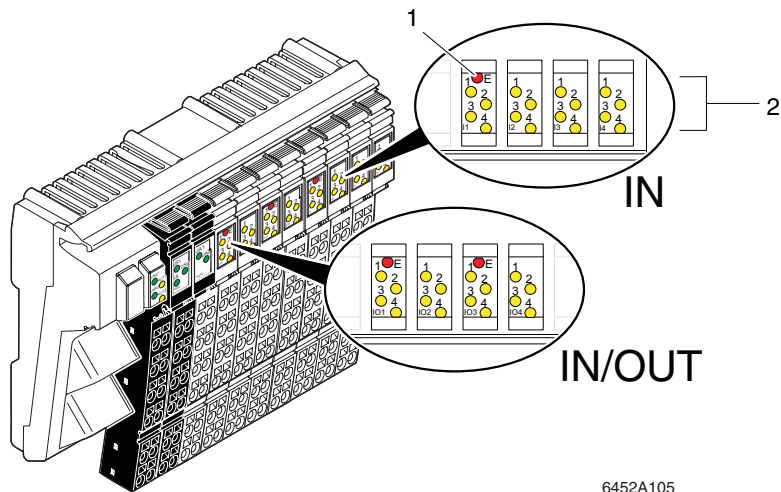

Figure 8-7 Indicators on I/O terminals

6452A105

Status

The status of the input or output can be read from the relevant yellow LED:

1, 2, 3, 4 (2)	Yellow LED	Status of the input/output
	ON:	Corresponding input/output set
	OFF:	Corresponding input/output not set
For terminals with extended diagnostics		
E (1)	Red LED	The meaning depends on the module. It is described in the module-specific data sheet, e.g.: Short circuit/overload of a sensor supply Short circuit at one or more outputs in the group
	ON:	An error has occurred
	OFF:	No error

Assignment between status LED and input/output

The figure shows the general principle of the assignment of a status LED to its input or output.

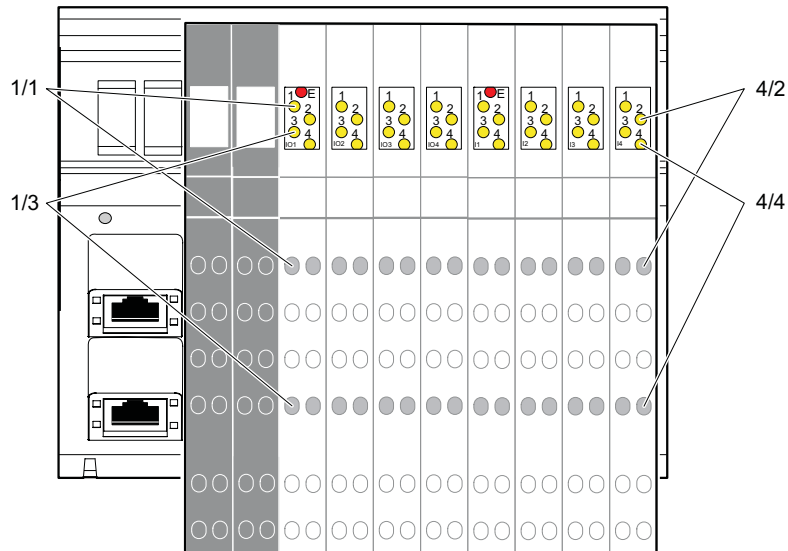

Figure 8-8 Assignment between status LED and input/output

Each slot in the LED area is labeled with the function, in Figure 8-8, e.g., IO1, IO2, ... I3, I4. The principle of assignment between the LED and terminal point is the same for all slots. For each slot with four inputs or outputs, the following LEDs are assigned to the following terminal points:

- LED 1 Terminal point 1.1
- LED 2 Terminal point 2.1
- LED 3 Terminal point 1.4
- LED 4 Terminal point 2.4

On the module in Figure 8-8, e.g., with 4/2, LED 2 on slot I4 is indicated. According to the data sheet, the LED belongs to input 30 at terminal point I4.2.1 (slot I4, terminal point 2.1).



For every module, the assignment is specified in the module-specific data sheet.

IL SYS INST UM E

onlinecomponents.com

9 Mounting/removing devices

9.1 Installation instructions

9.1.1 Unpacking

ESD regulations



NOTE: Electrostatic discharge

The devices contain components that can be damaged or destroyed by electrostatic discharge. When handling the devices, observe the necessary safety precautions against electrostatic discharge (ESD) according to EN 61340-5-1 and EN 61340-5-2.

Unpacking

All devices are supplied in an ESD bag.

Only qualified personnel should pack, unpack, mount, and remove the device while observing the ESD regulations.

9.1.2 Replacing a device

When replacing a device, please observe the following.

- In the SELV area:



NOTE: Disregarding this warning may result in malfunction

Do not replace devices while the power is connected.

Inline Modular IO:

Before removing or mounting a terminal, disconnect power to the entire station.

Make sure the entire station is reassembled before switching the power back on.

- In the low voltage area (**Inline Modular IO**):



WARNING: Dangerous contact voltage

Do not replace devices while the power is connected.

Before removing or mounting a terminal, disconnect power to the entire station.

Make sure the entire station is reassembled before switching the power back on.

9.2 Basic information about mounting

Mounting location

Modules and terminals of the Inline product range have IP20 protection and are therefore designed for use in a closed control cabinet or control box (terminal box) with IP54 protection or higher.

DIN rail

All Inline Block IO modules and Inline Modular IO terminals are mounted on 35 mm standard DIN rails.

The modules are mounted perpendicular to the DIN rail. This ensures that they can be easily mounted and removed even when space is at a premium.

The distance between DIN rail fasteners must not exceed 200 mm. This distance is necessary for the stability of the rail when mounting and removing devices.

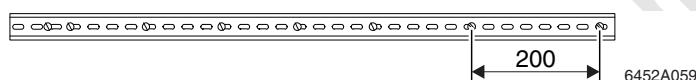

Figure 9-1 Fixing the DIN rail (in mm)

Mounting position

No specific mounting position is specified for the Inline Block IO modules or Inline Modular IO terminals. However, please refer to the ambient temperatures and any other special requirements (such as derating) specified in the data sheets.

Analog terminals are a special case. The accuracy data specified in the data sheets for these devices refers to the documented mounting position (usually horizontal DIN rail; Figure 9-2, detail A). The **typical tolerance values** for the relevant configurations are determined in this mounting position. Experience from previous testing indicates that the typical tolerances of analog terminals are slightly affected by the mounting position. This means that another mounting position is also possible in principle.

To ensure sufficient mechanical fixing for the Inline station or Inline Block IO module when mounting on a vertical DIN rail (Figure 9-2, detail B), we recommend the E/AL-NS 35 end clamp. This prevents the station or module from slipping down, particularly in the event of vibration.

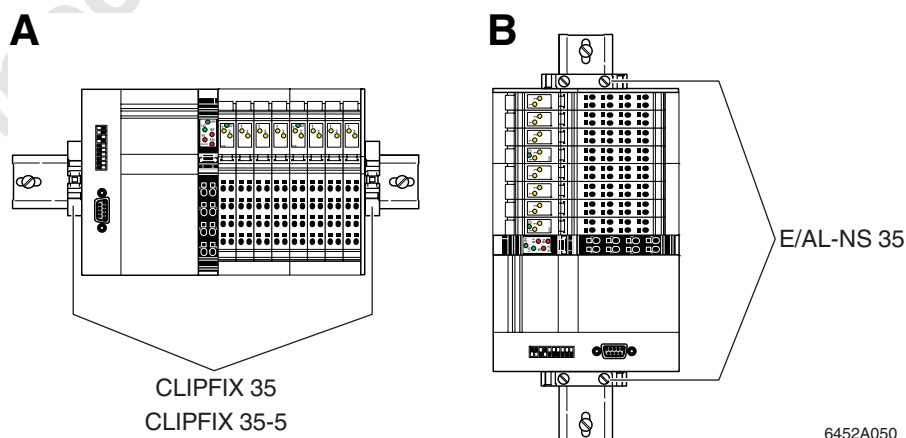

Figure 9-2 Mounting positions for an Inline station

9.3 Mounting distances

The space required for cable routing depends on the number of cables to be installed and must be left free on the left and/or right-hand side.

In order to minimize the parallel installation of signal and power supply lines, the cable duct on the left can be used for the signal and bus lines, for example, and the duct on the right for the power supply lines. This ensures that the parallel installation of these cable types is kept to a minimum and limits interference on the signal lines.

For the distances of the upper and lower cable ducts or the cable routing to the devices, please refer to the sections below.

9.3.1 Mounting distances for Inline Modular IO terminals

9.3.1.1 Mounting distances for terminals in the 24 V DC, 120 V AC, and 230 V AC areas (excluding terminals with fiber optic connections)

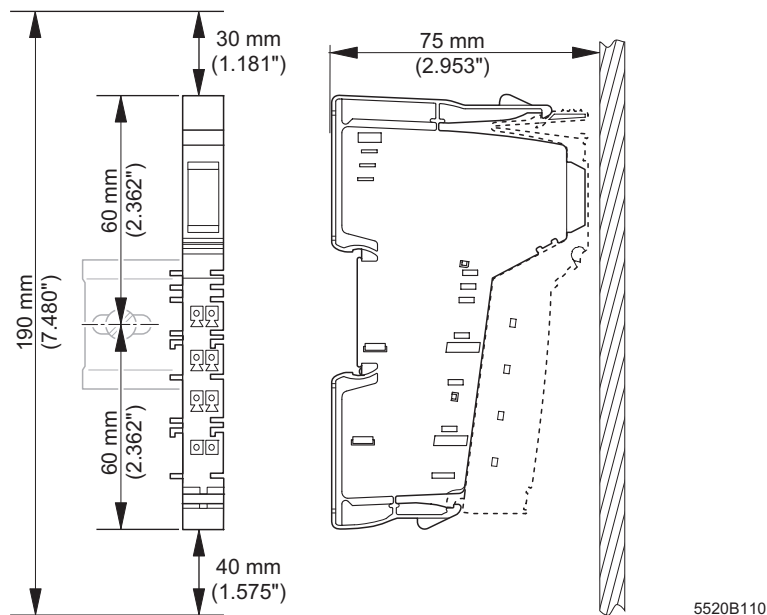

Figure 9-3 Mounting distances for terminals in the 24 V DC, 120 V AC, and 230 V AC areas



If the distances are smaller, the minimum bending radius of the cables, easy handling during installation, and a clear structure cannot be guaranteed.

9.3.1.2 Mounting distances for terminals with fiber optic connections

The bending radius and the space required for mounting terminals with fiber optic connections depends on the fiber optics used. Furthermore, the connector that is used affects the mounting distances.



Observe the instructions in the "IBS SYS FOC ASSEMBLY" fiber optic installation guidelines when determining the mounting distances.

According to the guidelines valid at the time of publication (Revision 03, 01/2007) the minimum bending radius for individual wires is 30 mm, and the minimum bending radius for a cable is either 50 mm or 65 mm depending on the cable. Using a fast connection connector with bend protection, for example, results in the following mounting distances:

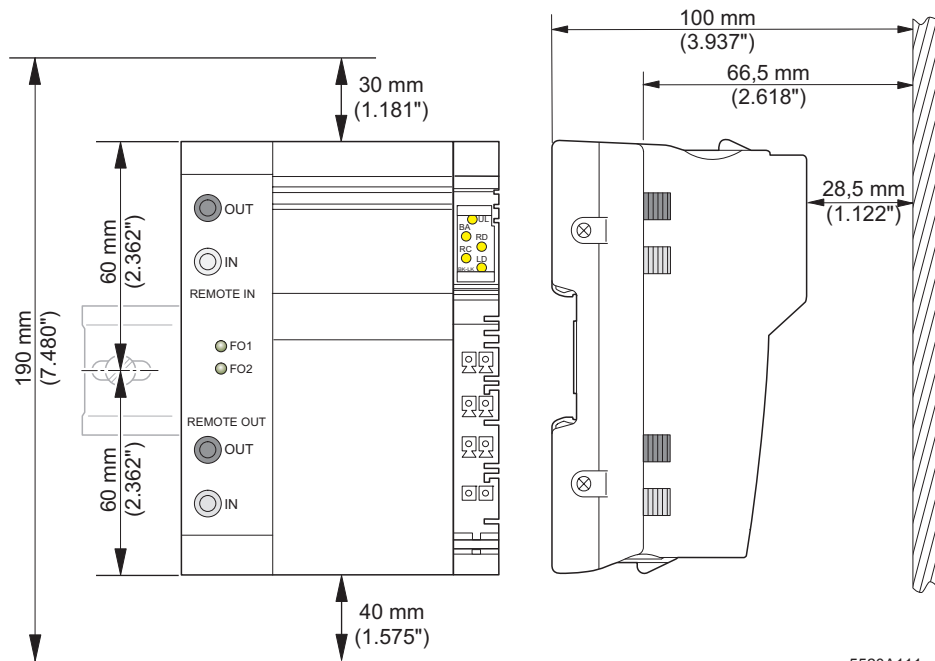

5520A111

Figure 9-4 Example mounting distances for the IBS IL 24 BK-LK-PAC bus coupler when using individual wires (bending radius 30 mm)

Mounting/removing devices

9.3.1.3 Mounting distances for power-level terminals



NOTE: Overheating

The minimum vertical mounting distances shown in Figure 9-5 must be observed for power-level terminals to ensure sufficient ventilation of the power-level terminals.



Ensure additional space for installing the cables.

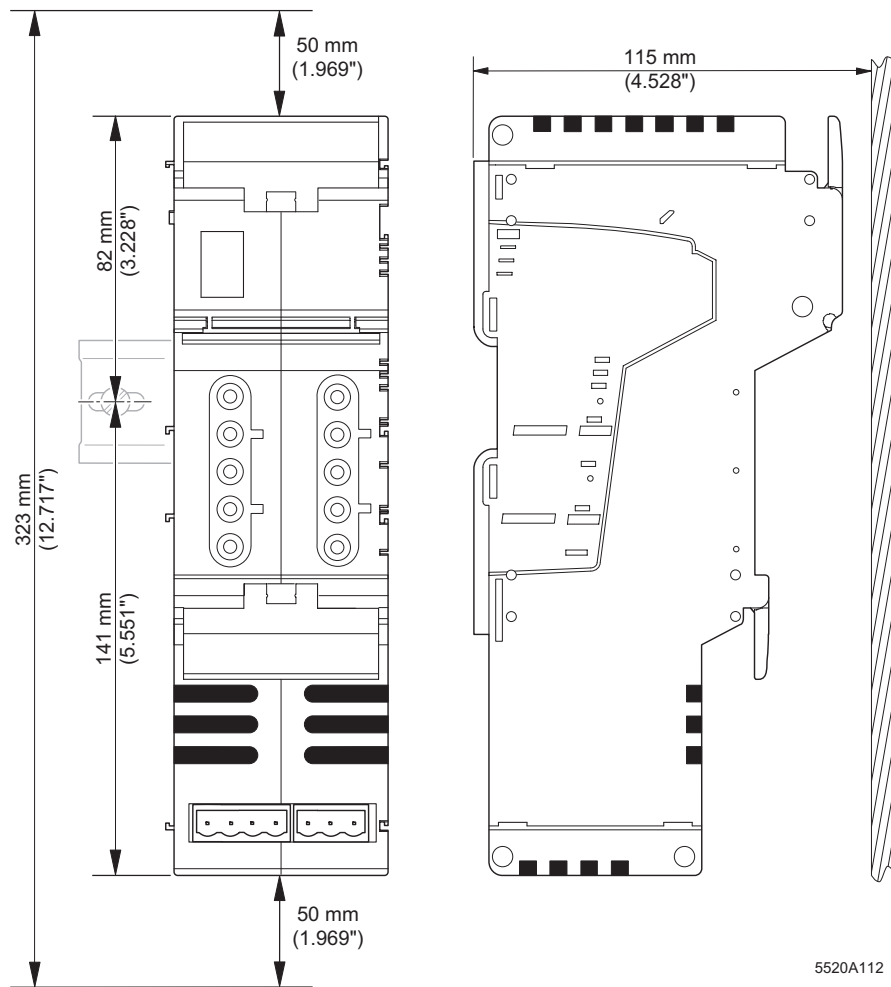

5520A112

Figure 9-5 Mounting distances for power-level terminals

9.3.1.4 Mounting distances for mounting outside a terminal box

If the Inline stations are housed, e.g., in a control cabinet rather than a terminal box, the DIN rail distances depend on the previously specified mounting distances and the particular configuration of the individual Inline stations. The possible mounting distances are shown in Figure 9-6.

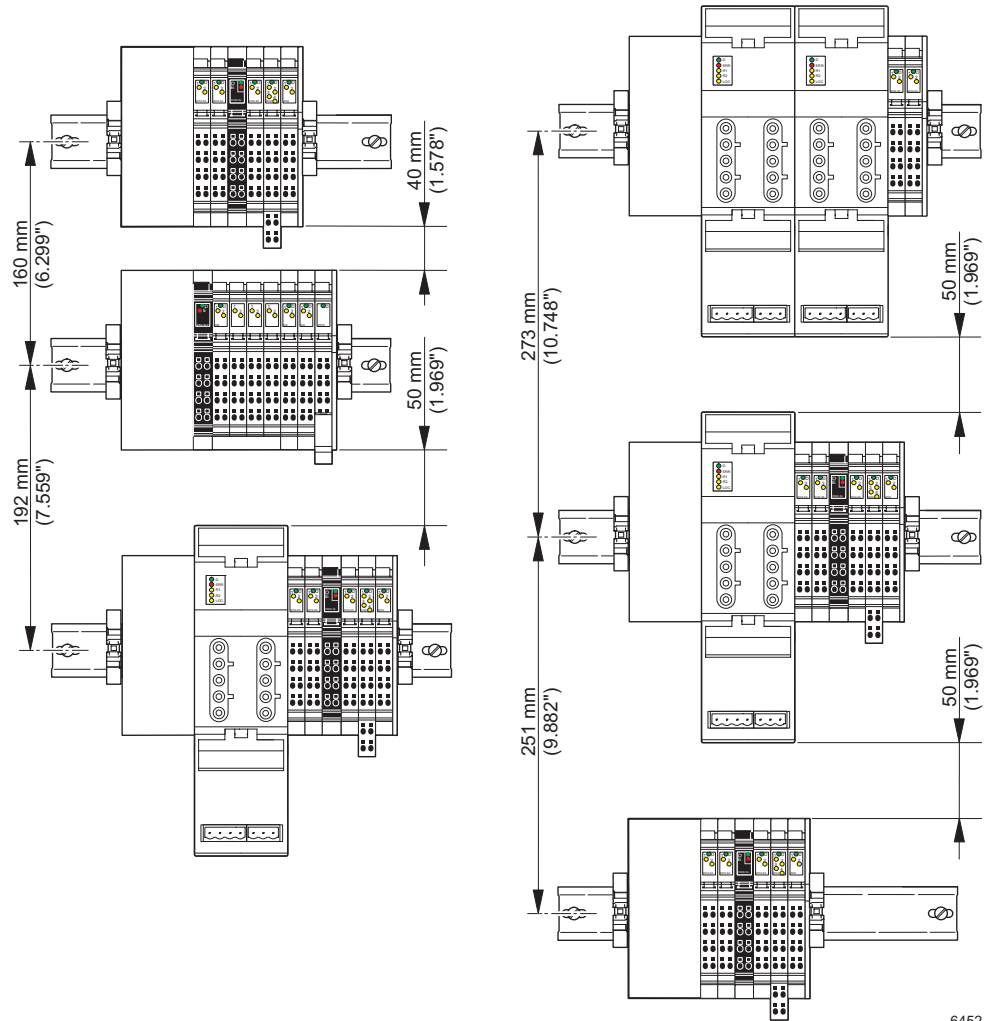

6452A005

Figure 9-6 Mounting distances for mounting outside the terminal box for different station structures

9.3.2 Mounting distances for Inline Block IO modules

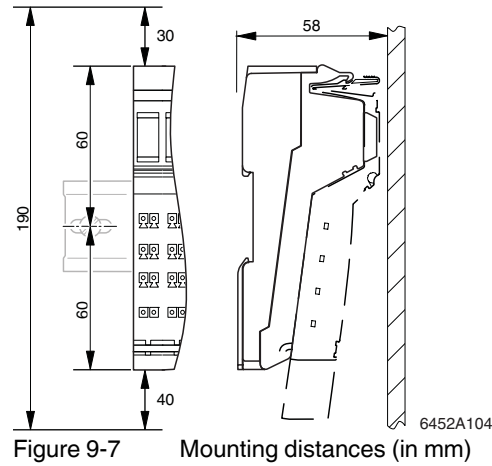

If the distances are smaller, the minimum bending radius of the cables, easy handling during installation, and a clear structure cannot be guaranteed.

9.4 Grounding concept



Within an Inline station, a distinction is made between functional earth ground (FE) and protective earth ground (PE).
For Inline Block IO modules, only functional earth grounding is used.

Protective earth grounding (PE)

Protective earth grounding protects people and machines against hazardous voltages. To avoid these dangers, correct installation, taking the local conditions into account, is vital.

Functional earth grounding (FE)

Functional earth grounding is used to improve noise immunity. All devices must be grounded so that any possible interference from data transmission paths is shielded and discharged to ground.

A 1.5 mm² wire must be used for grounding spring-cage terminals.

9.4.1 Functional earth ground (FE)

Functional earth ground is a low-impedance current path between circuits and ground. It is not designed as a safety measure but rather, for example, for the improvement of noise immunity.



Functional earth ground (FE) is only used to discharge interference. It does not provide shock protection for people.

Functional earth ground is used within the 24 V DC area (SELV).

To ensure reliable functional earth grounding of the station, various points must be observed.

Inline Modular IO

For Inline Modular IO terminals, functional earth ground is led from the grounded bus coupler through the 24 V DC area of the station using the FE potential jumper.

- 1 The bus coupler, power terminals, and segment terminals have an FE spring (metal clip) on the bottom of the electronics base. This spring establishes an electrical connection to the DIN rail. Use grounding terminals to connect the DIN rail to protective earth ground. The terminals are grounded when they are snapped onto the DIN rail.
- 2 Phoenix Contact also recommends grounding the Inline Modular IO bus coupler via the FE terminal point of the corresponding connector to ensure reliable functional earth grounding even if the DIN rail is dirty or the metal clip is damaged (see terminal-specific data sheet).
- 3 A 120 V AC or 230 V AC voltage area interrupts the FE potential jumper. Therefore, a 24 V DC power terminal, which is installed directly after such an area, must also be grounded via the FE terminal point (see terminal-specific data sheet).

Any additional Inline low-level signal terminals are automatically grounded via the FE potential jumper when they are properly installed.

The FE potential jumper is looped through the power-level terminals.

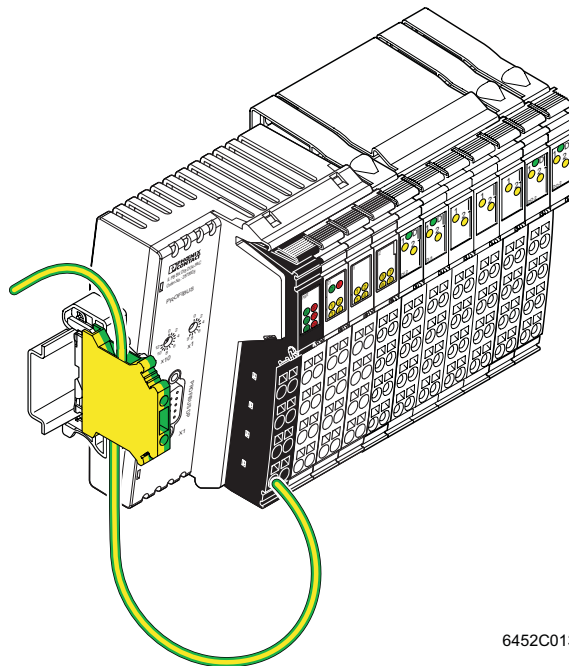

6452C013

Figure 9-8 Additional functional earth grounding of a bus coupler
(Example: IL PB BK DI8 DO4-PAC)



Figure 9-8 shows the additional grounding for a bus coupler using the example of the IL PB BK DI8 DO4-PAC bus coupler. Connect the additional grounding to your device according to the terminal-specific documentation.

Inline Block IO

- 1 The modules have an FE spring (metal clip) on the bottom of the electronics base. This spring establishes an electrical connection to the DIN rail. Use grounding terminals to connect the DIN rail to protective earth ground. The modules are grounded when they are snapped onto the DIN rail.
- 2 Phoenix Contact also recommends grounding the Inline Block IO module via the FE terminal point of the corresponding connector to ensure reliable functional earth grounding even if the DIN rail is dirty or the metal clip is damaged (see terminal-specific data sheet).

9.4.2 Protective earth ground (PE) (Inline Modular IO)

Protective earth ground is a low-impedance current path that minimizes the risk to the operator in the event of an error (including a high voltage and/or current error between an electrical circuit and ground).

In Inline terminals, protective earth ground is used outside the SELV.



WARNING: Disregarding this warning may result in the loss of electrical safety

Every power terminal of the 120 V AC or 230 V AC area must be connected to the DIN rail with low impedance, otherwise no protection is provided.

The PE (protective earth ground) potential jumper is led from the power terminal of the 120 V AC or 230 V AC area through this entire area to the next power terminal.

Power-level terminals are connected to PE using the power connector and voltage continuation between power-level terminals is ensured using the power bridge.

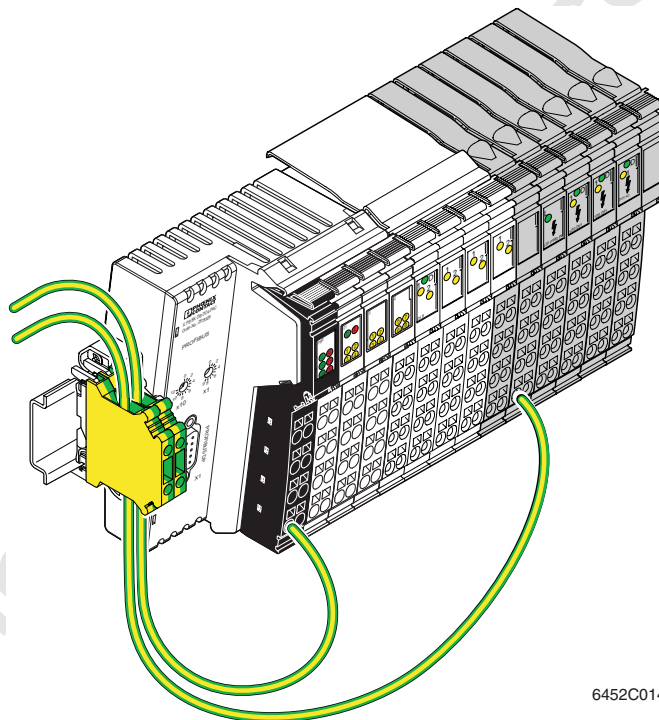

6452C014

Figure 9-9 Additional grounding of a bus coupler and protective earth ground connection
(Example: IL PB BK DI8 DO4-PAC)



Figure 9-9 shows the additional grounding and protective earth ground connection using the example of the IL PB BK DI8 DO4-PAC bus coupler. Connect the additional grounding and protective earth ground to your devices according to the terminal-specific documentation.

9.5 Shielding concept

Shielding is used to reduce the effects of interference on the system.

9.5.1 Inline shielding concept

In the Inline system, shielded cables are used with the following terminals:

- Remote bus cables
- Connecting cables
 - At terminals for analog signals (analog input, analog output, temperature recording)
 - At terminals for open and closed-loop control
 - At communication terminals
 - At detection terminals
 - At programmable terminals

Observe the following points when installing shielding:

- Secure the shielding so that as much of the braided shield as possible is held underneath the clamp of the shield connection.
- Make sure there is good contact between the connector and base.
- Do not damage or squeeze the wires.
- When connecting the shielding, observe the specifications for the connector wiring.

9.5.2 Shielding when connecting analog sensors and actuators

- Always connect analog sensors and actuators with shielded, twisted pair cables.
- Connect the shielding via the Inline connector with shield connection (see "Connecting shielded cables using an Inline shield connector" on page 10-2).



When connecting the cables, observe the instructions in the terminal-specific data sheets.

- As a rule, shielding must only be connected directly to the PE potential on one side. This is to prevent any occurrence of voltage equalization currents via the shielding.
- If necessary, integrate the shielding concept for analog I/O cables into the system concept, for example, it is useful to use a central FE shield connection at the control cabinet entry.

Example: Integration of analog shielding in a concept with central equipotential bonding at the control cabinet entry

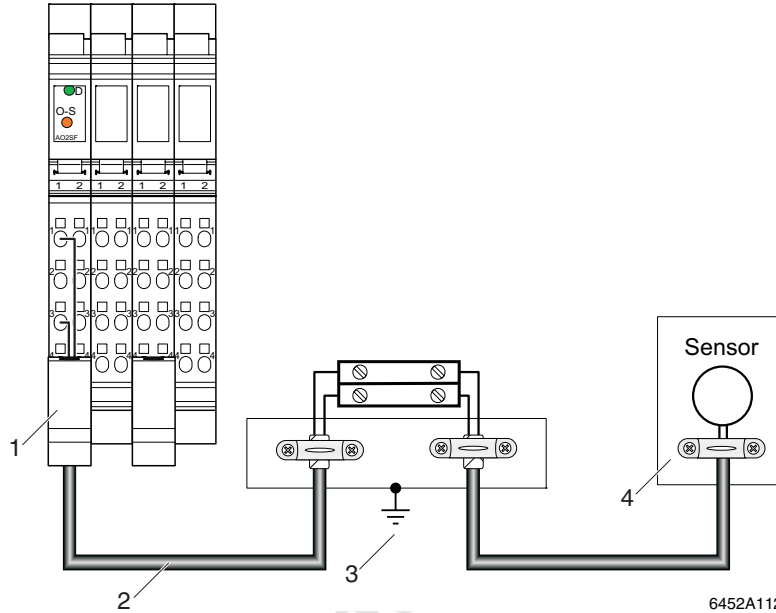

Figure 9-10 Integration of analog shielding in a concept with central equipotential bonding at the control cabinet entry

- 1 Lead the analog cable into the Inline connector making sure to maintain the cable insulation.
- 2 Use shielded twisted pair cables.
- 3 Connect the strain relief directly to PE potential.
Connect the shield for the entire analog transmission path to PE potential at just one point. In the example above, this point is the jumpering level (C).
- 4 Lead the sensor cable into the sensor making sure to maintain the cable insulation.



NOTE: Possible malfunctions

When integrating the shielding of analog I/O cables in an equipotential bonding concept, make sure that direct connection to the PE potential is only made at one point (e.g., at the central grounding point of the jumpering level).

9.6 Mounting/removal

9.6.1 Inline Modular IO: Mounting/removal

Mounting side by side (Inline Modular IO)

An Inline station is set up by mounting the individual components side by side. No tools are required. Mounting the components side by side automatically establishes the potential and bus signal connections between the individual station components.

After a station has been set up, individual terminals can be exchanged by pulling them out or plugging them in. Tools are not required.

End clamps (Inline Modular IO)

Mount end clamps on both sides of the Inline station. The end clamps ensure that the Inline station is correctly mounted. End clamps secure the Inline station on both sides and keep it from moving from side to side on the DIN rail. For the recommended end clamps, please refer to "Ordering data" on page 11-7.

When mounting on a horizontal DIN rail, the end clamps can be snapped onto the DIN rail at any point during station assembly.

When mounting on a vertical DIN rail, secure the end clamp on the left at the start of station assembly, so as to prevent the station from slipping down.

End plate (Inline Modular IO)

The end plate terminates an Inline station. It has no electrical function. It protects the station against ESD pulses and the user against dangerous contact voltages. The end plate is supplied with the bus coupler and does not have to be ordered separately.

Order of the Inline terminals

When mounting, observe the correct order of the Inline terminals (see "Order of the Inline Modular IO terminals" on page 9-22).

9.6.1.1 Mounting/removing/replacing terminals in the 24 V DC and 120 V AC/230 V AC areas

Mounting

When mounting a terminal in these areas, proceed as shown in Figure 9-11 on page 9-15:

- Disconnect the power to the station.
- First snap on the electronics base, which is required for mounting the station, perpendicular to the DIN rail (detail A).



When doing this ensure that **all** featherkeys and keyways on adjacent terminals are securely interlocked (detail B).

The keyway/featherkey connection links adjacent terminals together and ensures that data and potential routing is created safely.

- First, insert the data jumper for the bus interface in the guideways by snapping it onto the previous terminal (detail B1).



NOTE: Malfunction in the event of no contacting

Press gently against the adjacent terminal on the left to make sure that the featherkey has snapped into its keyway on the bus interface.

- Then insert the other potential jumpers into their guideways and snap the featherkeys into the corresponding keyways (detail B2).
- Detail C1 shows a common error. Here, the bus interface has not contacted properly. The featherkey is not in the keyway. The bus is not running or is running with errors ("loose contact").
- Detail C2 shows secure contacting of the data jumpers and the interlocking keyway/featherkey connection.
- Once all the bases have been snapped on, plug the connectors into the appropriate bases.
First, place the front connector shaft latching in the front snap-on mechanism (detail D1).
Then press the top of the connector towards the base until it snaps into the back snap-on mechanism (detail D2).



The keyways of an electronics base do not continue on a connector. When snapping on an electronics base, there must be no connector on the left-hand side of the base. If a connector is present, it will have to be removed.

Mounting/removing devices

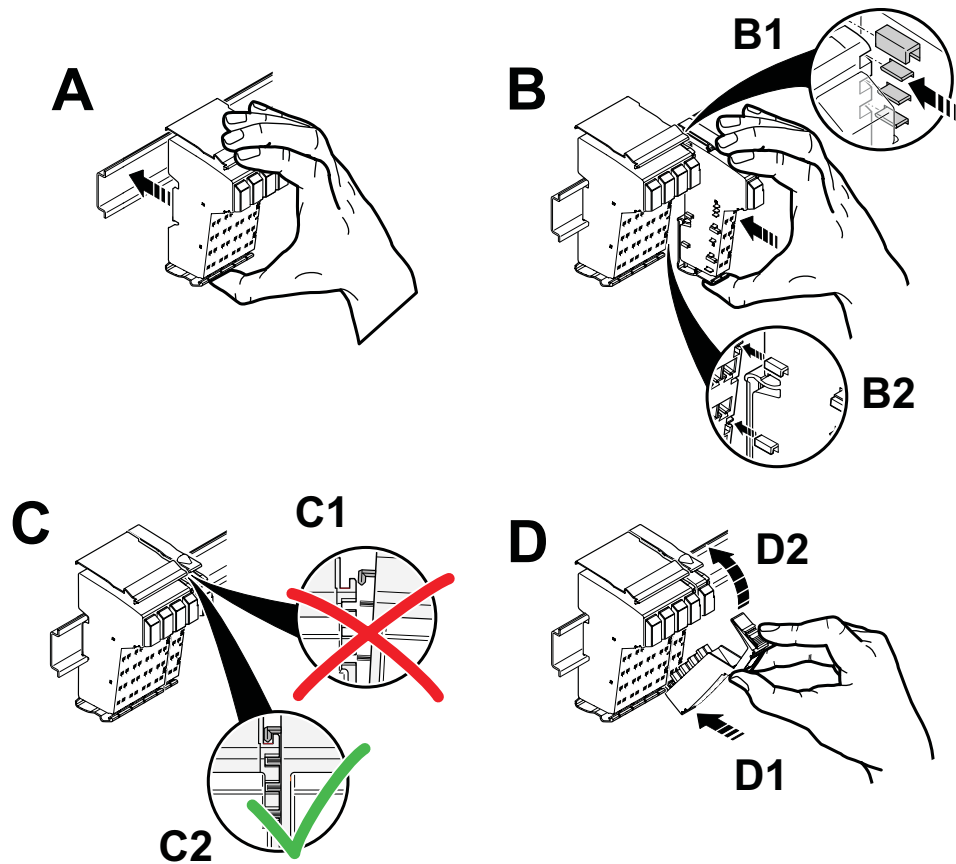

6452C010

Figure 9-11 Mounting a terminal

Removal

When removing a terminal, proceed as shown in Figure 9-12 on page 9-16:

- Disconnect the power to the station.
- If there is a labeling field, which covers several connectors, it may have to be removed (detail A1).



If a terminal has several connectors, all connectors of the terminal must be removed. The following describes how a 2-slot terminal is removed.

- Lift the connector of the terminal to be removed by pressing on the back connector shaft latching (detail A2).



When using extended double signal connectors (long connectors), please ensure that you do not bend them back too far, as you may break the front snap-on mechanism.

- Remove the connector (detail B).
- Remove the adjacent connectors of the neighboring terminals (detail C). This prevents the potential routing knife contacts and the keyway/featherkey connections from being damaged. You also have more space available for accessing the terminal.

IL SYS INST UM E

- Press the snap-on mechanism (detail D1), and remove the electronics base from the DIN rail by pulling the base straight back (detail D2). If you have not removed the connector of the adjacent terminal on the left, remove it now in order to protect the potential routing knife contacts and the featherkeys of the keyway/featherkey connection.

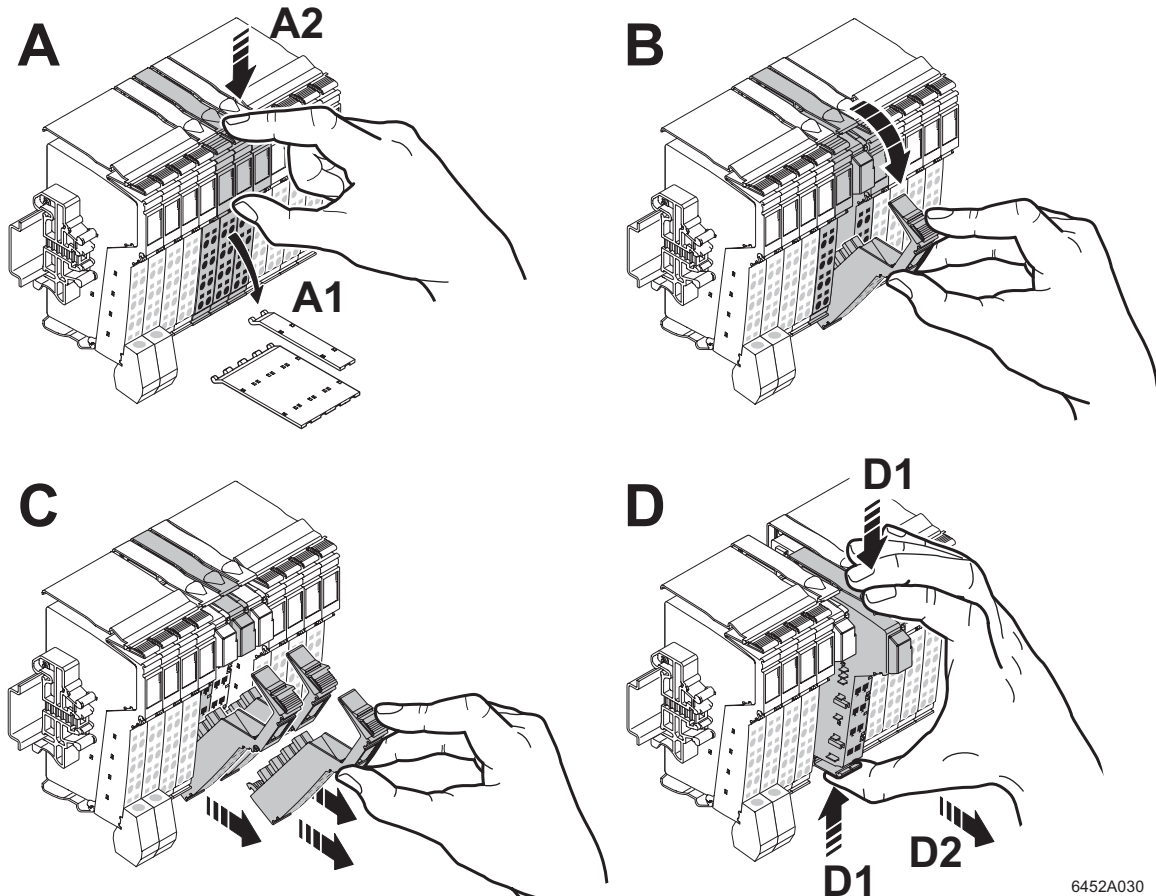

6452A030

Figure 9-12 Removing a terminal

Replacing a terminal

If you want to replace a terminal within the Inline station, follow the removal procedure described above. Do not snap the connector of the adjacent terminal on the left back on yet. Insert the base of the new terminal.



When doing this ensure that **all** featherkeys and keyways on adjacent terminals are securely interlocked.

Then reconnect all the connectors.



The top connector latching must click into place.

9.6.1.2 Replacing a fuse

The 24 V DC power and segment terminals are also available in versions with a fuse. If a fuse is not present or faulty, you must insert or replace it.



WARNING: Observe the following notes when replacing a fuse for the protection of your health and your system.

1. Use the screwdriver carefully to avoid injury to yourself or other persons.
2. Lift the fuse out at the metal contact. Do not lift the fuse out at the glass part as this may break it.
3. Carefully lift the fuse out at one side and remove it by hand. Make sure the fuse does not fall into your system.

When replacing a fuse, proceed as shown in Figure 9-13 on page 9-18:

- Lift the fuse lever (detail A).
- Insert the screwdriver behind a **metal contact** of the fuse (detail B).
- Carefully lift out the metal contact of the fuse (detail C).
- Remove the fuse by hand (detail D).
- Insert a new fuse (detail E).
- Push the fuse lever down again until it clicks into place (detail F).

IL SYS INST UM E

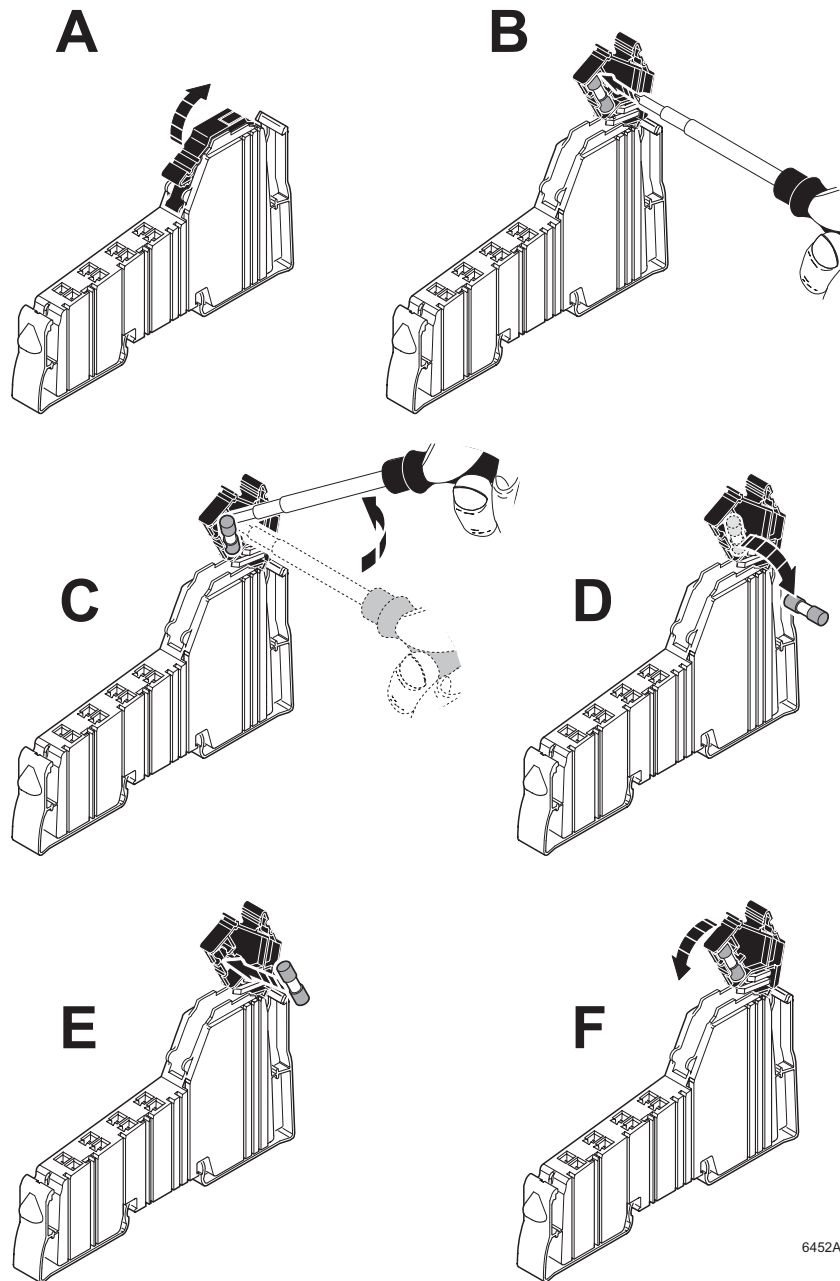

Figure 9-13 Replacing a fuse

Mounting/removing devices

9.6.1.3 Mounting/removing power-level terminals

Observe the following safety notes and warning instructions when working on power-level terminals.



WARNING: Dangerous contact voltage

Only work on power-level terminals and connectors when the power is disconnected.



Observe the safety notes and warning instructions provided in the terminal-specific data sheets.

Mounting

When mounting a power-level terminal, proceed as shown in Figure 9-14:

- Snap on the power housing, which is required for mounting the station, perpendicular to the DIN rail (detail A).



When doing this ensure that **all** featherkeys and keyways on adjacent terminals are securely interlocked.

The keyway/featherkey connection links adjacent terminals together and ensures that potential routing is created safely.



The keyways of an electronics base do not continue on the connector of terminals for the 24 V DC area. When snapping on a power housing, there must be no 24 V connector on the left-hand side of the housing. If a connector is present, it will have to be removed.

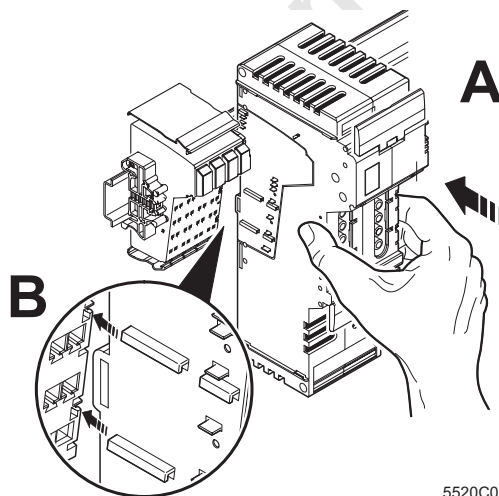

5520C088

Figure 9-14 Mounting a power-level terminal

- Next, attach the required connectors to the housing. The available connections are described in "Connections on a power-level terminal (Inline Modular IO)" on page 10-14.

IL SYS INST UM E

Removal

When removing a terminal, proceed as shown in Figure 9-15:

- If adjacent terminals belong to the 24 V DC or 120 V AC/230 V AC area: Remove the adjacent connectors of the neighboring terminals (Figure 9-12 on page 9-16). This prevents the potential routing knife contacts and the keyway/featherkey connection from being damaged.
- Lift the release flaps towards the center of the power-level terminal (Figure 9-15, detail A).
- Remove the power-level terminal by uniformly pulling the release flaps straight back from the DIN rail (detail B). If you have not removed the connector of the adjacent terminal on the left, remove it now in order to protect the potential routing featherkeys and the keyway/featherkey connection.

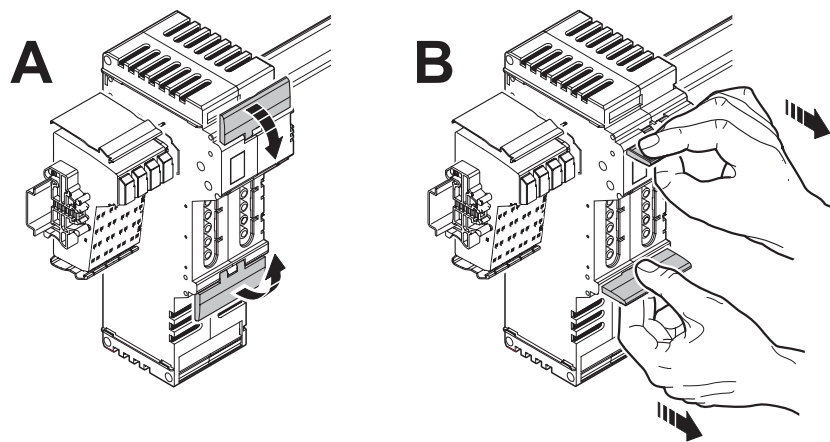

5520B089

Figure 9-15 Removing a power-level terminal

9.6.2 Inline Block IO: Mounting/removal

Mounting

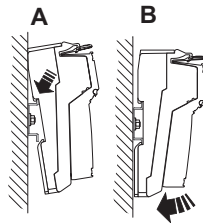

Figure 9-16 Snapping on the base

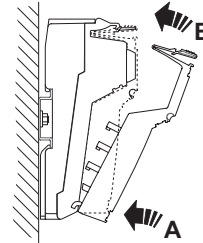

Figure 9-17 Snapping on a connector

- Place the base onto the DIN rail from above (Figure 9-16, A) and press down firmly (B).
- Plug the connectors into the base (Figure 9-17). First, insert the front connector shaft latching (A). Then press the top of the connector towards the base until it snaps into place (B).

Removal

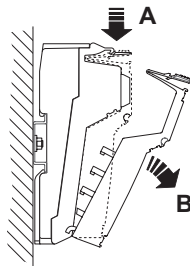

Figure 9-18 Removing a connector

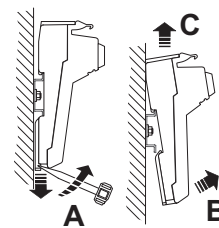

Figure 9-19 Removing the base

- Disconnect the power to the module.
- If there is a labeling field, which covers several connectors, it may have to be removed.



Before removing the base, disconnect all the necessary connectors, so as to provide access to the base latch.

When using extended double signal connectors (long connectors), please ensure that you do not bend them back too far, as you may break the front snap-on mechanism.

- Lift the connector that is to be removed by pressing on the back connector shaft latching (Figure 9-18, A).
- Remove the connector (B).
- Insert a tool in the base latch and pull gently upwards (Figure 9-19, A). Pull the module out from the DIN rail (B, C).

9.6.3 Order of the Inline Modular IO terminals

9.6.3.1 General order

The order of the terminals within an Inline station should depend on the current consumption of the I/O from the potential jumpers U_M and U_S .

As the voltage at every power terminal is reinjected into the potential jumpers U_M and U_S , the section (main circuit) between a bus coupler and a power terminal or between a power terminal and another power terminal must always be considered when calculating the current. If power terminals are not used, the entire station is a main circuit.

Within a main circuit, install the terminals according to their current consumption. Install the terminals with the highest current consumption first. This has the advantage that the high supply current does not flow through the entire main circuit and thus does not flow through all the terminals.

The following order is recommended.

Table 9-1 Order of the Inline terminals within a main circuit

	Function	Abbreviation in order designation	Function identification	Note
1	Digital output	DO, SDO	Pink, red, dark red	In descending order of current consumption
2	Digital input	DI, SDI	Light blue, blue, dark blue	In descending order of current consumption
3	Relay	DOR, SDOR	Dark red	
4	Power	ELR, MLR, EC AR, DC AR	Dark red	See also 9.6.3.4
5	Special functions		Orange	In descending order of current consumption
	– Open and closed-loop control	PWM, CNT, SSI, INC, TEMPCON		
	– Communication	RS, ASI MA, DALI		
	– Detection	INC-IN, SSI-IN, IMPULSE-IN		
– Safety	SAFE		Please observe any special requirements (subsequent safety-related segment circuit or subsequent power-level terminals).	
6	Analog output	AO	Yellow	In descending order of current consumption; see also 9.6.3.3
7	Analog input	AI, SGI, TEMP	Green	In descending order of current consumption; see also 9.6.3.3
		IB IL TEMP 2/UTH-PAC		

Please also observe the following notes:

- In the event of any further restrictions regarding the position of a terminal, please refer to the terminal-specific data sheet.
- For the current consumption of the terminals, please refer to the relevant terminal-specific data sheet.

9.6.3.2 Remote bus branch in an Inline station

If you want to integrate a remote bus branch into an Inline station, please note that the terminal with remote bus branch **must** be placed **directly** after a bus terminal, an Inline Controller or another terminal with remote bus branch.



Please refer to the corresponding data sheets to see if any other special requirements should be observed.

9.6.3.3 Positioning terminals for analog signals

High current flowing through potential jumpers U_M and U_S leads to a temperature rise in the potential jumpers and inside the terminal. This reduces the measuring accuracy and shortens the service life of the terminal.

To keep the current flowing through the potential jumpers of the analog terminals as low as possible, always place the analog terminals after all the other terminals at the end of the main circuit.



Within the analog terminals, position the IB IL TEMP 2/UTH-PAC terminal after **all** the other terminals to keep the current flowing through **all** the potential jumpers for this terminal as low as possible.

9.6.3.4 Positioning power-level terminals

In a 24 V DC area, position the power-level terminals anywhere in the main circuit, but before the analog terminals.

In a 24 V DC area, power-level terminals can be positioned anywhere in the main circuit before terminals with a special function and analog terminals. Due to noise emissions, power-level terminals with mechanical load relay (MLR) should be positioned away from analog terminals, i.e., they must not be placed adjacent to them.



Please note that only **adjacent** power-level terminals can be connected for potential jumpering using power bridges.

9.6.3.5 Example of the structure of a main circuit

Table 9-2 Example: Structure of a main circuit

Terminal	Type	Reason for position
1 IB IL 24 DO 16-PAC	Digital output terminal	DO, current higher than for 2; please observe note below table
2 IB IL 24 DO 2-PAC	Digital output terminal	DO
3 IB IL 24 DI 16-PAC	Digital input terminal	DI, current higher than for 4
4 IB IL 24 DI 2-PAC	Digital input terminal	DI
5 IB IL 400 MLR 1-8A	Power-level terminal	Any, before analog
6 IB IL CNT-PAC	Function terminal	
7 IB IL AO 2/SF-PAC	Analog output terminal	AO
8 IB IL TEMP 2/UTH-PAC	Analog input terminal	AI, after all others



NOTE:

In the event of high simultaneity of digital outputs and maximum current load, insert a power terminal after the IB IL 24 DO 16-PAC terminal.

If the maximum load of the outputs is 0.2 A, an additional power terminal is not required. This configuration is in Figure 9-20.

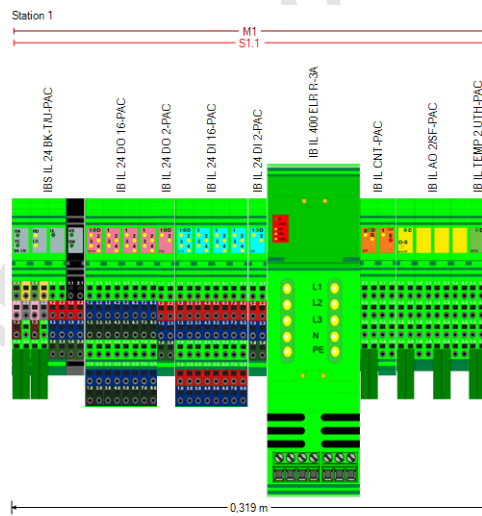

Figure 9-20 Suggested solution

10 Connecting cables

10.1 Connecting cables using Inline connectors

Excluding a few exceptions, the cables for the I/O and supply voltages are connected via Inline connectors using the spring-cage method. This means that signals up to 250 V AC/DC and 8 A can be connected with a conductor cross-section of 0.08 mm² to 1.5 mm².



Please observe the permissible lengths for sensor/actuator cables (see "Cable connection method/cross-section" on page 11-5 or terminal-specific data sheet).

Both shielded and unshielded cables are used with Inline Modular IO terminals or Inline Block IO modules.

10.1.1 Connecting unshielded cables

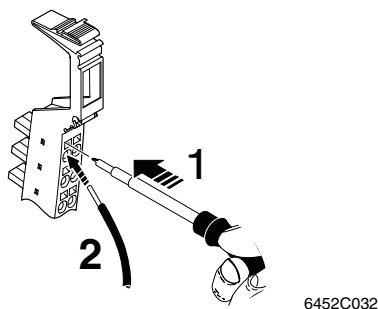

Figure 10-1 Connecting unshielded cables

Wire the connectors according to your application.



For the connector pin assignment, please refer to the corresponding terminal-specific data sheet.

When wiring, proceed as follows:

- Strip 8 mm off the cable.



Inline wiring is normally done without ferrules. However, it is possible to use ferrules. If using ferrules, make sure they are properly crimped.

- Push a screwdriver into the slot of the appropriate terminal point (Figure 10-1, detail 1), so that you can insert the wire into the spring opening. Phoenix Contact recommends using a SZF 1 - 0,6X3,5 screwdriver (Order No. 1204517; see Phoenix Contact "CLIPLINE" catalog).
- Insert the wire (Figure 10-1, detail 2). Remove the screwdriver from the opening. This clamps the wire.

Following installation, the wires and the terminal points should be labeled (see also "Function identification and labeling" on page 5-5).

10.1.2 Connecting shielded cables using an Inline shield connector

Shielded cables can be connected via IB IL SCN-6 SHIELD and IB IL SCN 6-SHIELD-TWIN shield connectors. The IB IL SCN-6 SHIELD shield connector is designed to connect one shielded cable. Two shielded cables can be easily connected via the IB IL SCN 6-SHIELD-TWIN shield connector. In principle, cables are connected via the shield connector in the same way as shown in Figure 10-2 on page 10-3 and Figure 10-3 on page 10-4.

Figure 10-2 shows the connection of a shielded cable using a remote bus cable as an example. In this example, the cables are twisted pair cables.

Figure 10-3 shows the connection of two shielded cables, using the wiring of the IB IL AI 2/SF-PAC terminal as an example. As two channels can be used here, the IB IL SCN 6-SHIELD-TWIN shield connector is used.

When connecting the cables proceed as shown in Figure 10-2 and Figure 10-3:

Stripping cables

- Strip the outer cable sheath to the desired length (a) (detail A).
The desired length (a) depends on the connection position of the wires and whether the wires should have a large or small amount of space between the connection point and the shield connection.
- Shorten the braided shield to 15 mm (detail A).
- Fold the braided shield back over the outer sheath (detail B).
- Remove the protective foil.
- Strip 8 mm off the wires (detail B).



Inline wiring is normally done without ferrules. However, it is possible to use ferrules. If using ferrules, make sure they are properly crimped.



When using twisted pair cables, keep the wire twisted until just before the terminal point.

Wiring the connectors

- Push a screwdriver into the actuation shaft of the appropriate terminal point (Figure 10-1 on page 10-1, detail 1), so that you can insert the wire into the spring opening.
Phoenix Contact recommends using a SZF 1 - 0,6X3,5 screwdriver (Order No. 12 04 51 7; see Phoenix Contact "CLIPLINE" catalog).
- Insert the wire (Figure 10-1 on page 10-1, detail 2). Remove the screwdriver from the opening. This clamps the wire.



For the connector pin assignment, please refer to the corresponding terminal-specific data sheet.

Connecting the shield

Figure 10-2 shows the shield connection for the IB IL SCN 6-SHIELD connector. The procedure for the IB IL SCN 6-SHIELD-TWIN connector (shown in Figure 10-3) is the same.

- Open the shield connection (detail C).

Connecting cables

- Check the position of the shield connection clamp in the shield connection (see also "Shield connection clamp" on page 10-5).
- Place the cable with the folded braided shield in the shield connection (detail D).
- Close the shield connection (detail E).
- Tighten the screws on the shield connection with a screwdriver (detail F).



To ensure that the shield connection clamp remains in place when the shield connection is closed, first secure the shield clamp with screws and then close the shield connection.

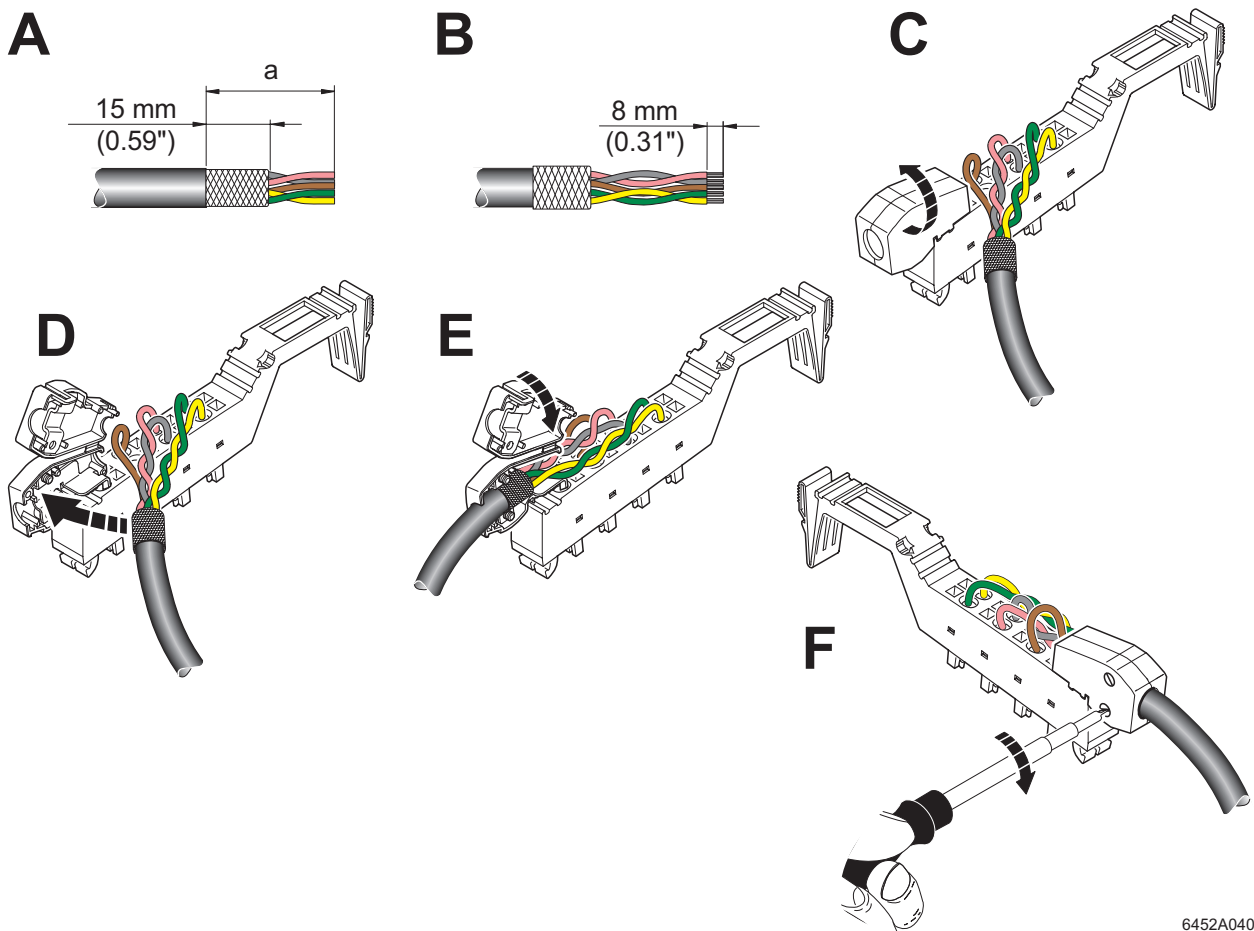

6452A040

Figure 10-2 Connecting a shielded cable via the IB IL SCN-6 SHIELD shield connector

IL SYS INST UM E

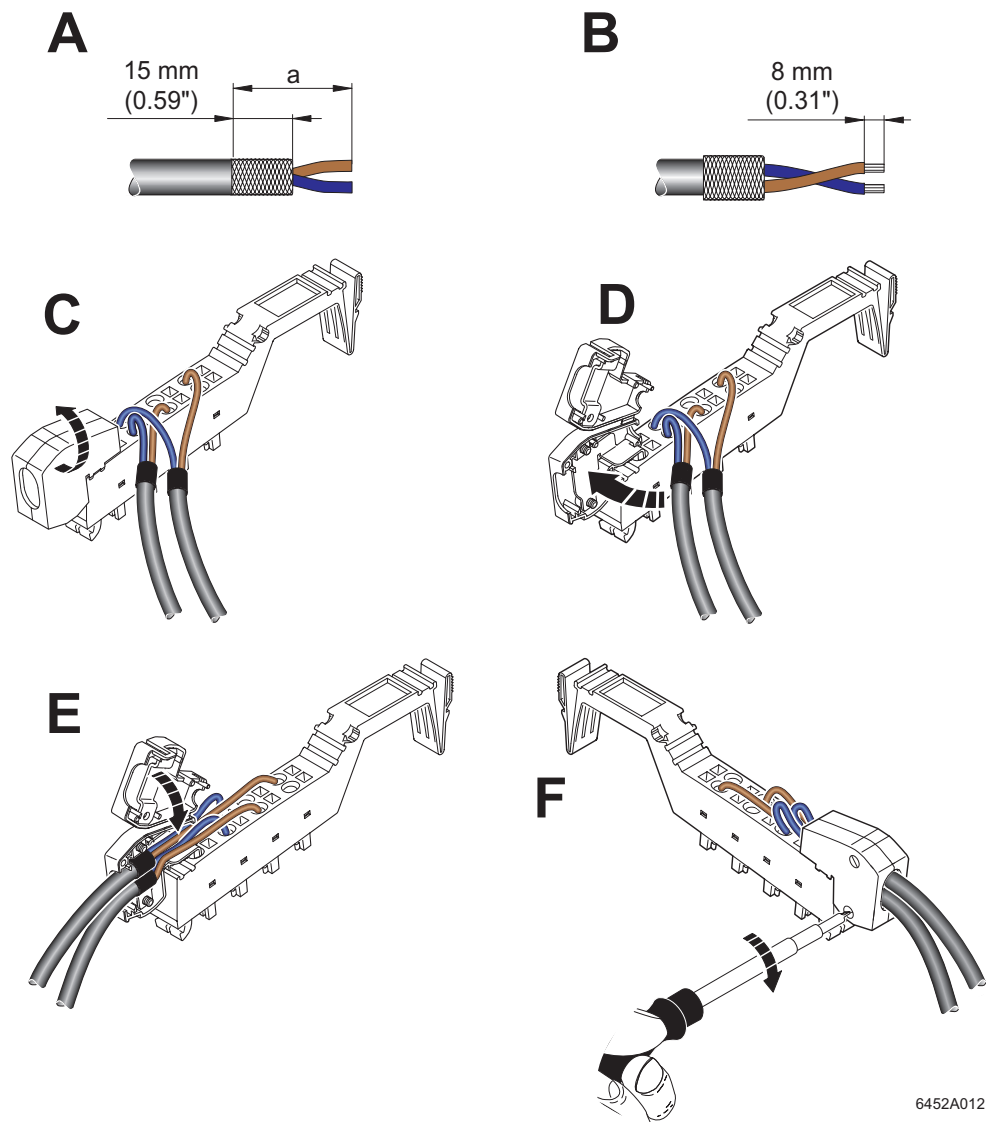

6452A012



Figure 10-3 Connecting two shielded cables via the IB IL SCN 6-SHIELD-TWIN shield connector

Connecting cables

Shield connection clamp

The shield connection clamp (a in Figure 10-4, detail B) in the shield connection can be used in various ways depending on the cable cross-section. For thicker cables (e.g., bus cable), the dip in the clamp must be turned away from the cable (Figure 10-4, detail B). For thinner cables, the dip in the clamp must be turned towards the cable (Figure 10-4, detail F).

If you need to change the position of the shield connection clamp, proceed as shown in Figure 10-4:

- Open the shield connection housing (detail A).
- The shield connection is delivered with the clamp positioned for connecting thicker cables (detail B).
- Remove the clamp (detail C), turn it to suit the cross-section of the cable (detail D), then reinsert the clamp (detail E).
- Detail F shows the position of the clamp for a thin cable.

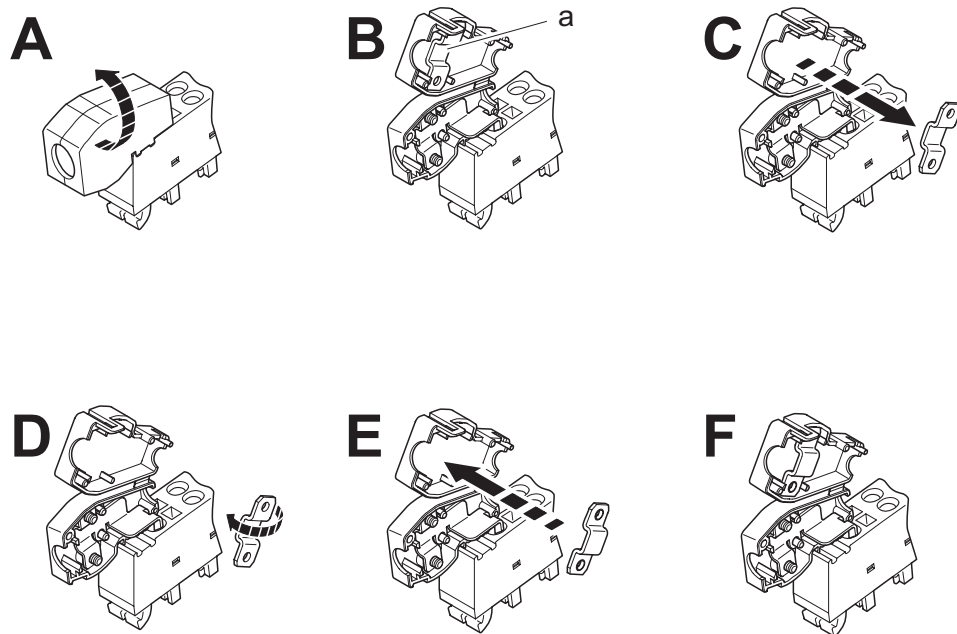

6452A033

Figure 10-4 Shield connection clamp alignment

10.2 Connecting the power supplies

Inline Modular IO

To operate an Inline station you must provide the supply voltage for the bus coupler, the logic of the terminals, and the sensors and actuators.

Connect the power supplies using unshielded cables as described in "Connecting unshielded cables" on page 10-1.



For the connector pin assignment of the supply voltage connections, please refer to the terminal-specific data sheets for bus couplers, power terminals, and segment terminals.

Inline Block IO

When using Inline Block IO modules, the supply voltage for the module and the sensors and actuators must be provided. Depending on the module, connection can be via Inline connector or COMBICON connector.

The power supplies are connected using unshielded cables. For connection via Inline connector, see "Connecting unshielded cables" on page 10-1.



For the connector pin assignments for connecting supply voltages, please refer to the relevant module-specific data sheet.

10.2.1 Inline Modular IO: Supply options

Bus coupler supply



For detailed information, please refer to the documentation for your bus coupler.

Power terminal supply

Depending on the type of power terminal, the following supply voltages can be supplied or provided:

- U_M and U_S (I/O supply voltage)
- U_{24V} (generation of U_L and U_{ANA}), U_M , and U_S (communications power and I/O supply voltage)



Please also refer to the information provided in "Power, segment, and accessory terminals" on page 4-4.

Providing the segment voltage at segment terminals

At segment terminals, the segment voltage U_S is provided from the main circuit U_M .



Please also refer to the information provided in "Power, segment, and accessory terminals" on page 4-4.

Notes on supply voltages

The bus coupler supplies the module electronics of the connected terminals with communications power (U_L), which is generated, for example, from the bus coupler supply voltage (U_{BK}). If the supply voltage U_{BK} is disconnected, the bus stops.

Connecting cables

The supply voltage to the sensors and actuators (U_M/U_S) should be installed and protected independently of the bus coupler supply (U_{BK}). In this way the bus continues to run even if some I/O devices are switched off.

10.2.2 Power supply requirements



WARNING: Dangerous contact voltage
Only use power supply units that ensure safe isolation between the primary and secondary circuits according to EN 50178.



For additional power supply requirements, please refer to the documentation for your bus coupler and the power terminals.

Inline Modular IO: Supply voltage requirements that differ from the system specifications

The specifications for Inline system supply voltages are described in "Technical data for Inline Modular IO" on page 11-1. However, some terminals have specific requirements. Therefore, always refer to the corresponding data sheet.

This section provides information about the various possible requirements within an Inline system.

Table 10-1 Supply voltage requirements of various products

	Inline (system requirements)	IB IL 400 MLR 1-8A	IB IL 24 SAFE 1-PAC IB IL 24 SAFE 2
Nominal voltage	24 V DC	24 V DC	24 V DC
Ripple	±5%	±5%	±5%
Permissible voltage range (including ripple)	19.2 V DC to 30.0 V DC	19.2 V DC to 28.8 V DC	20.4 V DC to 27.6 V DC
Documented in	"Technical data for Inline Modular IO" on page 11-1	Data sheet	Data sheet



If you are using Inline in a system with other product ranges, also observe the technical data for these product ranges. Please refer to the corresponding documentation for this technical data.

Two options are available when using terminals, which have special requirements regarding the power supply:

- 1 Observe the specific parameters for the power supply in the entire system.
- 2 Observe the specific parameters in the main circuit where the terminals are located.

10.3 Connecting the bus

The bus cable for your system is connected directly to the module in the case of Inline Block IO and to a bus coupler in the case of Inline Modular IO. Table 10-2 below lists the basic options for connecting the bus.

Table 10-2 Connection options for the individual fieldbus systems

Fieldbus	Connection method (to the Inline Block IO module or the Inline Modular IO bus coupler)	Connection is available	
		Inline Modular IO	Inline Block IO
PROFINET IO	RJ45 female connector	Yes	Yes
	SCRJ female connector	Planned	No
INTERBUS	Inline shield connector	Yes	Yes
	9-pos. D-SUB female connector/ 9-pos. D-SUB male connector	Yes	Yes
	F-SMA female connector	Yes	No
	E2000 female connector	Yes	No
PROFIBUS DP	9-pos. D-SUB female connector	Yes	Yes
Ethernet/IP	RJ45 female connector	Yes	–
Ethernet TCP/IP	RJ45 female connector	Yes	Yes
Modbus/TCP	RJ45 female connector	Yes	Yes
Modbus/RTU	9-pos. D-SUB female connector	Yes	–
SERCOS II	F-SMA female connector	Yes	–
SERCOS III	RJ45 female connector	Yes	Yes
DeviceNet™	2 x 5-pos. TWIN-COMBICON male connectors	Yes	Yes
CANopen	2 x 5-pos. TWIN-COMBICON male connectors	Yes	No
	9-pos. D-SUB female connector	No	Yes
Mechatrolink	USB type A	Yes	–
Bluetooth	Radio, antenna connection with SMA female connector	–	Yes

Key:

- Yes Connection method is available
- Planned Connection method is not available at present, but is planned
- No Connection method is not available at present
- No devices are available at present for this bus system



Connect the fieldbus according to the documentation for your Inline Block IO module or Inline Modular IO bus coupler.

10.4 Connecting sensors and actuators

Sensors and actuators are connected using connectors. The relevant terminal-specific data sheet indicates which connector(s) can be used for which terminal.

Connect the unshielded cables as described in "Connecting unshielded cables" on page 10-1.

Connect the shielded cables as described in "Connecting shielded cables using an Inline shield connector" on page 10-2.

10.4.1 Connection methods for sensors and actuators

Most of the digital I/O terminals in the Inline product range support the connection of sensors and actuators in 1, 2, 3 or 4-wire technology.

Because of the different types of connectors, a single connector can support the following connection methods:

- 8 sensors or actuators in 1-wire technology
- 2 sensors or actuators in 2, 3 or 4-wire technology
- 4 sensors or actuators in 2 or 3-wire technology
- 2 sensors or actuators in 2 or 3-wire technology with shield (for analog sensors or actuators)



When connecting analog devices, please refer to the terminal-specific data sheets, as the connection method for analog devices differs from that for digital devices.

10.4.2 Connections used for digital input and output terminals

Different connection options are described below using 24 V DC terminals as an example. For the 120 V AC/230 V AC area, the data changes accordingly. A connection example is provided in the relevant terminal-specific data sheet.

Table 10-3 Overview of the connections used for digital input terminals

Connection	Representation in the figure	1-wire	2-wire	3-wire	4-wire
Sensor signal IN	IN	X	X	X	X
Sensor supply U_S/U_M	$U_S (+24 V)$	-	X	X	X
Ground GND	GND (\perp)	-	-	X	X
Ground/FE shielding	FE ()	-	-	-	X

X Used
- Not used

Table 10-4 Overview of the connections used for digital output terminals

Connection	Representation in the figure	1-wire	2-wire	3-wire	4-wire
Actuator signal OUT	OUT	X	X	X	X
Actuator supply U_S	$U_S (+24 V)$	-	-	-	X
Ground GND	GND (\perp)	-	X	X	X
Ground/FE shielding	FE ()	-	-	X	X

X Used
- Not used



In the following diagrams, U_S is the supply voltage because this potential jumper is accessed in the majority of terminals. The relevant terminal-specific data sheet specifies whether the I/O is supplied from the main circuit U_M or the segment circuit U_S .

10.4.3 The various connection methods for sensors and actuators

1-wire technology

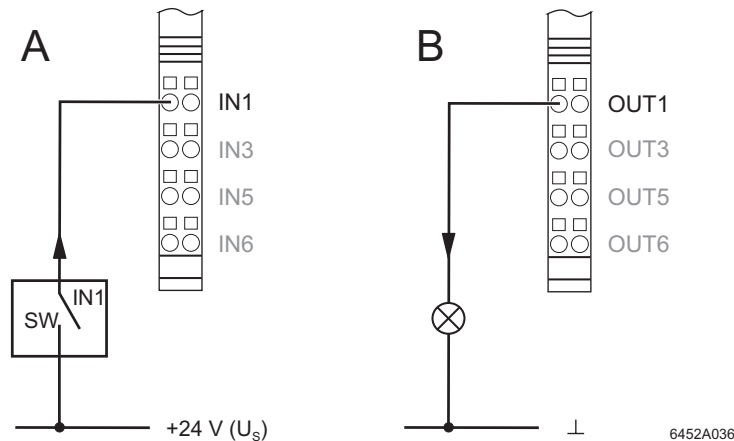

Figure 10-5 1-wire termination for digital devices

Sensor

Figure 10-6, detail A, shows the detection of a sensor signal schematically. The SW switch provides the input signal. The sensor signal is led to terminal point IN1. The sensor is supplied by the voltage U_S .



NOTE: Malfunction due to potential shifts

Supply the sensors and U_S of the Inline station from the same power supply. Make sure that there is at least one common GND as reference potential.

This will prevent potential shifts, which can have undesirable effects on the function of the station.

Actuator

Figure 10-6, detail B, shows the connection of an actuator. The actuator is supplied by output OUT1. The load is switched directly via the output.



NOTE: Malfunction due to potential shifts

Make sure that GND of the actuators and GND of the supply voltage U_S , which supply the actuators, have the same potential.

This will prevent potential shifts, which can have undesirable effects on the function of the station.



At the time of going to print, the IB IL 24 DI 32-PAC and IB IL 24 DO 32-PAC Inline terminals are designed to connect sensors and actuators in 1-wire technology. For connection examples, please refer to the corresponding data sheets.

IL SYS INST UM E

2-wire technology

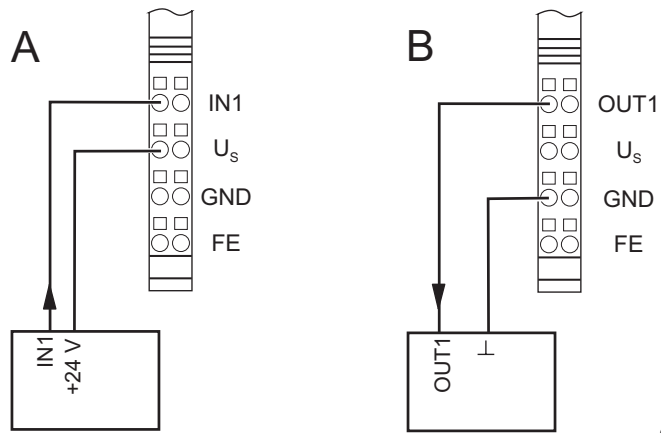

6452A021

Figure 10-6 2-wire termination for digital devices

Sensor

Figure 10-6, detail A, shows the connection of a 2-wire sensor. The sensor signal is led to terminal point IN1. The sensor is supplied by the voltage U_s .

Actuator

Figure 10-6, detail B, shows the connection of an actuator. The actuator is supplied by output OUT1. The load is switched directly via the output.

3-wire technology

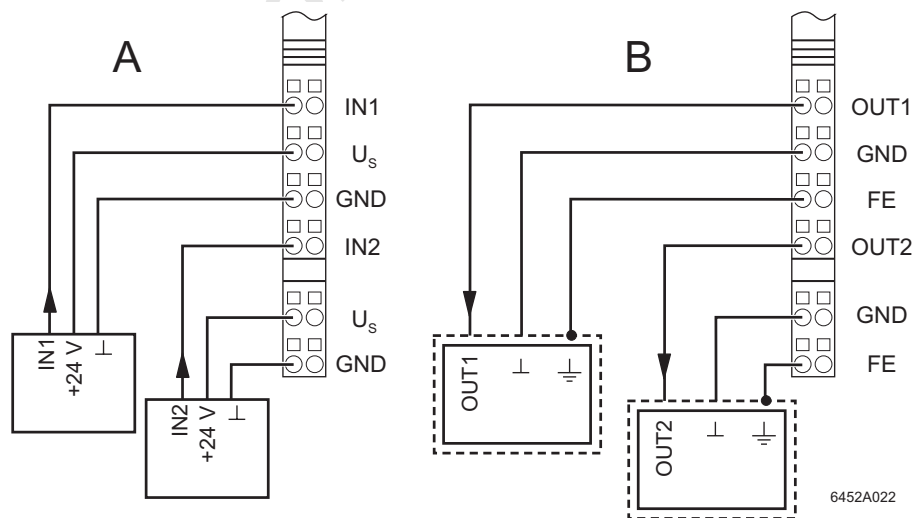

6452A022

Figure 10-7 3-wire termination for digital devices

Sensor

Figure 10-7, detail A, shows the connection of a 3-wire sensor. The sensor signal is led to terminal point IN1 (IN2). The sensor is supplied via terminal points U_s and GND.

Actuator

Figure 10-7, detail B, shows the connection of a shielded actuator. The actuator is supplied by output OUT1 (OUT2). The load is switched directly via the output.

4-wire technology

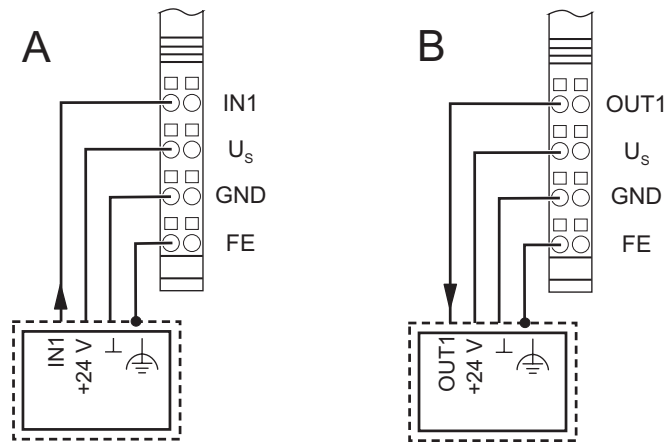

6452A023

Figure 10-8 4-wire termination for digital devices

Sensor

Figure 10-8, detail A, shows the connection of a shielded 3-wire sensor. The sensor signal is led to terminal point IN1. The sensor is supplied via terminal points U_s and GND. The sensor is grounded via the FE terminal point.

Actuator

Figure 10-8, detail B, shows the connection of a shielded actuator. The provision of the supply voltage U_s means that even actuators that require a separate 24 V supply can be connected directly to the terminal.

10.5 Connections on a power-level terminal (Inline Modular IO)



WARNING: Dangerous contact voltage

Only connect and remove the connectors of a power-level terminal when the mains voltage is disconnected and cannot be switched on again.

A power-level terminal has slots for the following connections:

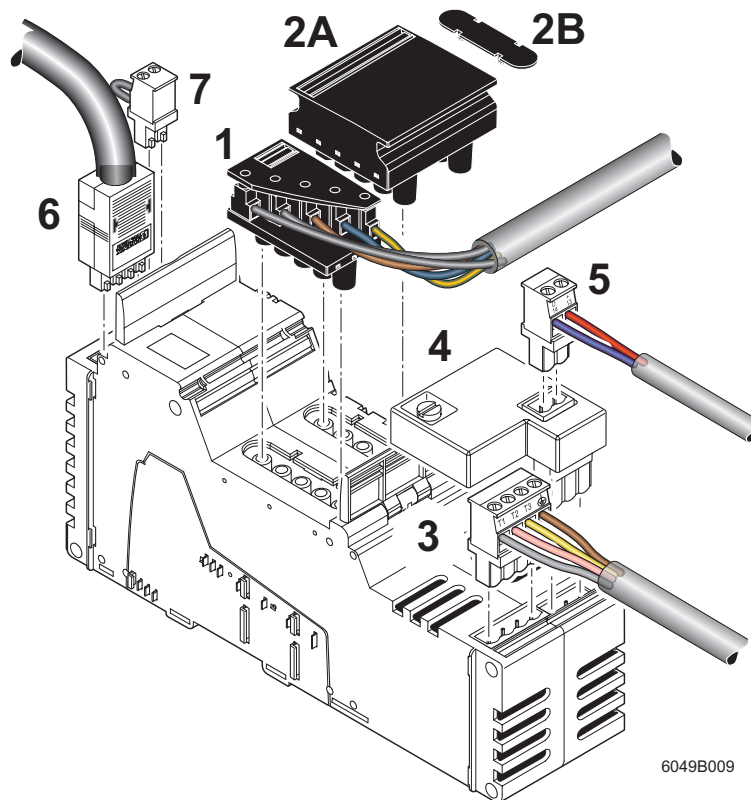

Figure 10-9 Power-level terminal with all possible connectors

Table 10-5 Slots and connectors of a power-level terminal

No. in Figure 10-9	Slot	Connector/connection
1	X11	Incoming mains (here: power connector)
2	X12	Outgoing mains (power bridge (2A) or cover (2B))
3	X10	Motor output
4	X8	Brake module (including brake switch and connection for brake)
5	X9	Connection of the brake to the brake module
6	X32	Hand-held operator panel connection (hand-held operator panel mode)
7	X18	Enable power level

10.5.1 Connecting or forwarding the incoming mains



WARNING: Dangerous contact voltage

Only remove or insert the power connector or the power bridge when the mains voltage is disconnected.

There are two ways of connecting the incoming mains to a power-level terminal:

You can connect the incoming mains using a power connector.

When assembling the power connector, proceed as shown in Figure 10-10:

- Strip approximately 80 mm off the cable sheath (detail A) and 7 mm off the wires (detail B). Fit the wire ends with ferrules.
- Connect the wires to the connector (detail C). The assignment is shown in Figure 10-11.

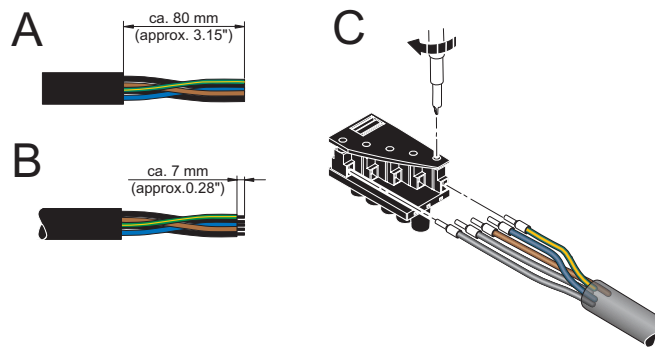

6452A035

Figure 10-10 Assembling a power connector

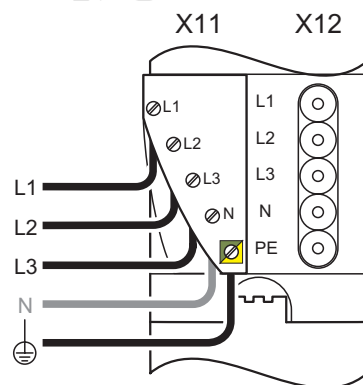

6453A007

Figure 10-11 Power connector assignment

X11 Incoming mains

X12 Outgoing mains



The PEN conductor (N) is not required for power-level terminals. However, the connectors offer the option of connecting and forwarding the PEN conductor.

Insert the assembled connector into connection X11 (Figure 10-11) of the power-level terminal (Figure 10-12).

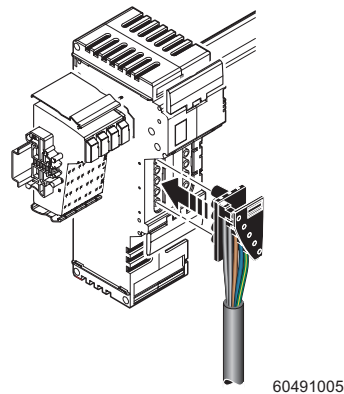

Figure 10-12 Connecting a power connector

You can forward the mains supply using a power bridge.

If several power-level terminals are connected one after the other, a power-level terminal can be connected to the preceding power-level terminal using a power bridge. If the preceding terminal is supplied with voltage, this voltage is led via the power bridge.

- Insert the power bridge on two adjacent power-level terminals so that connection X12 (outgoing mains) of the preceding terminal is connected to connection X11 (incoming mains) of the following terminal. The power bridge can carry a maximum of 20 A.

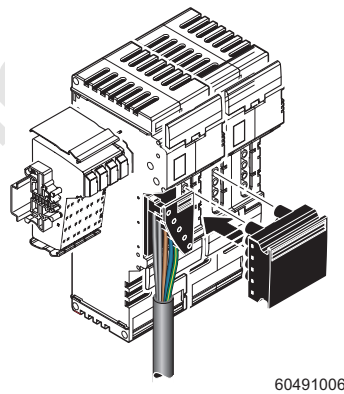

Figure 10-13 Inserting a power bridge

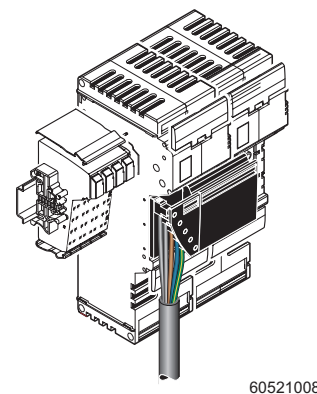

Figure 10-14 Power-level terminals with a mains connector and power bridge

10.5.2 Connecting the motor circuit connector



WARNING: Dangerous contact voltage

Only connect or remove the motor circuit connector when the mains voltage is disconnected.

The motor output is connected via a 4-pos. HV-COMBICON connector.

When assembling the motor circuit connector, proceed as shown in Figure 10-15:

- Strip approximately 30 mm off the cable sheath (detail A) and 7 mm off the wires (detail B). Fit the wire ends with ferrules.
- Connect the wires to the connector (detail C). The pin assignment is shown in Table 10-6.

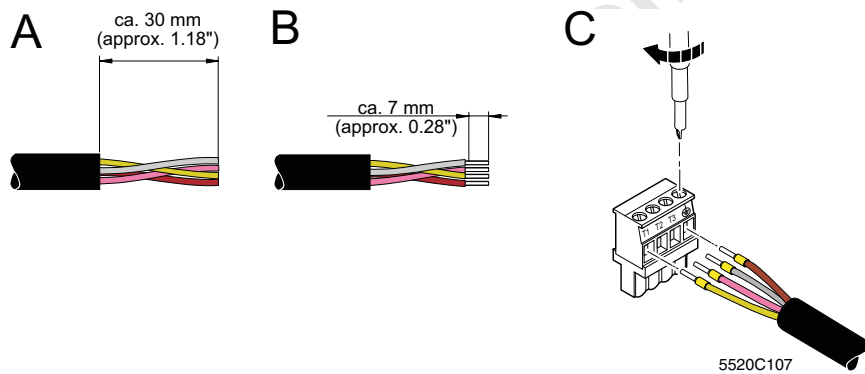

Figure 10-15 Assembling the motor circuit connector

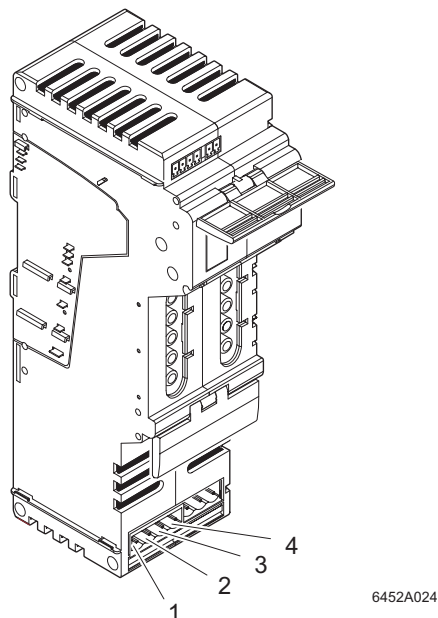
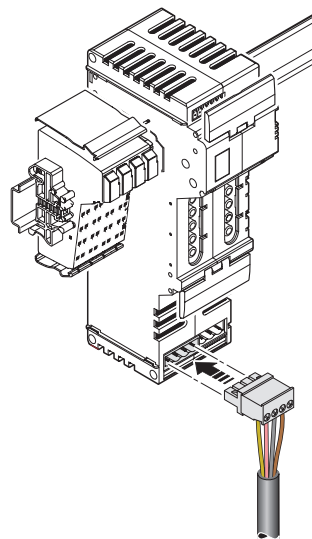

Figure 10-16 Motor output assignment

Table 10-6 Pin assignment of the motor circuit connector (HV-COMBICON)

Pin	X10 (motor)
1	Motor: T1
2	Motor: T2
3	Motor: T3
4	Motor: \ominus

Insert the assembled connector in connection X10 (Figure 10-17).



60521011

Figure 10-17 Inserting the motor circuit connector

10.5.3 Connecting the brake module and brake (optional)

The brake module can be used to control the brake on motors with a brake. It contains a passive semiconductor, which can be used for quick motor braking. The brake module is designed for motors with a nominal voltage of 400 V AC.

Assemble the connector for the brake as shown in Figure 10-18:

- Strip approximately 30 mm off the outer cable sheath (detail A).
- Strip approximately 7 mm off the wires (detail B).
- Fit the wire ends with ferrules and connect the wires to the connector (detail C).



Make sure that the brake is connected with the correct polarity, otherwise it may not operate correctly.

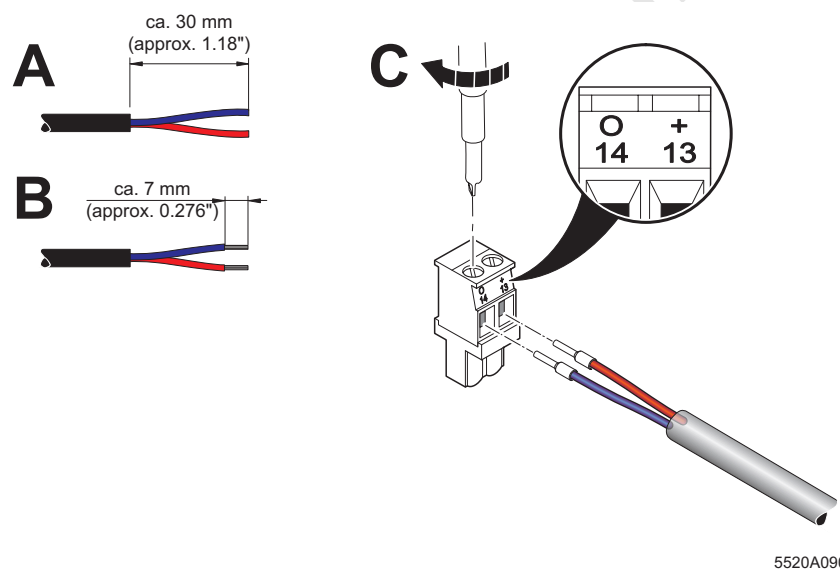

Figure 10-18 Assembling the connector for the brake

The brake module is snapped into connection X8 of a power-level terminal using a 3-pos. inverted COMBICON connector. The 2-pos. COMBICON connector for the brake is snapped into connection X9 of the brake module.

Connect the brake as shown in Figure 10-19:

- If the motor connector is plugged in, remove it. The entire module should be prepared (power-level terminal with brake module) before the I/O is connected.
- Lift up the lower release flap (detail A1).
- Snap the brake module into connection X8 (detail A2). Fasten the brake module by turning the interlocking screw (1) 90°. This secures the interlocking screw in a ventilation slot of the power-level terminal.
- Put the lower release flap down again (detail B1).
- Insert the assembled motor circuit connector into connection X10 (detail B2). (See also "Connecting the motor circuit connector" on page 10-17.)
- Insert the assembled connector for the brake into connection X9 of the brake module (detail B3).

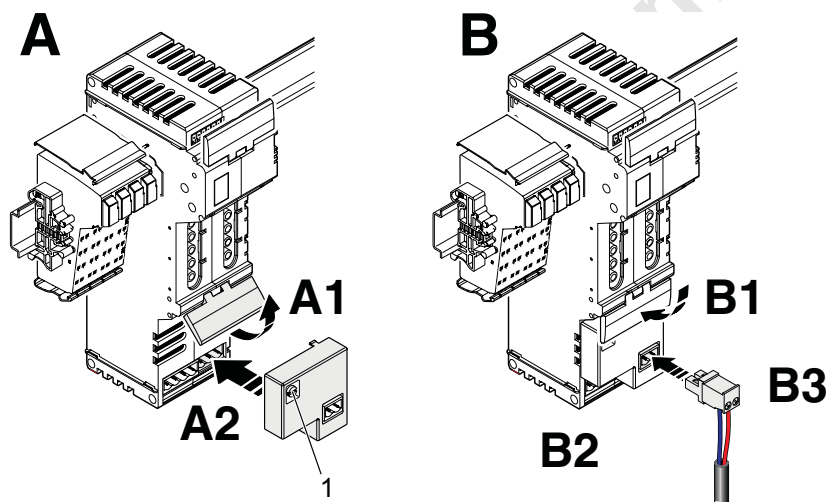

Figure 10-19 Snapping on the brake module and the connector for the brake



For additional information about the brake module, please refer to the module-specific data sheet.

10.5.4 Connecting the hand-held operator panel

Hand-held operator panel mode (manual mode) is enabled via a temporarily connected external hand-held operator panel. This panel is connected to the power-level terminal using a 4-pos. MINI-COMBICON connector. The slot is under the upper release flap (6 in Figure 10-9 on page 10-14). The hand-held operator panel can only be connected when the release flap is upright.



For the ordering data for the hand-held operator panel, please refer to the Phoenix Contact "AUTOMATION" catalog.



For additional information about hand-held operator panel mode, please refer to the data sheets for the power-level terminals.

10.5.5 Enabling the power level/24 V isolation

The MINI-COMBICON connector for terminal strip X18 (enable power level/24 V isolation) is under the upper release flap of a power-level terminal.

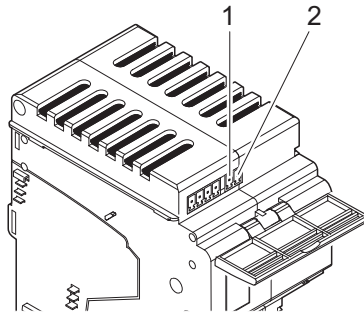

6049A022

Figure 10-20 Assignment of the enable power level/24 V isolation connection

Table 10-7 Enable power level X18 (MINI-COMBICON)

Pin	X18 (enable)
1	1 (24 V DC segment voltage U_S)
2	2 (enable power level)

The control voltage for the power level and the brake is supplied via pin 2 of the MINICOMBICON connector. The power level cannot be controlled without the 24 V control voltage.

The segment voltage U_S is used to enable the power level and can be made available using a jumper or a switch:

- 1 By default upon delivery, terminal strip X18 is supplied with a jumper inserted between pins 1 and 2.
If no switch is connected to X18, the jumper can remain inserted. The power level of the power-level terminal is enabled because the 24 V segment voltage is directly available.
- 2 If an external switch is connected between pins 1 and 2 on terminal strip X18, the power level of the power-level terminal is enabled when the switch is closed.



For additional information and safety notes, please refer to the data sheets for the power-level terminals.

IL SYS INST UM E

onlinecomponents.com

11 Inline Modular IO: Technical data and ordering data



For the system data for your bus system, please refer to the corresponding documentation.

If you are using Inline in a system with other product ranges, also observe the technical data for these product ranges. Please refer to the corresponding documentation for this technical data.



The following values are standard values for the preferred mounting position (horizontal DIN rail). For different values, please refer to the terminal-specific data sheets.

The technical data does not claim to be complete. Technical modifications reserved.

11.1 Technical data for Inline Modular IO

System data

Number of devices in an Inline station	63 devices, maximum; see documentation for bus couplers
Maximum current consumption of the Inline terminals	See terminal-specific data sheet or DB GB IB IL DEVICE LIST data sheet



When configuring an Inline station, observe the power supply through the bus couplers, power terminals, and segment terminals, as well as the current consumption of each device. This information is provided in the DB GB IB IL DEVICE LIST data sheet and in the relevant terminal-specific data sheet. It can differ depending on the individual terminal. If the maximum current carrying capacity of a potential jumper is reached, a new power terminal must be used or a new station must be created.

General data



This table provides standard data. For different values, please refer to the terminal-specific data sheets.

Instructions	Developed according to EN 50178/IEC 62103, UL 508
Ambient temperature	
Ambient temperatures (operation)	-25°C ... +55°C
Ambient temperature (storage/transport)	-25°C ... +85°C
Temperature cycles (Speed of changing from positive to negative temperatures and vice versa)	0.5 K/min (no condensation)
Permissible humidity (operation/storage/transport)	10% ... 95%, according to DIN EN 61131-2
Permissible air pressure (operation/storage/transport)	70 kPa ... 106 kPa (up to 3000 m above sea level)
Degree of protection	IP20
Class of protection	III, IEC 61140
Air and creepage distances	According to IEC 60644/IEC 60664A, DIN VDE 0110 and EN 50178/IEC 62103, DIN VDE 0160
Housing material	Plastic, PVC-free, PA6.6, self-extinguishing (V0)

IL SYS INST UM E

General data (continued)

Pollution degree according to EN 50178 2; condensation not permitted during operation

Surge voltage class II (24 V DC, 120 V AC, and 230 V AC areas)
III (400 V AC area)

Gases that may endanger functions according to DIN 40046-36, DIN 40046-37

Sulfur dioxide (SO₂) Concentration 10 ±0.3 ppm
Ambient conditions
- Temperature: 25°C (±2°C)
- Humidity: 75% (±5%)
- Test duration: 10 days

Hydrogen sulfide (H₂S) Concentration 1 ±0.3 ppm
Ambient conditions
- Temperature: 25°C (±2°C)
- Humidity: 75% (±5%)
- Test duration: 4 days

Resistance of the housing material to termites Resistant

Resistance of the housing material to fungal decay Resistant

Mechanical requirements

Vibration test 5g load, 2 hours in each direction
Sinusoidal vibrations according to (24 V DC, 120 V AC, and 230 V AC areas)
IEC 60068-2-6; EN 60068-2-6 2g load, 2 hours in each direction
(400 V AC area)

Shock test according to 25g load for 11 ms, half sinusoidal wave,
IEC 60068-2-27; EN 60068-2-27 three shocks in each direction and orientation

Broadband noise according to 0.78g load, 2.5 hours in each direction
IEC 60068-2-64; EN 60068-2-64

Conformance with EMC directive 2004/108/EC



This table provides standard data. For different values, please refer to the terminal-specific data sheets.

Noise immunity test according to EN 61000-6-2

Electrostatic discharge (ESD) EN 61000-4-2/
IEC 61000-4-2 Criterion B
6 kV contact discharge
8 kV air discharge

Electromagnetic fields EN 61000-4-3
IEC 61000-4-3 Criterion A
Field strength: 10 V/m

Fast transients (burst) EN 61000-4-4/
IEC 61000-4-4 Criterion B
Remote bus: 2 kV
Power supply: 2 kV
I/O cables: 2 kV
Criterion A
All interfaces: 1 kV

Surge voltage EN 61000-4-5/
IEC 61000-4-5 Criterion B
AC supply lines:
2.0 kV/4.0 kV (symmetrical/asymmetrical)
DC supply lines:
0.5 kV/0.5 kV (symmetrical/asymmetrical)
Signal lines:
1.0 kV/2.0 kV (symmetrical/asymmetrical)

Inline Modular IO: Technical data and ordering data

Conformance with EMC directive 2004/108/EC (continued)

Conducted interference	EN 61000-4-6 IEC 61000-4-6	Criterion A Test voltage 10 V
------------------------	-------------------------------	----------------------------------

Noise emission test according to EN 61000-6-4

Noise emission of housing	EN 55011	Class A
---------------------------	----------	---------

Data transfer in the local bus

Protocol	IEC 61158
Transmission speed	500 kbps or 2 Mbps
Transmission	Inline data jumpers

24 V bus coupler supply (U_{BK})

Nominal voltage	24 V DC
Ripple	±5%
Permissible voltage range	19.2 V DC ... 30.0 V DC, ripple included
Connection	Inline connectors



The communications power U_L (7.5 V) and the analog supply U_{ANA} (24 V) are generated from the bus coupler supply U_{BK} .

7.5 V supply of the bus logic (U_L ; generated from U_{BK})

Nominal voltage	7.5 V
Ripple	±5%
Load current	See terminal-specific data sheet or DB GB IB IL DEVICE LIST data sheet
Maximum	2 A
Terminal-specific	0.7 A (e.g., IL IB BK-PAC)



Observe the specifications in the terminal-specific data sheet for the terminal used for power supply (U_{BK}). These terminals can limit the maximum permissible load current.

Connection	Inline potential jumpers
Remark	Voltage is generated in the bus coupler by a DC/DC converter from the 24 V supply voltage. U_L is not electrically isolated from the 24 V bus coupler supply voltage. U_L is electrically isolated from the I/O voltages U_M and U_S . The communications power U_L is electronically short-circuit-proof.

Supply of terminals for analog signals (U_{ANA} ; generated from U_{BK})

Nominal voltage	24 V DC
Tolerance	-15%/+20%
Ripple	±5%
Permissible voltage range	19.2 V DC ... 30.0 V DC, ripple included

IL SYS INST UM E

Supply of terminals for analog signals (U_{ANA} ; generated from U_{BK}) (continued)

Maximum load current	500 mA
Connection	Inline potential jumpers
Remark	Decoupling of the 24 V input voltage by means of a diode. Smoothing via π filter with base frequency of 9.8 kHz and attenuation of 40 dB/decade. U_{ANA} is not electrically isolated from the 24 V bus coupler supply voltage and the 7.5 V communications power.

Supply of terminals for digital signals (U_M , U_S) in the 24 V area

Nominal voltage	24 V DC
Tolerance	-15%/+20%
Ripple	$\pm 5\%$
Permissible voltage range	19.2 V DC ... 30.0 V DC, ripple included
Load current at U_M (main supply)	See terminal-specific data sheet or DB GB IB IL DEVICE LIST data sheet
Maximum	8 A
Terminal-specific	6 A (e.g., IB IL 24 PWR IN/2-F-PAC) 4 A (e.g., IB IL 24 PWR IN/2-F-D-PAC)
Load current at U_S (segment supply)	See terminal-specific data sheet or DB GB IB IL DEVICE LIST data sheet
Maximum	8 A
Terminal-specific	6 A (e.g., IB IL 24 SEG/F-PAC) 4 A (e.g., IB IL 24 SEG/F-D-PAC) 2.5 A (e.g., IB IL 24 SEG-ELF-PAC)



Observe the specifications in the terminal-specific data sheet for the terminal used for power supply (U_M/U_S). These terminals can limit the maximum permissible load current.

Connection to corresponding terminals for supply	Inline connectors
Connection within the Inline station	Inline potential jumpers

Supply of terminals for digital signals (L) in the 120 V AC and 230 V AC areas

Nominal voltage	120 V AC 230 V AC
Tolerance	-15%/+10%
Ripple	$\pm 5\%$
Permissible voltage range	12 V AC ... 253 V AC, ripple included
Load current	8 A, maximum
Connection	Inline potential jumpers

Voltage dips and interrupts to the I/O supply

Intensity PS1	Interrupt time < 1 ms
Time interval between voltage dips	< 1 s
Behavior	Evaluation criterion 1 A dip in the supply voltage < 1 ms is not registered by the bus.

Inline Modular IO: Technical data and ordering data

Voltage dips and interrupts to the I/O supply (continued)

Intensity PS2	Interrupt time < 10 ms
Time interval between voltage dips	< 1 s
Behavior	Evaluation criterion 3 Bus disconnection, all system outputs are reset.

Current and voltage distribution in data and potential jumpers

See "Current and voltage distribution" on page 7-12.

Cable connection method/cross-section

Cable connection method for the low-level signal and low voltage levels	Spring-cage terminals
Cable connection method for the power level	Screw terminals
Cable cross-section for the low-level signal and low voltage levels (typical)	0.08 mm ² ... 1.5 mm ²
Cable cross-section for the low-level signal and low voltage levels (Connection of the protective conductor PE)	1.5 mm ² ; cable is as short as possible
Cable cross-section for the power level (Power connection, motor connection, brake connection)	0.2 mm ² ... 2.5 mm ² (stranded and solid cables)
Length of the sensor/actuator cables	
For digital terminals	< 30 m
For analog terminals	See "Maximum cable lengths for analog devices" on page A-4

Electrically isolated areas

See terminal-specific data sheets.

Air and creepage distances (according to EN 50178, VDE 0109, VDE 0110)

Isolating distance	Clearance	Creepage distance	Impulse voltage withstand level
Technology for 24 V area			
Incoming bus/bus logic	0.3 mm	0.3 mm	0.5 kV
Outgoing bus/bus logic	0.3 mm	0.3 mm	0.5 kV
Incoming bus/outgoing bus	0.3 mm	0.3 mm	0.5 kV
Bus logic/I/O	0.3 mm	0.3 mm	0.5 kV
Technology for area up to 250 V DC			
Bus logic/I/O	3.1 mm	1.1 mm	4 kV
Technology for 230 V AC area single-phase (up to 253 V AC); safe isolation according to EN 50178			
Bus logic/I/O	5.5 mm	5.5 mm	6 kV
I/O/PE	3.2 mm	3.2 mm	4 kV
Technology for 400 V AC area three-phase; safe isolation according to EN 50178			
Bus logic/400 V AC I/O	5.5 mm	3.2 mm	6 kV
24 V DC I/O/400 V AC I/O	5.5 mm	3.2 mm	6 kV
Bus logic/24 V DC I/O	0.3 mm	0.3 mm	0.5 kV
Relay outputs			
Main contact/N/O contact	See terminal-specific data sheet		
Relay contact/bus logic	See terminal-specific data sheet		

IL SYS INST UM E

Test voltages

Isolating distance

Test voltage

Technology for 24 V area (up to 60 V DC)



For information about the test voltages between the bus and other potential areas, please refer to the documentation for the bus coupler.

7.5 V communications power, 24 V bus coupler supply/functional earth ground	500 V AC, 50 Hz, 1 min.
---	-------------------------

7.5 V communications power, 24 V bus coupler supply/24 V main supply, 24 V segment supply	500 V AC, 50 Hz, 1 min.
---	-------------------------

24 V main supply, 24 V segment supply/functional earth ground	500 V AC, 50 Hz, 1 min.
---	-------------------------

Technology for area up to 250 V DC

Bus logic/I/O	2500 V AC, 50 Hz, 1 min.
---------------	--------------------------

Technology for 230 V AC area single-phase (up to 253 V AC)

Bus logic/I/O	2500 V AC, 50 Hz, 1 min.
---------------	--------------------------

Routine test	1200 V AC, 50 Hz, 1 min.
--------------	--------------------------

Relay outputs

Main contact/N/O contact	1000 V AC, 50 Hz, 1 min.
--------------------------	--------------------------

Relay contact/bus logic	2500 V AC, 50 Hz, 1 min.
-------------------------	--------------------------

11.2 Ordering data

Ordering data for Inline terminals and corresponding connectors

For the ordering data for the Inline terminals and corresponding connectors, please refer to the corresponding data sheet or the "AUTOMATION" catalog. The catalog is available in electronic form at www.eshop.phoenixcontact.com.

Ordering data for accessories

Description	Type	Order No.	Pcs./Pkt.
Power supply units	QUINT-PS ... see "INTERFACE" catalog		
Keying profile	IL CP	2742683	100
Zack marker strip to label the terminals	ZBF 6 ... see "CLIPLINE" catalog		
Zack marker strip to label the terminals	ZBF 12 ... see "CLIPLINE" catalog		
Labeling field covering one connector	IB IL FIELD 2	2727501	10
Labeling field covering four connectors	IB IL FIELD 8	2727515	10
Insert strips for IB IL FIELD 2, perforated, can be labeled using a laser printer, marker pen or CMS system (72 strips)	ESL 62X10	0809492	1
Insert strips for IB IL FIELD 8, perforated, can be labeled using a laser printer, marker pen or CMS system (15 strips)	ESL 62X46	0809502	5
DIN EN 50022 DIN rail, 2 meters	NS 35/7,5 PERFORATED NS 35/7,5 UNPERFORATED	0801733 0801681	
Standard end clamp; snapped on without tools	CLIPFIX 35-5	3022276	50
End clamp for CANopen and DeviceNet™; snapped on without tools	CLIPFIX 35	3022218	50
End clamp for use in the event of vibrations or installation on vertical DIN rail; secured with screws	E/AL-NS 35	1201662	50
Screwdriver according to DIN 5264, blade width 3.5 mm (9/64 in.)	SZF 1 - 0,6 x 3,5	1204517	1

Ordering data for documentation

Description	Type	Order No.	Pcs./Pkt.
"INTERBUS & AUTOMATION - Terms and definitions" user manual	IBS TERM RG UM E	2743695	1
"Summary of key data for Inline devices" data sheet	DB GB IB IL DEVICE LIST	-	-
"I/O modules at bus couplers" application note	AH IL BK IO LIST	-	-



The comprehensive documentation listed above and all terminal-specific documentation can be downloaded at www.download.phoenixcontact.com.
Make sure you always use the latest documentation.

IL SYS INST UM E

onlinecomponents.com

A Inline Modular IO: Additional information

A 1 Tips for working with Inline

Safe grounding

When grounding, always observe the notes in "Grounding concept" on page 9-8.

Order of the terminals

During configuration, observe the notes in "Order of the Inline Modular IO terminals" on page 9-22.

onlinecomponents.com

A 2 Configuration help for selecting the optimum analog input device for temperature recording

A 2.1 Inline Modular IO

Table A-1 Configuration help for selecting Inline Modular IO terminals for temperature recording

Criterion		IB IL TEMP 2 RTD-PAC 2861328	IB IL TEMP 4/8 RTD-PAC 2863915	IB IL TEMP 4/8 RTD/EF-PAC 2897402	IB IL TEMP 2 UTH-PAC 2861386
RTD detection	RTD detection (Inputs for resistance temperature detectors, e.g., Pt100, Pt1000, Ni100, Ni1000)	Yes	Yes	Yes	No
	Number of RTD 2-wire sensors	2	8	8	–
	Number of RTD 3-wire sensors	2	8	8	–
	Number of RTD 4-wire sensors	1	–	8	–
TC detection	TC detection (Thermocouple inputs, e.g., type B, C, E, J, K, E, R, S, T, U, W, HK)	–	–	–	Yes
	Number of TC 2-wire sensors	–	–	–	2
	Internal cold junction compensation for thermocouple detection	–	–	–	Yes
	Additional connection option for an external cold junction sensor (Pt1000, Ni1000)	–	–	–	Yes
Dynamic response	Dynamic response of measuring inputs	High	Very high	Low	High
	Measurements/second (typical for all channels)	30 ... 50	4 ... 165	0.3 ... 0.5	30
Precision	Precision	High	Medium	Very high	Medium
	Typical tolerance of Pt100 or TC (at $T_A = +25^\circ\text{C}$)	$\pm 0.26\text{ K}$	$\pm 0.50\text{ K}$	$\pm 0.09\text{ K}$	0.6 K + tolerance of cold junction (TC type K)
	Maximum tolerance of Pt100 or TC (at $T_A = +25^\circ\text{C}$)	$\pm 1.0\text{ K}$	$\pm 2.13\text{ K}$	$\pm 0.19\text{ K}$	2.4 K + tolerance of cold junction (TC type K)

Configuration help for selecting the optimum analog input device for temperature recording

A 2.2 Inline Block IO

Table A-2 Configuration help for selecting Inline Block IO modules for temperature recording

Criterion		ILB IB AI4 AO2	ILB PB AI4 AO2	ILB S3 AI4 AO2
		2878777	2878874	2692076
RTD detection	RTD detection (Inputs for resistance temperature detectors, e.g., Pt100, Pt1000, Ni100, Ni1000)	Yes	Yes	Yes
	Number of RTD 2-wire sensors	4	4	4
	Number of RTD 3-wire sensors	4	4	4
	Number of RTD 4-wire sensors	4	4	4
Dynamic response	Dynamic response of measuring inputs	Very high	Very high	Very high
	Measurements/second (typical for all channels)	43 ... 192	43 ... 192	43 ... 192
Precision	Precision	High	Medium	Medium
	Typical tolerance of Pt100 or TC (at T _A = +25°C)	±0.3 K	±0.5 K	±0.5 K
	Maximum tolerance of Pt100 or TC (at T _A = +25°C)	±1.6 K	±1.9 K	±2.0 K

A 3 Maximum cable lengths for analog devices



Please also observe the information in the device-specific data sheet.

The following applies for the section below:

- The values for the maximum cable length are valid in accordance with the installation instructions and have been determined using the following reference data for the sensor or actuator cable:

Cable type	LiYCY (TP)	
	N x 2 x 0.5	Where: N = Number of wire pairs 0.5 = Conductor cross-section A in mm ²
Inductance	0.67 mH/km (typical)	
Effective capacitance	120 nF/km	(Between the wires)



- The values in the tables also apply for versions of the specified terminal with comparable technical properties (e.g., -2MBD or non-PAC versions).
- Information about longer lengths or other cable types is available on request.

A 3.1 Analog input and temperature recording

Table A-3 Maximum cable lengths: Analog input

Criterion	IB IL AI2/SF-PAC 2861302	IB IL AI8/SF-PAC 2861412	IB IL AI8/IS-PAC 2861661	IB IL AI2/SF-230-PAC 2861577	IB IL AI4/EF-PAC 2878447
Number of channels	2	8	8	2	4
Maximum cable length	250 m	250 m	250 m	250 m	250 m

Table A-4 Maximum cable lengths: Temperature recording

Criterion	IB IL TEMP 2 RTD-PAC 2861328	IB IL TEMP 4/8 RTD-PAC 2863915	IB IL TEMP 4/8 RTD-EF-PAC 2897402
Number of channels	2	8	8
Maximum cable length	250 m ¹	250 m ¹	250 m

¹ Please observe the specified tolerances for the selected connection method (2, 3 or 4-wire) (see data sheet).

Maximum cable lengths for analog devices

A 3.2 Analog output

Table A-5 Maximum cable lengths and immunity to short-circuiting: Analog output terminals

Criterion	IB IL AO1/SF-PAC 2861315	IB IL AO1/U/SF-PAC 2861399	IB IL AO 2/U/BP-PAC 2861467	IB IL AO 2/SF-PAC 2863083	IB IL AO4/8/U/BP-PAC 2878036
Number of channels	1	1	2	2	8
Signals	0 V ... 10 V 0 mA ... 20 mA 4 mA ... 20 mA	0 V ... 10 V	-10 V ... +10 V 0 V ... 10 V	0 V ... 10 V 0 mA ... 20 mA 4 mA ... 20 mA	-10 V ... +10 V 0 V ... 10 V -5 V ... +5 V 0 V ... 5 V
Maximum cable length	250 m	250 m	500 m	250 m	250 m
Immunity to short-circuiting of analog voltage output	Yes, 1 minute	Yes, 1 minute	Yes, 1 minute	Yes, 1 minute	Yes, 1 minute
Immunity to short-circuiting of analog current output	Yes, continuous	Not present	Not present	Yes, continuous	Not present

A 3.3 Analog I/O

Table A-6 Maximum cable lengths and immunity to short-circuiting: Analog I/O

Criterion	ILB xx AI4 AO2
Number of channels for input	4
Number of channels for output	2
Signals	-10 V ... +10 V 0 V ... 10 V -5 V ... +5 V 0 V ... 5 V 0 mA ... 20 mA -20 mA ... +20 mA 4 mA ... 20 mA
Maximum cable length	250 m ¹
Immunity to short-circuiting of analog voltage output	Yes, continuous
Immunity to short-circuiting of analog current output	Yes, continuous

¹ Please observe the specified tolerances for the selected connection method (2, 3 or 4-wire) (see data sheet).

A 4 Temperature response of the terminals

Please note that derating or simultaneity limitations must be taken into consideration depending on the ambient temperature. Notes on this are provided in the terminal-specific data sheets. The terms used in the data sheets are explained below:

Power dissipation of the electronics (P_{TOT})

The power dissipation of the electronics of a terminal is calculated according to the formula provided in the terminal-specific data sheet. The calculated value must not exceed the power dissipation of the housing.

Power dissipation of the housing (P_{HOU})

The power dissipation of the housing indicates the maximum power dissipation. The maximum power dissipation is specified in the terminal-specific data sheet.

In the permissible operating temperature range, the power dissipation of the housing can be dependent on or independent of the ambient temperature.

If the power dissipation of the housing depends on the ambient temperature, a permissible working point must be defined.

Permissible working point

Depending on the power dissipation of the housing and the power dissipation of the electronics at a certain current, the maximum temperature at which the terminal can be operated with this current can be calculated.

Examples

Examples for calculating these values can be found in the section below.

A 5 Calculation examples for power dissipation and working points

A 5.1 Constant power dissipation of the housing over the operating temperature range

This calculation is illustrated using the IB IL 24 DO 8-PAC terminal as an example.

Formula to calculate the power dissipation of the electronics

This formula is terminal-specific and is provided in every data sheet.

$$P_{TOT} = 0.19 \text{ W} + \sum_{i=1}^n (0.10 \text{ W} + I_{Li}^2 \times 0.40 \Omega)$$

Where

P_{TOT}	Total power dissipation in the module
i	Index
n	Number of set outputs ($n = 1$ to 8)
I_{Li}	Load current of output i



If no output is set, the component with the sigma sign is omitted.

Example:

Load currents of the outputs:

$$I_{L1} = 0.5 \text{ A}, I_{L2} = 0.4 \text{ A}, I_{L3} = 0.2 \text{ A}, I_{L4} = 0.5 \text{ A}, I_{L5} = 0.3 \text{ A}, I_{L6} = 0.4 \text{ A}$$

Outputs 7 and 8 are not used.

Power dissipation of the electronics

According to the formula, the electronics of this specific configuration has the following power dissipation:

$$\begin{aligned} P_{TOT} = & 0.19 \text{ W} + [0.1 \text{ W} + (0.5 \text{ A})^2 \times 0.4 \Omega] \\ & + [0.1 \text{ W} + (0.4 \text{ A})^2 \times 0.4 \Omega] \\ & + [0.1 \text{ W} + (0.2 \text{ A})^2 \times 0.4 \Omega] \\ & + [0.1 \text{ W} + (0.5 \text{ A})^2 \times 0.4 \Omega] \\ & + [0.1 \text{ W} + (0.3 \text{ A})^2 \times 0.4 \Omega] \\ & + [0.1 \text{ W} + (0.4 \text{ A})^2 \times 0.4 \Omega] \end{aligned}$$

$$\begin{aligned} P_{TOT} = & 0.19 \text{ W} + 0.200 \text{ W} + 0.164 \text{ W} + 0.116 \text{ W} \\ & + 0.200 \text{ W} + 0.136 \text{ W} + 0.164 \text{ W} \end{aligned}$$

$$P_{TOT} = 1.37 \text{ W}$$

IL SYS INST UM E

Power dissipation of the housing

The value for the power dissipation of the housing is specified in every terminal-specific data sheet.

The power dissipation of the housing for the specified terminal is 2.7 W within the operating temperature range of -25°C to +55°C. The calculated power dissipation for the electronics therefore does not exceed the permissible upper limit.

Maximum load

Even with the maximum permissible load current (0.5 A per channel), the upper limit of 2.7 W is not exceeded within the permissible temperature range of -25 °C to +55 °C.

$$P_{TOT} = 0.19 \text{ W} + 8 \times [0.1 \text{ W} + (0.5 \text{ A})^2 \times 0.4 \Omega]$$

$$P_{TOT} = 1.79 \text{ W}$$

onlinecomponents.com

Calculation examples for power dissipation and working points

A 5.2 Power dissipation of the housing within the operating temperature range depending on the ambient temperature

This calculation is illustrated using the IB IL 24 DO 2-2A-PAC terminal as an example.

Formula to calculate the power dissipation of the electronics

This formula is terminal-specific and is provided in every data sheet.

$$P_{TOT} = 0.18 \text{ W} + \sum_{i=1}^n (0.20 \text{ W} + I_{Li}^2 \times 0.10 \Omega)$$

Where

P_{TOT}	Total power dissipation in the module
i	Index
n	Number of set outputs ($n = 1$ to 2)
I_{Li}	Load current of output i



If no output is set, the component with the sigma sign is omitted.

Example:

Both outputs are enabled and operating at full load. The load currents of the outputs are $I_{L1} = I_{L2} = 2 \text{ A}$.

Power dissipation of the electronics

According to the formula, the electronics of this specific configuration has the following power dissipation:

$$P_{TOT} = 0.18 \text{ W} + 2 \times [0.20 \text{ W} + (2 \text{ A})^2 \times 0.10 \Omega]$$

$$P_{TOT} = 0.18 \text{ W} + 2 \times 0.6 \text{ W}$$

$$P_{TOT} = 0.18 \text{ W} + 1.20 \text{ W}$$

$$P_{TOT} = 1.38 \text{ W}$$

Power dissipation of the housing

The value for the power dissipation of the housing is specified in every terminal-specific data sheet.

The permissible power dissipation of the housing for the IB IL 24 DO 2-2A-PAC terminal depends on the temperature.

$$P_{HOU} = 2.4 \text{ W} \quad -25^\circ\text{C} < T_A \leq -5^\circ\text{C}$$

$$P_{HOU} = 2.4 \text{ W} - [(T_A - (-5^\circ\text{C})) / 37.5^\circ\text{C/W}] \quad -5^\circ\text{C} < T_A \leq +55^\circ\text{C}$$

Where

P_{HOU}	Power dissipation of the housing
T_A	Ambient temperature

At an ambient temperature of up to -5°C , you can load the housing with the maximum power dissipation.

IL SYS INST UM E

Permissible working point At an increased ambient temperature, you must calculate the permissible working point for the calculated power dissipation.

To do this set $P_{TOT} = P_{HOU}$.

$$P_{TOT} = 2.4 \text{ W} - [(T_A + 5^\circ\text{C})/37.5^\circ\text{C/W}]$$

After changing the formula, the maximum permissible ambient temperature, with this load, is calculated as:

$$T_A = (2.4 \text{ W} - P_{TOT}) \times 37.5^\circ\text{C/W} - 5^\circ\text{C}$$

$P_{TOT} = 1.38 \text{ W}$ (from the calculation for the power dissipation of the electronics)

$$T_A = (2.4 \text{ W} - 1.38 \text{ W}) \times 37.5^\circ\text{C/W} - 5^\circ\text{C}$$

$$T_A = 1.02 \text{ W} \times 37.5^\circ\text{C/W} - 5^\circ\text{C}$$

$$T_A = 33.25^\circ\text{C}$$

With both outputs at full load, this terminal can be operated up to an ambient temperature of 33°C.

If you never operate the outputs simultaneously and if a set output consumes a current of 2 A, you can operate up to an ambient temperature of:

$$P_{TOT} = 0.18 \text{ W} + [0.20 \text{ W} + (2 \text{ A})^2 \times 0.10 \Omega]$$

$$P_{TOT} = 0.18 \text{ W} + 0.60 \text{ W}$$

$$P_{TOT} = 0.78 \text{ W}$$

$$T_A = (2.4 \text{ W} - P_{TOT}) \times 37.5^\circ\text{C/W} - 5^\circ\text{C}$$

$P_{TOT} = 0.78 \text{ W}$ (from the calculation for the power dissipation of the electronics)

$$T_A = (2.4 \text{ W} - 0.78 \text{ W}) \times 37.5^\circ\text{C/W} - 5^\circ\text{C}$$

$$T_A = 1.62 \text{ W} \times 37.5^\circ\text{C/W} - 5^\circ\text{C}$$

$$T_A = 55.75^\circ\text{C}$$

$T_A = 55^\circ\text{C}$ (maximum permissible ambient temperature)

As the maximum permissible ambient temperature is 55°C, you can operate under the conditions specified above in the entire permissible temperature range. This results in a simultaneity of 50% at 55°C as specified in the data sheet.

B Software support

B 1 Overview of the software

From the planning phase through to system servicing, our software solutions guide you through every stage of the value added chain of an automation solution.

The software tools from Phoenix Contact are perfectly designed to work together, have a modular design, and are based on international standards, which means that even complex applications can be implemented easily.

Software can be used to perform the following tasks:

- Automated planning and configuration of Inline stations:
AX SALES
- Planning, configuration, and labeling of Inline stations (terminal strips):
CLIP PROJECT
- Network and device configuration:
PC WorX, Config+, AutomationXplorer+, CMD
- Application programming:
PC WorX, programming blocks, Steeplechase VLC
- System visualization:
Visu+, AX OPC Server
- System diagnostics:
Diag+

B 2 AX SALES

The AX SALES program enables easy selection and configuration of an Inline station via a Windows user interface.

Rules for creating an Inline station and technical data for the available Inline and Fieldline products are stored in the AX SALES software. AX SALES thus provides comprehensive support during configuration, which means that the user does not have to have extensive knowledge of the product range. For example, you have the option of selecting functions according to your application. Based on this, the software creates a suggested Inline station, which meets the selected conditions and the system conditions (e.g., for maximum current carrying capacity).

**NOTE:**

Please note that software can only provide **support**. The design engineer is responsible for ensuring that the configuration is correct.

The tool offers the following functions:

- Generation of an Inline station consisting of Inline and Fieldline products
- Tool support with current monitoring and autocorrect function
 - Required additional terminals are inserted automatically (e.g., additional power terminals)
 - Terminals are positioned in the recommended order
 - Notes can be added to channels
- Immediate color visualization of the created Inline station
 - Specification of the current consumption and station width
 - Specification of Fieldline system cables and cable lengths
- Display of technical data, such as width, data width, cycle time, current consumption of the station
- Data transfer, e.g., to CLIP PROJECT, MS Word, MS Excel, programming tools
- Data transfer to the e-shop via the clipboard in order to generate orders
- Documentation options (project notes)
- Generation of price information (if a price list is loaded)
- Export and import of release lists

B 3 CLIP PROJECT



Additional information can be found in the latest "CLIPLINE" catalog or on the Internet at www.phoenixcontact.com.

The CLIP PROJECT program enables easy selection, configuration, and ordering of Phoenix Contact products and complete terminal strips via a Windows user interface. The tool offers the following functions:

- Intelligent product selection with photo support
- Configuration of terminal strips including logic tests
- Immediate color visualization of the created terminal strip
- Autocorrect function, whereby the cover, end clamp, and separating disks are positioned automatically
- Generation of parts lists, CAD drawings, and labeling data
- Data output to a printer, plotter or file
- Data output in AutoCAD.dxf format
- Data transfer to MS Excel and MS Word
- CSV interface for data exchange with another CAE system
- Management of custom databases and material numbers

B 4 Other software

The other software tools listed in "Overview of the software" on page B-1 are generally designed to configure, program, visualize, and diagnose automation products from Phoenix Contact. Therefore, they are not described in the scope of this user manual for Inline.



Additional information can be found in the latest "AUTOMATION" catalog or on the Internet at www.phoenixcontact.com.

IL SYS INST UM E

onlinecomponents.com

C Explanation of abbreviations and symbols

C 1 Explanation of abbreviations

Ground

Ground, general symbol



FE

Functional earth ground
Noiseless ground



This ground is free from external noise voltage, and is used to ground cable shields and to suppress noise and interference voltages.

Functional earth ground is a low-impedance current path between circuits and ground. It is not designed as a safety measure but rather, for example, for the improvement of noise immunity (EN 61131).

This ground connection must be separated from parts with hazardous voltage by means of double or reinforced insulation (EN 60950).

PE

Protective earth ground



This ground is used to ground devices. It also provides shock protection for people.

Protective earth ground is a low-impedance current path that minimizes the risk to the user in the event of an error (EN 61131).

GND

0 V ground; housing or chassis



In this user manual the term ground refers to common voltage return lines. Ground is electrically isolated from FE and PE. If a jumper is placed between ground and FE or PE, this isolation is removed.

Various additions to GND (such as F-GND, BC-GND, etc.) indicate separate potentials.

U_{BK}

Bus coupler supply

The voltage U_{BK} is used to supply the bus coupler power supply unit. In the power supply unit, the communications power U_L and the analog voltage U_{ANA} are generated from the voltage U_{BK}.

U_M

Main supply (I/O supply in the main circuit)

The voltage U_M supplies all of the devices connected to the main circuit.

The voltage U_M is supplied using a bus coupler or a power terminal and is led through the potential jumper to the next power terminal. (Exception: terminal with a relay output interrupts the potential jumper)

IL SYS INST UM E







U_S	<p>Segment supply (I/O supply in the segment circuit)</p> <p>The voltage U_S supplies all of the devices connected to the segment circuit.</p> <p>The voltage U_S is supplied using a bus coupler or a power terminal or is tapped from the main voltage U_M at the bus coupler, a power terminal or a segment terminal and is led through the potential jumper to the next power or segment terminal. (Exception: terminal with a relay output interrupts the potential jumper)</p>
U_{ANA}	<p>I/O supply for analog terminals</p> <p>The voltage U_{ANA} is used to supply all the terminals for analog signals.</p> <p>It is generated in the bus coupler or in a special power terminal and is led through the Inline station by means of potential routing.</p>
U_L	<p>Communications power</p> <p>The voltage U_L is used to supply all the devices with communications power (supply of the module electronics).</p> <p>It is generated in the bus coupler or in a special power terminal and is led through the Inline station by means of potential routing.</p>
P_{TOT}	Power dissipation of the electronics
P_{HOU}	Power dissipation of the housing

C 2 Representations used in basic circuit diagrams







Local bus (INTERBUS)	This designation represents the data jumpers for the local bus (two jumpers) (sometimes still called INTERBUS).
U_L	<p>This designation represents the following potential jumpers:</p> <ul style="list-style-type: none"> – Communications power (U_{L+}) – Communications power ground (U_{L-}) – Supply voltage for analog terminals (U_{ANA})
U_{ANA}	Supply voltage for analog terminals
U_S	+24 V DC segment voltage
U_M	+24 V DC main voltage
L	Phase in the 120 V AC or 230 V AC voltage area
N	Neutral conductor in the 120 V AC or 230 V AC voltage area

C 3 Frequently used symbols



Earth, ground, and equipotentials

	Ground, general symbol
	Noiseless ground, functional earth ground (FE)
	Protective earth ground (PE)
	Ground, housing (GND)
	Ground In basic circuit diagrams: Different markings indicate the electrical isolations.
	Shield In basic circuit diagrams: Different markings indicate the electrical isolations.

Inputs, outputs, and other connections

	Analog input
	Analog output
	Digital input
	Digital output
	Potential or data jumper with jumper contacts on the side
	Terminal point
	Cable(s); x indicates the number of cables

Ideal circuits

	Ideal current source
	Ideal voltage source

Resistors, capacitors, and inductors



Resistor, general symbol



Capacitor, general symbol

Semiconductors



Semiconductor diode, general symbol



LED, general symbol

In basic circuit diagram: Diagnostic and status indicators on the terminals



PNP transistor



NPN transistor (note: the general symbol for transistor (see above) is sometimes also used for NPN-wired terminals)

Miscellaneous



Protocol chip

(Bus logic including voltage conditioning)



Optocoupler



Converter, general symbol



Analog/digital converter



Digital/analog converter



Coupler with electrical isolation

Power supply unit with electrical isolation, general symbol



Coupling network



Amplifier



Electrically isolated area



Fuse

D Index

Numerics

1-wire technology	10-11
24 V isolation.....	10-21
2-wire technology.....	10-12
3-wire technology.....	10-12
4-wire technology.....	10-13

A

AC terminals	3-1
Accessory terminal.....	4-4, 4-9
Additional functional earth grounding	
Bus coupler	9-9
Power terminal	4-7, 9-8
Air and creepage distances.....	11-5
Analog circuit	7-2
Analog terminals, positioning	9-23
Application notes	1-2

B

Basic circuit diagram	
Explanation of symbols	C-2
BK IO LIST	1-2
Brake	10-19
Brake module.....	10-19
Bus connection	2-2
Bus coupler.....	4-2
Additional functional earth grounding	9-9
Diagnostic and status indicators.....	8-1
Bus systems	
IL	4-4
ILB.....	4-21

C

Cable connection method	11-5
Cable cross-section	11-5
Circuit diagram, example	7-6
Circuits.....	7-1
Connecting cables	
Shielded	10-2
Unshielded	10-1
Connecting shielded cables.....	10-2
Connecting unshielded cables	10-1

Connection method.....	10-9
1-wire technology	10-11
2-wire technology	10-12
3-wire technology	10-12
4-wire technology	10-13
Connector	
120 V AC/230 V AC internal jumpering.....	6-6
120 V AC/230 V AC special features	6-5
120 V AC/230 V AC types	6-5
24 V DC identification.....	6-4
24 V DC internal jumpering.....	6-4
24 V DC types	6-3
Colors.....	6-1
Dimensions	6-2
Special features of 120 V AC/230 V AC	
terminal points.....	6-6
Structure.....	5-1, 5-12
Terminal point	6-7
Types	6-3, 6-5
Width.....	6-1
Control box	9-2
See also Terminal box	
Control cabinet.....	9-2
Control terminal.....	4-17

D

Data formats	
IL, I/O terminals	4-12
ILB.....	4-22
Data routing	7-10, 7-12, 7-13
Data sheet.....	1-2
Data sheets.....	1-2
Data transfer	11-3
Device list	1-2
Diagnostic and status indicators	8-1
Bus coupler	8-1
I/O (ILB).....	8-10
I/O terminals	8-4
Power and segment terminals	8-3
Power-level terminals	8-7
Supply (ILB)	8-9

IL SYS INST UM E

Diagnostics		G	
Extended	8-1	GND	7-10
IL	4-12	Grounding	
ILB	4-22	Functional earth grounding	9-8
Dimensions		Grounding concept	9-8
Connector	6-2	I/O terminals	4-11
ILB	5-14	ILB	4-22
Low-level signal/low voltage	5-6	Protective earth grounding	9-8
Power housing	5-11	See also Protective earth grounding	
DIN rail	9-2, 9-3	Guideways	5-2
Documentation landscape	1-1		
E		H	
Electronic module (ILB)	5-12	Hand-held operator panel mode	10-20
Dimensions	5-14	Housing dimensions	
Structure	5-12	ILB	5-14
Electronics base (IL)	5-2	Low-level signal/low voltage	5-6
Dimensions	5-6–5-11	Power	5-11
Structure	5-1		
EMC directive	11-2	I	
Enable power level	10-21	I/O (IL)	
End clamp (IL)	9-13	Diagnostic and status indicators	8-10
End plate (IL)	9-13	I/O connection	2-2
Errors, diagnostics	8-1	I/O terminals (IL)	
ESD	9-1	Diagnostic and status indicators	8-4
EX ZONE 2	1-2	Grounding	4-11
		Protection	4-11
F		Inline	
FE	7-10	Mounting location	2-2
See also Functional earth ground/grounding		Product description	2-2
FE spring	7-10	Terminal versions	2-2
Function identification		Inline Block IO	
IL	5-5	Basic structure	5-12
ILB	5-13	Housing dimensions	5-14
Functional earth ground	9-8	Inline connector	
Functional earth grounding		Basic structure	6-1
I/O terminals	4-11	Labeling	6-7
Power terminals	4-7	Numbering	6-7
Segment terminals	4-8	Inline station	
Servo amplifier	4-14	Example	4-20
Functions		Order of the terminals	9-22
IL I/O	4-11	Installation	
ILB	4-21	Instructions	9-1
		IP20	9-2

K		Parameterization	
Keyway/featherkey connection	5-4	IL	4-12
		ILB	4-22
L		PE	7-11
Labeling	6-8	See also Protective earth ground/grounding	
Latching	5-2	Potential and data routing	5-2
Local bus transmission speed	4-2	Arrangement of jumpers	7-8
Identification	5-6	See also Data routing	
Locking clips	5-2	See also Potential routing	
Logic circuit	7-2	Potential routing	
Low voltage	3-1	Analog circuit	7-2
Low voltage terminals		Current and voltage distribution	7-12
See Low-level signal/low voltage terminals		Current carrying capacity	7-10
Low-level signal and low voltage terminals		FE	7-10, 9-8
Control terminal	4-17	FE spring	7-10
Low-level signal housing	3-5	GND	7-10
Low-level signal/low voltage terminals		Logic circuit	7-2
AC terminals	3-1	Main circuit	7-3
Accessory terminals	4-9	PE	7-11
Basic structure	5-1	Segment circuit	7-4
Housing dimensions	5-6	Power bridge	5-4, 10-16
Power terminals	4-6	Power connector	
Segment terminals	4-8	120 V AC/230 V AC	6-6
Terminals with remote bus branch	4-4	24 V DC	6-5
Voltage areas	3-1	Power-level terminals	5-4, 10-15
		Power dissipation	
M		Calculation example	A-7
Main circuit	7-3	Electronics	A-6
Mains voltage for power-level terminals	7-5	Housing	A-6
Manual mode	10-20	Working point	A-6
Mechanical requirements	11-2	Power supply	
Motor circuit connector	10-17	ILB	4-21
Mounting	2-2	Power terminal	4-4, 4-6
Distances	9-3–9-6	Additional functional earth grounding	4-7, 9-8
IL, low-level signal/low voltage	9-14	Diagnostic indicators	8-3
IL, power-level terminals	9-19	Electrical isolation	4-7
ILB	9-21	Protective earth grounding	9-10
Location	9-2	Voltage areas	4-6
Mounting position	9-2	Power-level terminal	3-1, 4-13
		Connections	4-13, 10-14
O		Positioning	9-23
Order of the Inline terminals	9-22	Protective earth grounding	9-10
		Power-level terminals	4-13
P		Basic structure	5-3
Package slips	1-3	Housing dimensions	5-11
		Programmable terminals	4-17

IL SYS INST UM E

Protection		Structure	
IL, I/O.....	4-11	Connector	5-1, 5-12
ILB.....	4-21	Electronic module (ILB)	5-12
Protective earth ground	9-10	Electronics base (IL).....	5-1
Protective earth grounding	4-7	Inline Block IO	5-12
120 V AC/230 V AC power terminal.....	9-10	Inline connector.....	6-1
I/O terminals	4-11	Low-level signal/low voltage terminals	5-1
Power-level terminals	4-13, 9-10	Power-level terminals	5-3
Q		Supply terminals	
Quick Start Guide	1-1	Accessory terminal.....	4-9
R		Power terminal	4-6
Release flaps	5-4	Segment terminal	4-8
Remote bus branch, positioning.....	9-23	Supply voltages	7-1
Removal		Bus coupler	7-1
IL, low-level signal/low voltage	9-15	System data	11-1
IL, power-level terminals.....	9-20	T	
ILB.....	9-21	Temperature response.....	A-6
Replacing a fuse	9-18	Terminal box	9-2
S		Terminal point	6-7
Safety-related segment circuit.....	1-2	Terminal point numbering	6-7
Scope of supply		Terminals for analog signals, positioning	9-23
IL	4-2	Terminals with remote bus branch	4-4
ILB.....	4-21	Test voltages	11-6
Segment circuit	4-8, 7-4	U	
Segment terminal	4-4, 4-8	User manual.....	1-1
Diagnostic indicators	8-3	V	
Functional earth grounding.....	4-8	Voltage areas.....	3-1, 4-6
Segmentation.....	4-8	IL I/O	4-12
SELV	3-1	ILB.....	4-21
Servo amplifier	4-14	W	
Connections	4-14	Working point.....	A-6
Shielding	9-11	Calculation example.....	A-7
Analog sensors and actuators	9-11		
Concept.....	9-11		
Connecting the shield.....	10-2		
IL	4-12		
ILB.....	4-22		
Shield connection clamp	10-5		
Slot.....	6-7		
Snap-on mechanism	5-2		
Status indicators			
See also Diagnostic and status indicators			