



## DT SERIES ELEMENTS WITH LEAD ATTACHMENT

### SPECIFICATIONS

- Piezoelectric film sensor
- AC Coupled
- Silver Ink Electrodes
- Protective Coating over Electrodes
- Lead Wires Attached with Rivets.

The DT Series of Piezo film sensors elements are rectangular elements of Piezo film with silver ink screen printed electrodes. They are available in a variety of different sizes and thicknesses. Lead attachment is accomplished using a riveted lug going to 12" (300 mm) of 28 AWG wire.

The DT film element produces more than 10 millivolts per micro-strain. The capacitance is proportional to the area and inversely proportional to the thickness of the element.

The DT elements are supplied with a thin protective coating over the active electrode area to prevent oxidation to the top surface of the silver ink.

### FEATURES

- Minimum Impedance: 1 MΩ
- Preferred Impedance: 10 MΩ and higher
- Output Voltage: 10 mV to 100V depending on Force and Circuit Impedance
- Storage Temperature: -40°C to +70°C [-40°F to 60°F]
- Operating Temperature: 0°C to +70°C [32°F to 160°F]

### APPLICATIONS

- Sensing Direct Contact Force
- Recording Time of an Event
- Counting Number of Impact Events
- Measuring Impact Related Events

### TYPICAL PIEZO FILM PROPERTIES

| Symbol          | Parameter                         | PVDF         | Units                                      |
|-----------------|-----------------------------------|--------------|--|
| t               | Thickness                         | 28, 52       | μm   |
| d <sub>31</sub> | Piezo Strain Constant             | 23           | (10 <sup>-12</sup> )C/N                    |
| d <sub>33</sub> |                                   | -33          |  |
| g <sub>31</sub> | Piezo Stress constant             | 216          | (10 <sup>-3</sup> )Vm/N                    |
| g <sub>33</sub> |                                   | -330         |  |
| k <sub>31</sub> | Electromechanical Coupling Factor | 12%          |  |
| k <sub>t</sub>  |                                   | 14%          |  |
| C               | Capacitance                       | 380 for 28μm | pF/cm <sup>2</sup> . @ 1KHz                |
| Y               | Young's Modulus                   | 2-4          | 10 <sup>9</sup> N/m <sup>2</sup>           |
| V <sub>0</sub>  | Speed of Sound                    | 2.2          | 10 <sup>3</sup> m/s in thickness direction |

## DT SERIES ELEMENTS WITH LEAD ATTACHMENT

### DIMENSIONS and PART NUMBERS

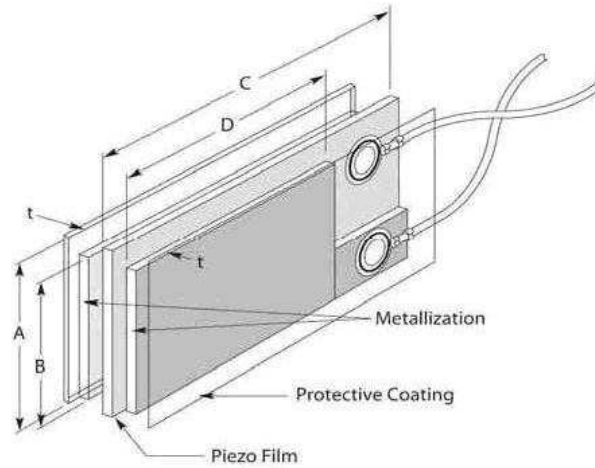

Dimensions in inches (mm)

| Model Number        | Part Number | Film Thickness | A Film   | B Electrode | C Film     | D Electrode | Total Thickness (μm) | Cap (nF) |
|---------------------|-------------|----------------|----------|-------------|------------|-------------|----------------------|----------|
| DT1-028K/L w/rivets | 1-1002908-0 | 28 μm          | .64 (16) | .484 (12)   | 1.63 (41)  | 1.19 (30)   | 40                   | 1.38     |
| DT1-052K/L w/rivets | 2-1002908-0 | 52 μm          | .64 (16) | .484 (12)   | 1.63 (41)  | 1.19 (30)   | 64                   | .740     |
| DT2-028K/L w/rivets | 1-1003744-0 | 28 μm          | .64 (16) | .484 (12)   | 2.86 (73)  | 2.42 (62)   | 40                   | 2.78     |
| DT2-052K/L w/rivets | 2-1003744-0 | 52 μm          | .64 (16) | .484 (12)   | 2.86 (73)  | 2.42 (62)   | 64                   | 1.44     |
| DT4-028K/L w/rivets | 1-1002150-0 | 28 μm          | .86 (22) | .740 (19)   | 6.72 (171) | 6.72 (171)  | 40                   | 11.00    |
| DT4-052K/L w/rivets | 2-1002150-0 | 52 μm          | .86 (22) | .740 (19)   | 6.72 (171) | 6.72 (171)  | 64                   | 5.70     |

#### NORTH AMERICA

Measurement Specialties, Inc.,  
a TE Connectivity Company  
1000 Lucas Way  
Hampton, VA 23666  
Sales and Customer Service  
Tel: +1-800-745-8008 or  
+1-757-766-1500  
Fax: +1-757-766-4297  
Technical Support  
Email: piezo@meas-spec.com

#### EUROPE

MEAS Deutschland GmbH  
a TE Connectivity Company  
Hauert 13  
44227 Dortmund  
Germany  
Sales and Customer Service  
Tel: +49 (0)231 9740 21  
Technical Support  
Tel: +49 (0)6074 862822  
Email: piezoeurope@meas-spec.com

#### ASIA

Measurement Specialties (China), Ltd.,  
a TE Connectivity Company  
F1.6-4D, Tian An Development Compound  
ShenZhen, China 518048  
Sales and Customer Service  
Tel: +86 755 8330 1004  
Technical Support  
Email: piezo@meas-spec.com

#### [TE.com/sensorsolutions](http://TE.com/sensorsolutions)

Measurement Specialties, Inc., a TE Connectivity company.

Measurement Specialties, TE Connectivity, TE Connectivity (logo) and EVERY CONNECTION COUNTS are trademarks. All other logos, products and/or company names referred to herein might be trademarks of their respective owners.

The information given herein, including drawings, illustrations and schematics which are intended for illustration purposes only, is believed to be reliable. However, TE Connectivity makes no warranties as to its accuracy or completeness and disclaims any liability in connection with its use. TE Connectivity's obligations shall only be as set forth in TE Connectivity's Standard Terms and Conditions of Sale for this product and in no case will TE Connectivity be liable for any incidental, indirect or consequential damages arising out of the sale, resale, use or misuse of the product. Users of TE Connectivity products should make their own evaluation to determine the suitability of each such product for the specific application.

© 2015 TE Connectivity Ltd. family of companies All Rights Reserved.