

## PROPER USE GUIDELINES

Cumulative Trauma Disorders can result from the prolonged use of manually powered hand tools. Hand tools are intended for occasional use and low volume applications. A wide selection of powered application equipment for extended-use, production operations is available.

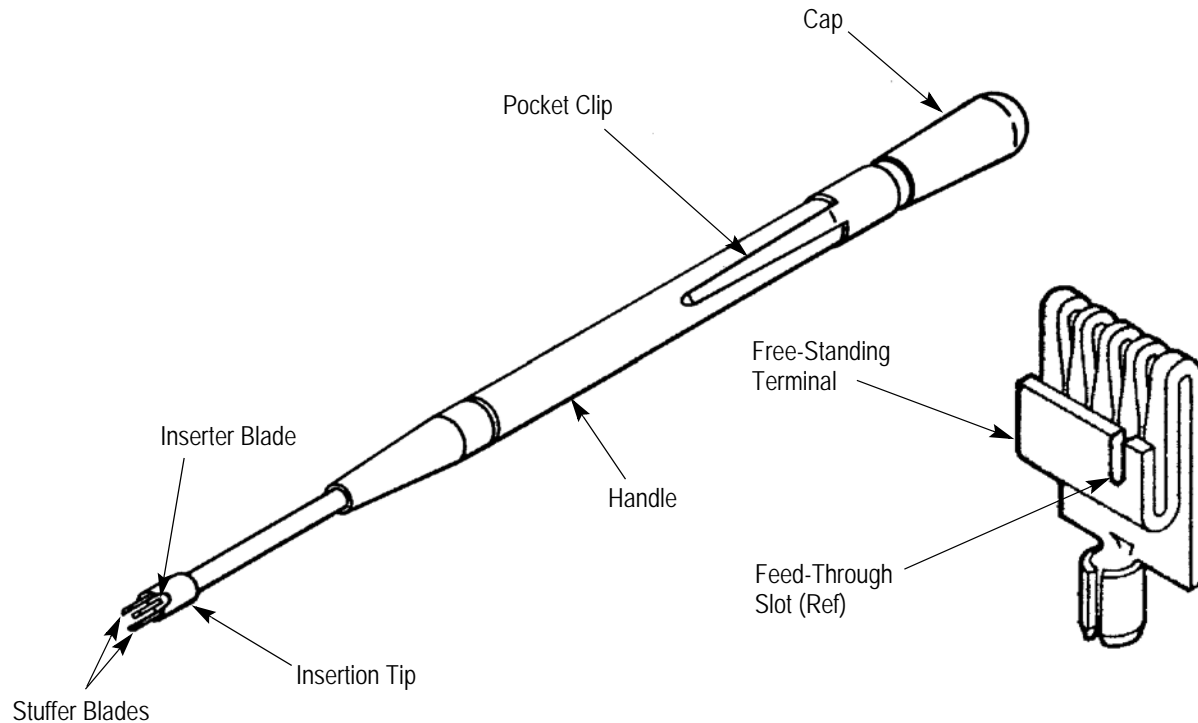
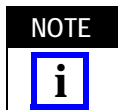

Figure 1

## 1. INTRODUCTION

This instruction sheet covers the use of CHAMP Insertion Tool 230287-1 and CHAMP Insertion/Extraction Tool 230287-3 which are impact tools designed to be used with CHAMP free-standing terminals. Tool 230287-1 is used to insert individual wires into the slots of the terminals. Tool 230287-3 can be used both for insertion and the extraction of wires. Both types of terminal will accept a wire size range of 26 to 22 with solid conductors and 24 to 22 with 7 strand conductors. The maximum insulation is 1.27 [.050] outer diameter.



*Dimensions in this instruction sheet are in metric units [with U.S. customary units in brackets]. Figures and illustrations are for identification only and are not drawn to scale.*

Read these instructions thoroughly before using the tool.

Reasons for reissue of this instruction sheet are provided in Section 6, REVISION SUMMARY.

## 2. DESCRIPTION

Tool 230287-1 features a cap, pocket clip, handle, and an insertion tip with two pin springs and one stuffer (center), as shown in Figure 1. The tool is designed to insert (terminate) wires into free-standing terminals and, when fully inserted, cut off excess wire, except when feed-through (daisy chain) applications are performed.

Tool 230287-3 has the same features as tool 230287-1; in addition, it has an extractor which is designed to remove terminated wire from the terminal slot.

## 3. INSERTION PROCEDURE

Make sure that the terminal to be terminated is firmly supported. Using either tool 230287-1 or 230287-3, proceed as follows:

1. Position the wire in the terminal wire slot with a minimum of 3.18 [.125] of wire protruding over the cutter bar. Refer to Figure 2.

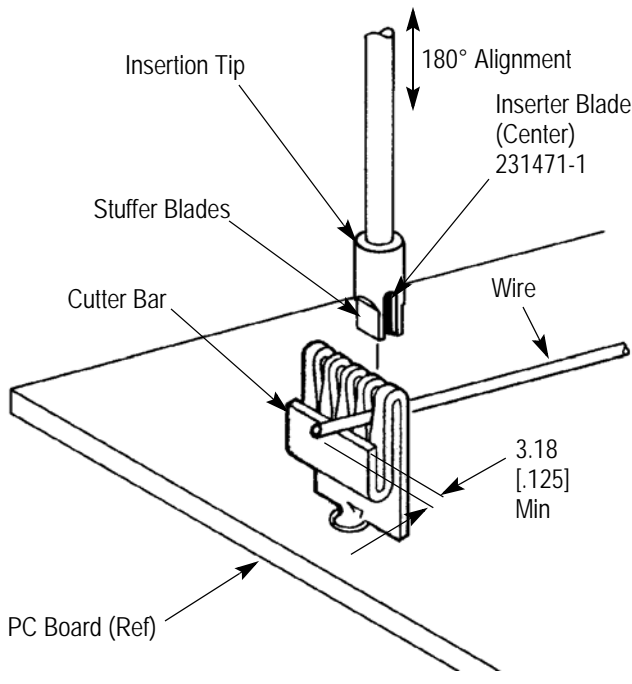

Figure 2

2. Align the insertion tip with the wire and terminal as shown in Figure 2.
3. Make sure the inserter blade (center) is aligned with the wire; then slide the insertion tip onto the terminal.
4. With the tool in 180° alignment, grip the handle firmly and push towards the terminal until the impact mechanism activates; release pressure to allow handle to retract.
5. Repeat Step 4 until the wire is below the lead-in of both wire slots, as shown in Figure 3. The wire should be properly seated after two impacts of the tool. If more are required, check the wire after each impact of the tool.

**NOTE** The wire **MUST** be cut off at the completion of a dead-end application; it will **NOT** be cut at the completion of a feed-through (daisy chain) application.

#### 4. TERMINATED WIRE REMOVAL

A terminated wire can be removed from the terminal using tool 230287-3. First, unscrew the top of the tool which covers the extractor, or remove portion of the tool. Then proceed as follows:

1. Aligning the tool so that it is perpendicular to the pc board, hook blade of extractor on wire as close as possible to terminal. See Figure 4.

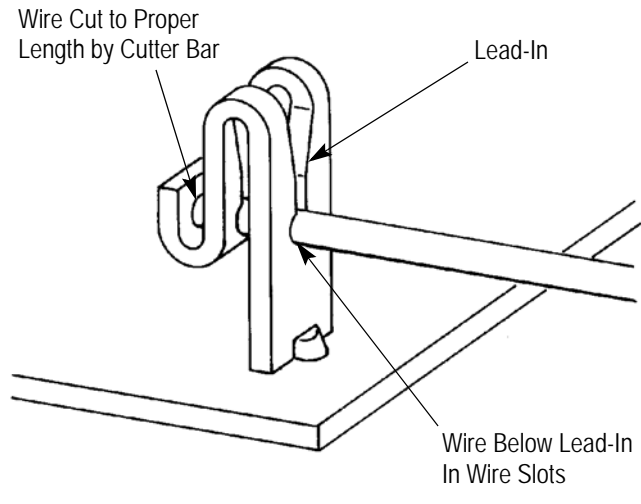

Figure 3

2. Pull extractor straight out to free wire from slot in terminal.
3. If necessary, or more convenient, hook extractor over wire between cutter bar and slot in terminal; then perform Step 2.



Care must be exercised while using the extractor because of its sharpness. Replace cover when not in use.

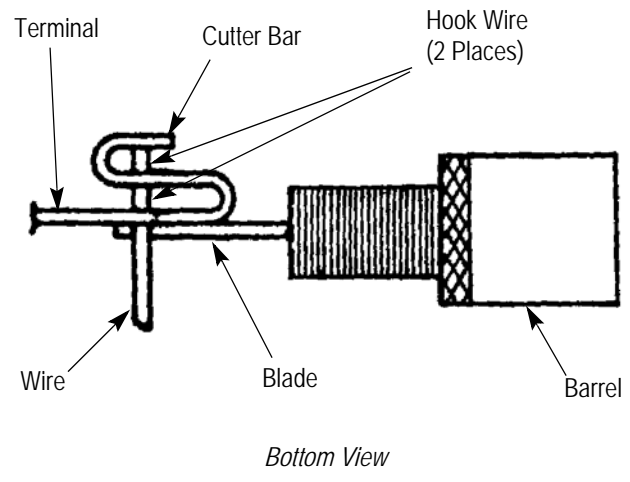
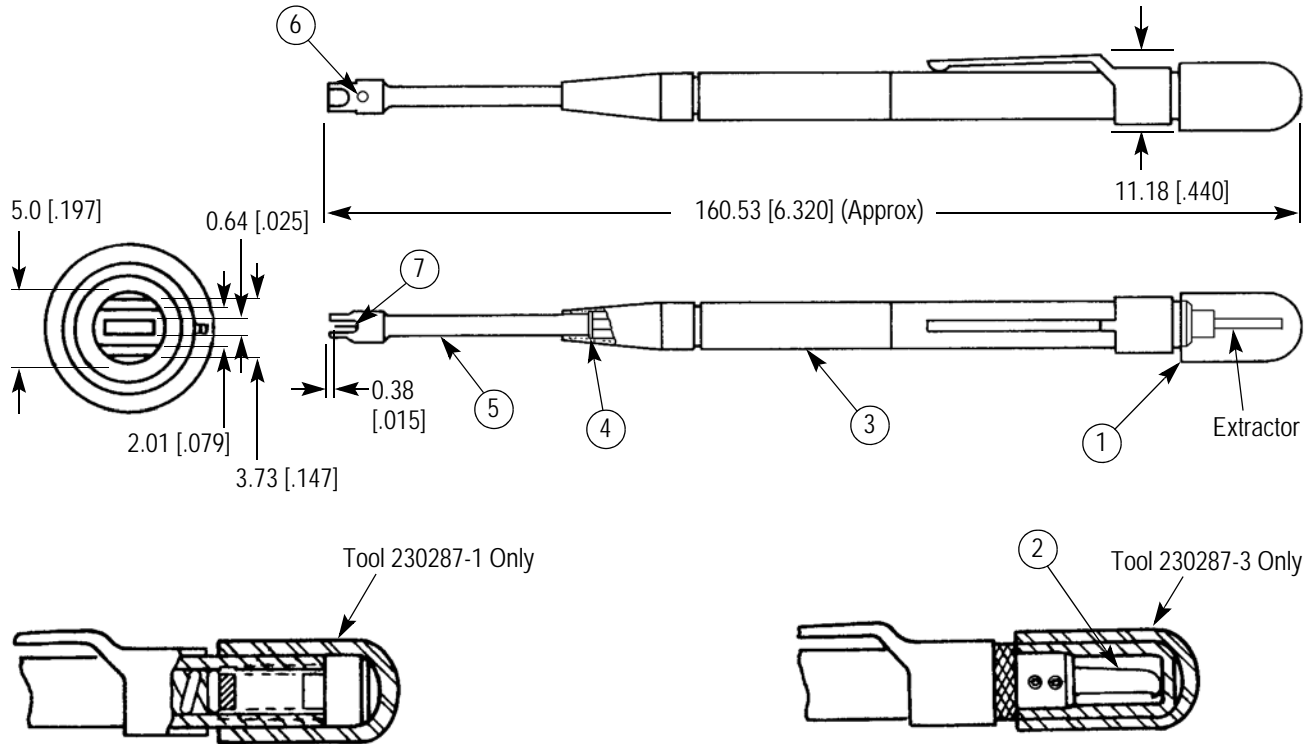

Figure 4



ITEM	PART NUMBER	DESCRIPTION	QTY PER ASSY
1	26538-2	CAP, Plastisol	1
2	231106-1	EXTRACTOR, Assembly, Hook	1
3	230300-1	BODY, Insertion, Assembly, Field	1
4	24143-2	RING, Retaining, Ext.	1
5	230298-1	INSERTER, Pin	1
6	21118-1	SPRING, Pin	1
7	231471-1	STUFFER, Tapered	1

Figure 5

**5. TOOL INSPECTION/MAINTENANCE**

Tools 230287-1 and 230287-3 should conform to the dimensions listed in Figure 5. It is recommended that the tool be inspected upon arrival at your facility to be sure it has not been damaged in transit and at regularly scheduled intervals to be sure it remains functional.

Replacement parts are listed in Figure 5. Parts other than those listed in Figure 5 should be replaced by TE Connectivity to ensure quality and reliability of the tool. Order replacement parts through your TE Connectivity representative or call 1-800-526-5142, or send a facsimile of your purchase order to 1-717-986-7605, or write to:

CUSTOMER SERVICE (038-035)  
 TYCO ELECTRONICS CORPORATION  
 PO BOX 3608  
 HARRISBURG PA 17105-3608

For tool repair service, please contact a representative at 1-800-526-5136.

**6. REVISION SUMMARY**

Since the previous release of this sheet, the following changes were made:

- Updated document to corporate requirements.