

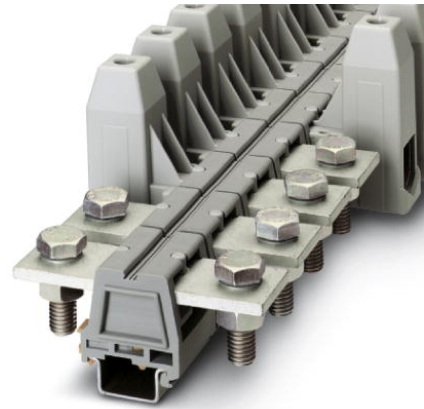

UHV150-AS/AS

Order No.: 2130033

The illustration shows a combination of versions UHV 150-AS/AS, UHV 150-KH/AS and UHV 150-KH/KH

<http://eshop.phoenixcontact.de/phoenix/treeViewClick.do?UID=2130033>Universal terminal block with bolt connection, cross section: 50 - 150 mm², width: 46 mm, color: gray

Commercial data

GTIN (EAN)	
sales group	A006
Pack	10 pcs.
Customs tariff	85369010
Catalog page information	Page 383 (CL1-2011)

Product notes

WEEE/RoHS-compliant since:
02/07/2006

<http://www.download.phoenixcontact.com>
Please note that the data given here has been taken from the online catalog. For comprehensive information and data, please refer to the user documentation. The General Terms and Conditions of Use apply to Internet downloads.

Technical data

General

Number of levels	1
Number of connections	2
Color	gray
Insulating material	PA-F
Inflammability class acc. to UL 94	HB

Dimensions

Length	110 mm
Width	46 mm
Height NS 35/15	56 mm

Technical data

Rated surge voltage	8 kV
Pollution degree	3
Surge voltage category	III
Insulating material group	II
Connection in acc. with standard	IEC 60947-7-1
Nominal current I_N	309 A
Nominal voltage U_N	1000 V

Connection data

Conductor cross section stranded min.	50 mm ²
Conductor cross section stranded max.	150 mm ²
Conductor cross section AWG/kcmil min.	2
Conductor cross section AWG/kcmil max	300 kcmil
Conductor cross section stranded, with ferrule without plastic sleeve min.	50 mm ²
Conductor cross section stranded, with ferrule without plastic sleeve max.	150 mm ²
Conductor cross section stranded, with ferrule with plastic sleeve min.	50 mm ²
Conductor cross section stranded, with ferrule with plastic sleeve max.	150 mm ²
2 conductors with same cross section, solid min.	25 mm ²
2 conductors with same cross section, solid max.	50 mm ²
2 conductors with same cross section, stranded min.	35 mm ²
2 conductors with same cross section, stranded max.	50 mm ²
2 conductors with same cross section, stranded, ferrules without plastic sleeve, min.	25 mm ²
2 conductors with same cross section, stranded, ferrules without plastic sleeve, max.	50 mm ²
Connection method	Special and hybrid connection
Stripping length	34 mm

Bolt diameter	12 mm
Tightening torque, min	25 Nm
Tightening torque max	30 Nm
Busbar	35 mm x 5 mm

Certificates / Approvals



Certification

CSA, GOST, PRS, RS, UL

Accessories

Item	Designation	Description
Assembly		
1201659	E/AL-NS 32	End clamp, for end support of UKH 50 - UKH 240, is pushed onto DIN rail NS 32 and fixed with 2 screws, width: 10 mm, color: Aluminum
1201662	E/AL-NS 35	End clamp, for end support of UKH 50 to UKH 240, is pushed onto DIN rail NS 35 and fixed with 2 screws, width: 10 mm, color: aluminum
1201028	NS 32 AL UNPERF 2000MM	G rail 32 mm (NS 32)
1201280	NS 32 CU/120QMM UNPERF 2000MM	G-profile DIN rail, deep-drawn, material: Copper, unperforated, height 15 mm, width 32 mm, length 2 m
1201358	NS 32 CU/35QMM UNPERF 2000MM	G-profile DIN rail, material: Copper, unperforated, height 15 mm, width 32 mm, length 2 m
1201002	NS 32 PERF 2000MM	G-profile DIN rail, material: Steel, perforated, height 15 mm, width 32 mm, length 2 m
1201015	NS 32 UNPERF 2000MM	G-profile DIN rail, material: Steel, unperforated, height 15 mm, width 32 mm, length 2 m
0801762	NS 35/ 7,5 CU UNPERF 2000MM	DIN rail, material: Copper, unperforated, height 7.5 mm, width 35 mm, length: 2 m
0801733	NS 35/ 7,5 PERF 2000MM	DIN rail, material: Steel, galvanized and passivated with a thick layer, perforated, height 7.5 mm, width 35 mm, length: 2 m
0801681	NS 35/ 7,5 UNPERF 2000MM	DIN rail, material: Steel, unperforated, height 7.5 mm, width 35 mm, length: 2 m
1201756	NS 35/15 AL UNPERF 2000MM	DIN rail, deep-drawn, high profile, unperforated, 1.5 mm thick, material: Aluminum, height 15 mm, width 35 mm, length 2 m

1201895	NS 35/15 CU UNPERF 2000MM	DIN rail, material: Copper, unperforated, 1.5 mm thick, height 15 mm, width 35 mm, length: 2 m
1201730	NS 35/15 PERF 2000MM	DIN rail, material: Steel, perforated, height 15 mm, width 35 mm, length: 2 m
1201714	NS 35/15 UNPERF 2000MM	DIN rail, material: Steel, unperforated, height 15 mm, width 35 mm, length: 2 m
1201798	NS 35/15-2,3 UNPERF 2000MM	DIN rail, material: Steel, unperforated, 2.3 mm thick, height 15 mm, width 35 mm, length: 2 m
2130428	UHV -E	End clamp, Width: 5.2 mm, Color: gray
2130415	UHV -TP2	Separating plate, Width: 2 mm, Height: 67.5 mm, Color: gray
2130460	UHV150-AH	Covering hood, Color: gray
2130651	UHV150-VS 2	Connection rail, Color: silver
2130664	UHV150-VS 3	Connection rail, Color: silver

Marking

1007248	SBS10:UNBEDRUCKT	Marker cards, unprinted, for individual labeling with the M-PEN, 250-section, perforated, white plastic
1050525	ZB10:SO/CMS	Zack strip, 10-section, divisible, special printing, marking according to customer requirements

Plug/Adapter

3009244	UKH 150/240 EP	Insertion profile
---------	----------------	-------------------

Tools

1201947	VDE-ISS 8	Allen wrench, fully insulated, safety tool in accordance with EN 60900, length: 150 mm, handle width: 110 mm, for all terminal blocks with 10 mm Allen screw
---------	-----------	--

Diagrams/Drawings

Dimensioned drawing

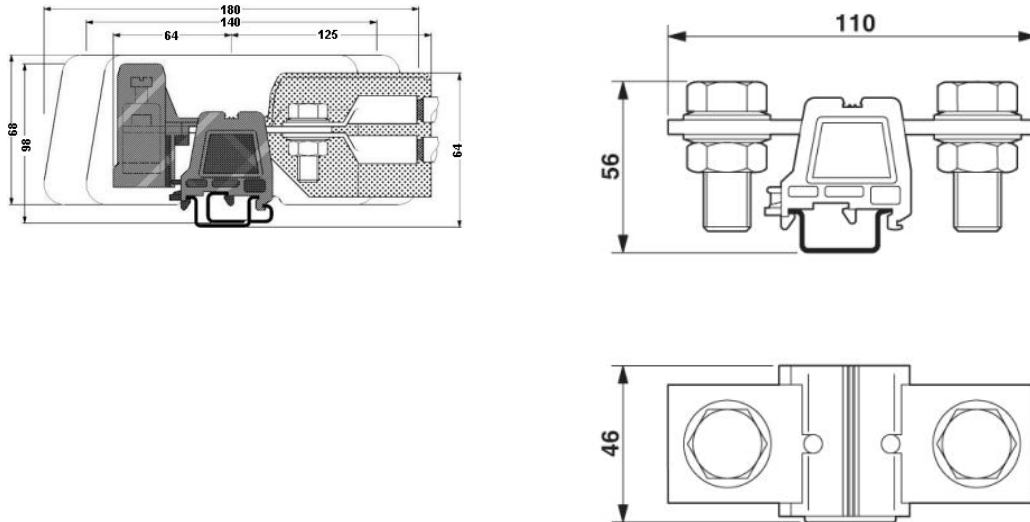

Circuit diagram

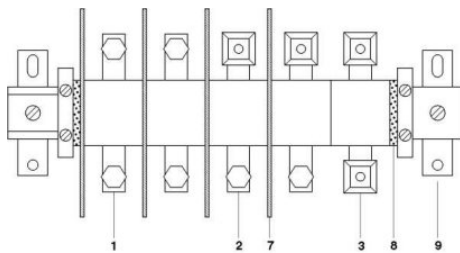

- 1 = high current connector, AS screw set on both sides
- 2 = high current connector, terminal sleeve KH on one side, screw set AS on the other side
- 3 = high current connector, terminal sleeves KH on both sides, for direct cable connection
- 7 = separating plate
- 8 = end piece
- 9 = flat bracket

Address

PHOENIX CONTACT Inc., USA
586 Fulling Mill Road
Middletown, PA 17057, USA
Phone (800) 888-7388
Fax (717) 944-1625
<http://www.phoenixcon.com>



© 2011 Phoenix Contact
Technical modifications reserved;