

LOC	DIST	REVISIONS					
GP	00	P	LTN	DESCRIPTION	DATE	DWN	APVD
		A		INITIAL RELEASE	25MAY2012	LW	AC
		A1		REV PER ECR-12-010636	19JUN2012	LW	AC
		A2		REV PER ECR-13-000356	09JAN2013	LW	AC

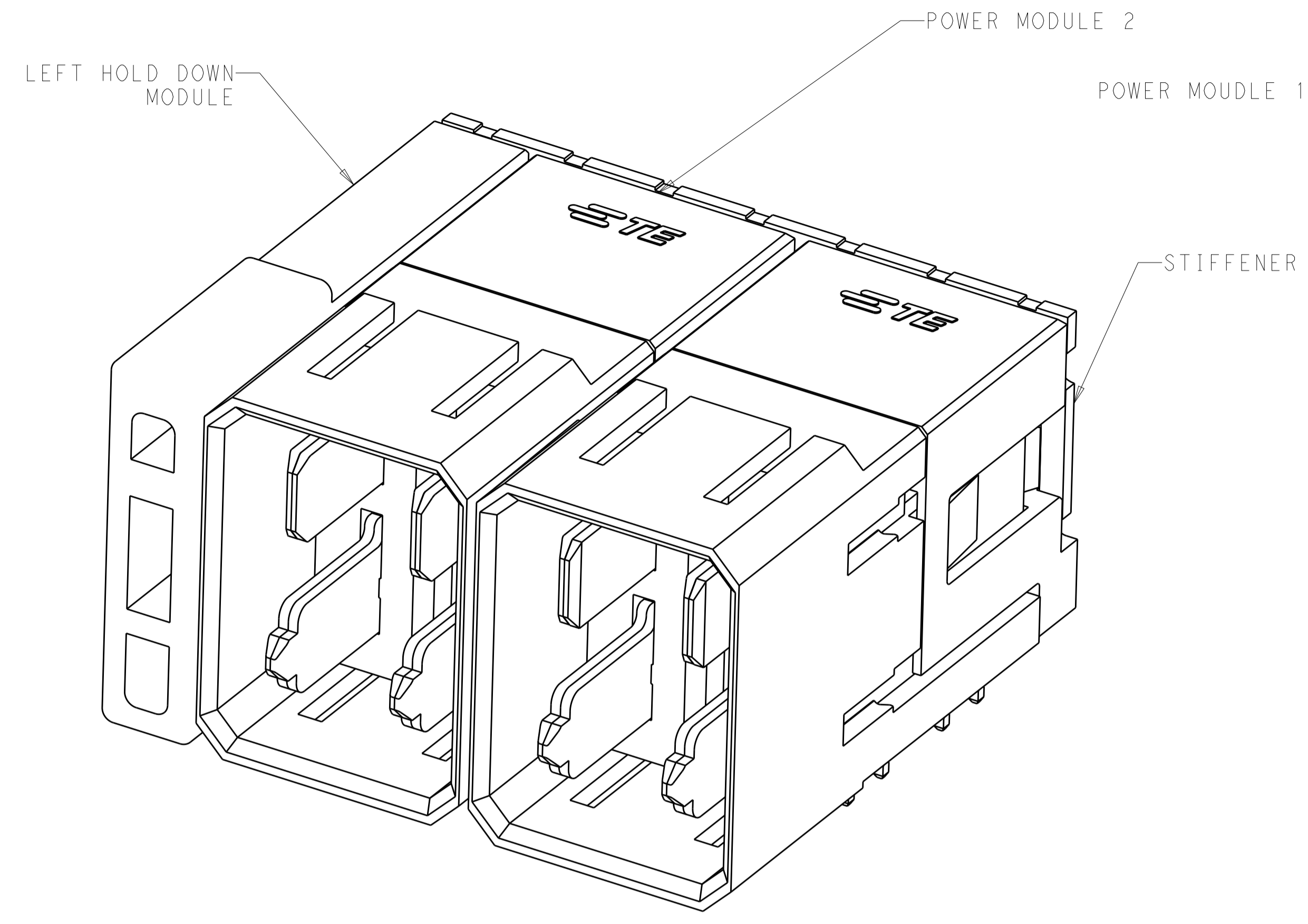

HEADER WITH LEFT HOLD DOWN MODULE

- NOTES:
- △ MATERIALS:
 HOUSING: HIGH TEMP. THERMOPLASTIC GLASS/MINERAL FILLED UL94V-0
 TERMINAL: COPPER ALLOY
 - △ FINISH:
 TIN OPTION-0.76um MIN GOLD AT CONTACT AREA AND
 1.27um MIN NICKEL UNDERPLATED OVER ALL
 2.54um TIN AT SOLDER TAIL AREA
 TIN-LEAD OPTION-0.76um MIN GOLD AT CONTACT AREA AND
 1.27um MIN NICKEL UNDERPLATED OVER ALL
 2.54um TIN-LEAD AT SOLDER TAIL AREA
 - △ REFER TO TE'S PRODUCT SPECIFICATION: 108-2473
 FOR PLATED THROUGH-HOLE SPECIFICATION AND TORQUE FORCE
 - 4 CONNECTOR WERE PACKED BY TRAY
 REFER TO TE'S PACKAGING SPECIFICATION: 107-97873
 - 5 MATED WITH *-2169806-* OR *-2169853-*
 - △ LASER MARK PART NUMBER AND DATE CODE (YYWWDS)
 CAN BE AT THE OPPOSITE SIDE
 - △ ADD 11.40MM FOR EACH ADDITIONAL MODULE
 - 8. REFER TO DOCUMENT NUMBER: 2169802 FOR INDIVIDUAL
 MODULE COMPONENT INFORMATION
 - △ FIRST POWER MODULE(1#) STARTS FROM THE RIGHT
 - △ DIMENSION P1&P2 FOR POWER MODULE 1, P3&P4 FOR POWER MODULE 2
 - △ COMPONENT STAY AWAY ZONE FROM CONNECTOR
 - △ ALL PARTS ARE SHIPPED WITH A 2-32 AB TYPE SELF-TAPPING
 SCREW P/N: 2057509-2

STATUS	PACKAGING	PLATING TYP	P4	P3	P2	P1	DIM A	NUMBER OF POWER MODULE	PART NUMBER
OBSOLETE			6.90	5.70	6.90	5.70	26.40	2X	7-2180850-0
OBSOLETE			6.90	5.70	5.70	6.90	26.40	2X	6-2180850-9
OBSOLETE			6.90	5.70	5.70	5.70	26.40	2X	6-2180850-8
OBSOLETE			6.90	5.70	6.90	6.90	26.40	2X	6-2180850-7
OBSOLETE			5.70	6.90	6.90	5.70	26.40	2X	6-2180850-6
OBSOLETE			5.70	6.90	5.70	6.90	26.40	2X	6-2180850-5
OBSOLETE			5.70	6.90	5.70	5.70	26.40	2X	6-2180850-4
OBSOLETE			5.70	6.90	6.90	6.90	26.40	2X	6-2180850-3
OBSOLETE			5.70	5.70	6.90	5.70	26.40	2X	6-2180850-2
OBSOLETE	TRAY	TIN-LEAD	5.70	5.70	5.70	6.90	26.40	2X	6-2180850-1
OBSOLETE			5.70	5.70	5.70	5.70	26.40	2X	6-2180850-0
OBSOLETE			5.70	5.70	6.90	6.90	26.40	2X	5-2180850-9
OBSOLETE			6.90	6.90	6.90	5.70	26.40	2X	5-2180850-8
OBSOLETE			6.90	6.90	5.70	6.90	26.40	2X	5-2180850-7
OBSOLETE			6.90	6.90	5.70	5.70	26.40	2X	5-2180850-6
OBSOLETE			6.90	6.90	6.90	6.90	26.40	2X	5-2180850-5
OBSOLETE			N/A	N/A	6.90	5.70	15.00	1X	5-2180850-4
OBSOLETE			N/A	N/A	5.70	6.90	15.00	1X	5-2180850-3
OBSOLETE			N/A	N/A	5.70	5.70	15.00	1X	5-2180850-2
OBSOLETE			N/A	N/A	6.90	6.90	15.00	1X	5-2180850-1
ACTIVE			6.90	5.70	6.90	5.70	26.40	2X	2-2180850-0
ACTIVE			6.90	5.70	5.70	6.90	26.40	2X	1-2180850-9
ACTIVE			6.90	5.70	5.70	5.70	26.40	2X	1-2180850-8
ACTIVE			6.90	5.70	6.90	6.90	26.40	2X	1-2180850-7
ACTIVE			5.70	6.90	6.90	5.70	26.40	2X	1-2180850-6
ACTIVE			5.70	6.90	5.70	6.90	26.40	2X	1-2180850-5
ACTIVE			5.70	6.90	5.70	5.70	26.40	2X	1-2180850-4
ACTIVE			5.70	6.90	6.90	6.90	26.40	2X	1-2180850-3
ACTIVE			5.70	5.70	6.90	5.70	26.40	2X	1-2180850-2
ACTIVE			5.70	5.70	5.70	6.90	26.40	2X	1-2180850-1
ACTIVE			5.70	5.70	5.70	5.70	26.40	2X	1-2180850-0
ACTIVE			5.70	5.70	6.90	6.90	26.40	2X	2180850-9
ACTIVE			6.90	6.90	6.90	5.70	26.40	2X	2180850-8
ACTIVE			6.90	6.90	5.70	6.90	26.40	2X	2180850-7
ACTIVE			6.90	6.90	5.70	5.70	26.40	2X	2180850-6
ACTIVE			6.90	6.90	6.90	6.90	26.40	2X	2180850-5
ACTIVE			N/A	N/A	6.90	5.70	15.00	1X	2180850-4
ACTIVE			N/A	N/A	5.70	6.90	15.00	1X	2180850-3
ACTIVE			N/A	N/A	5.70	5.70	15.00	1X	2180850-2
ACTIVE			N/A	N/A	6.90	6.90	15.00	1X	2180850-1

THIS DRAWING IS A CONTROLLED DOCUMENT. DWN: LERRY WANG 13FEB2012
 CHK: SUNY ZHAO 13FEB2012
 APVD: SUNY ZHAO 13FEB2012

STE TE Connectivity

PRODUCT APEC
 APPLICATION SPEC
 114-32028

NAME: IMPACT POWER 3 PAIR R/A HEADER W/HOLD DOWN LEFT PRESS FIT

SIZE: A1 CAGE CODE: 2180850 DRAWING NO: 100779

RESTRICTED TO: -

CUSTOMER DRAWING SCALE: 4:1 SHEET 1 OF 3 REV: A2

LOC	DIST	REV	DATE	BY	APPV
GP	00				
REVISIONS			DESCRIPTION	DATE	BY
			SEE SHEET 1		

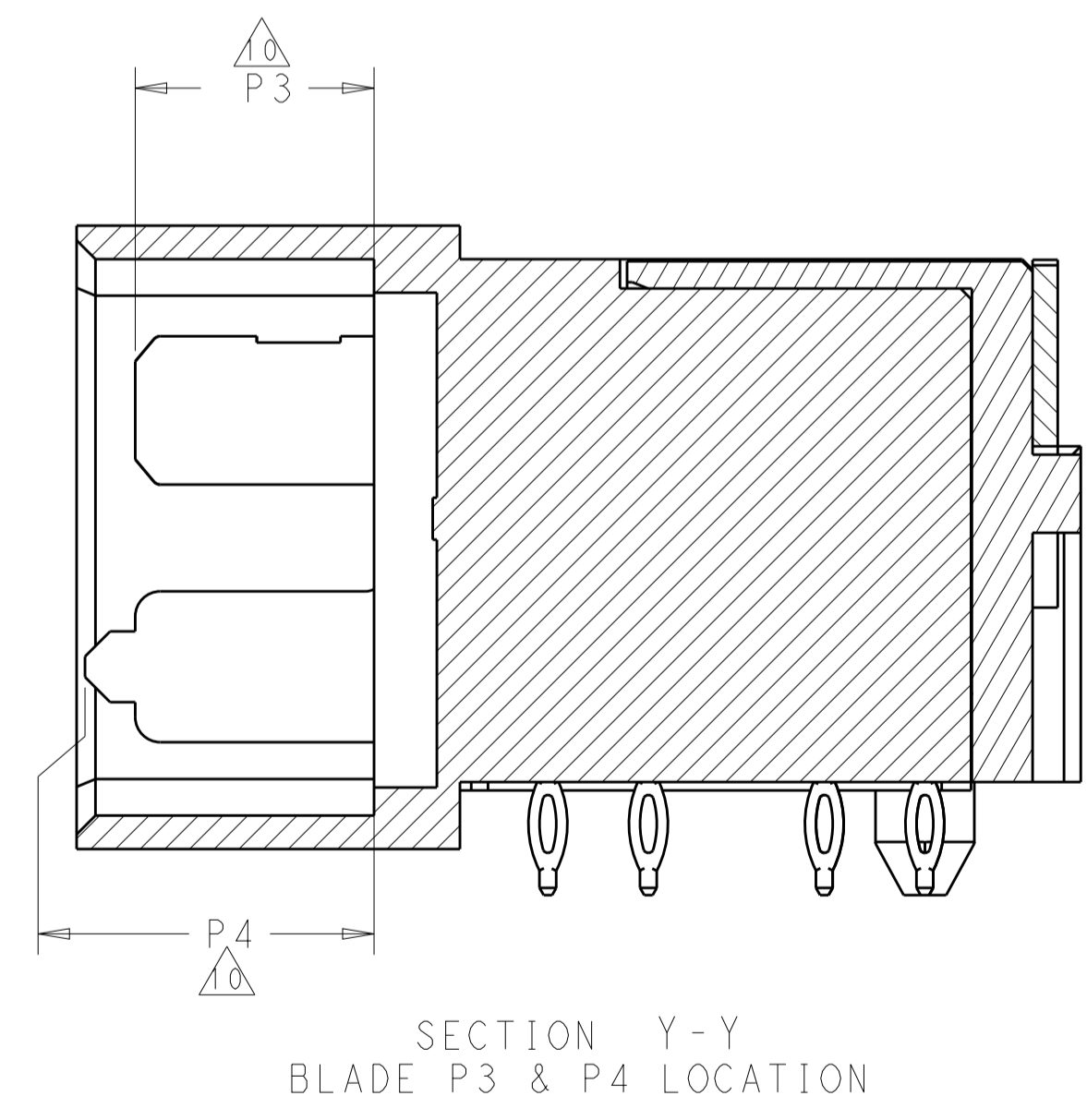
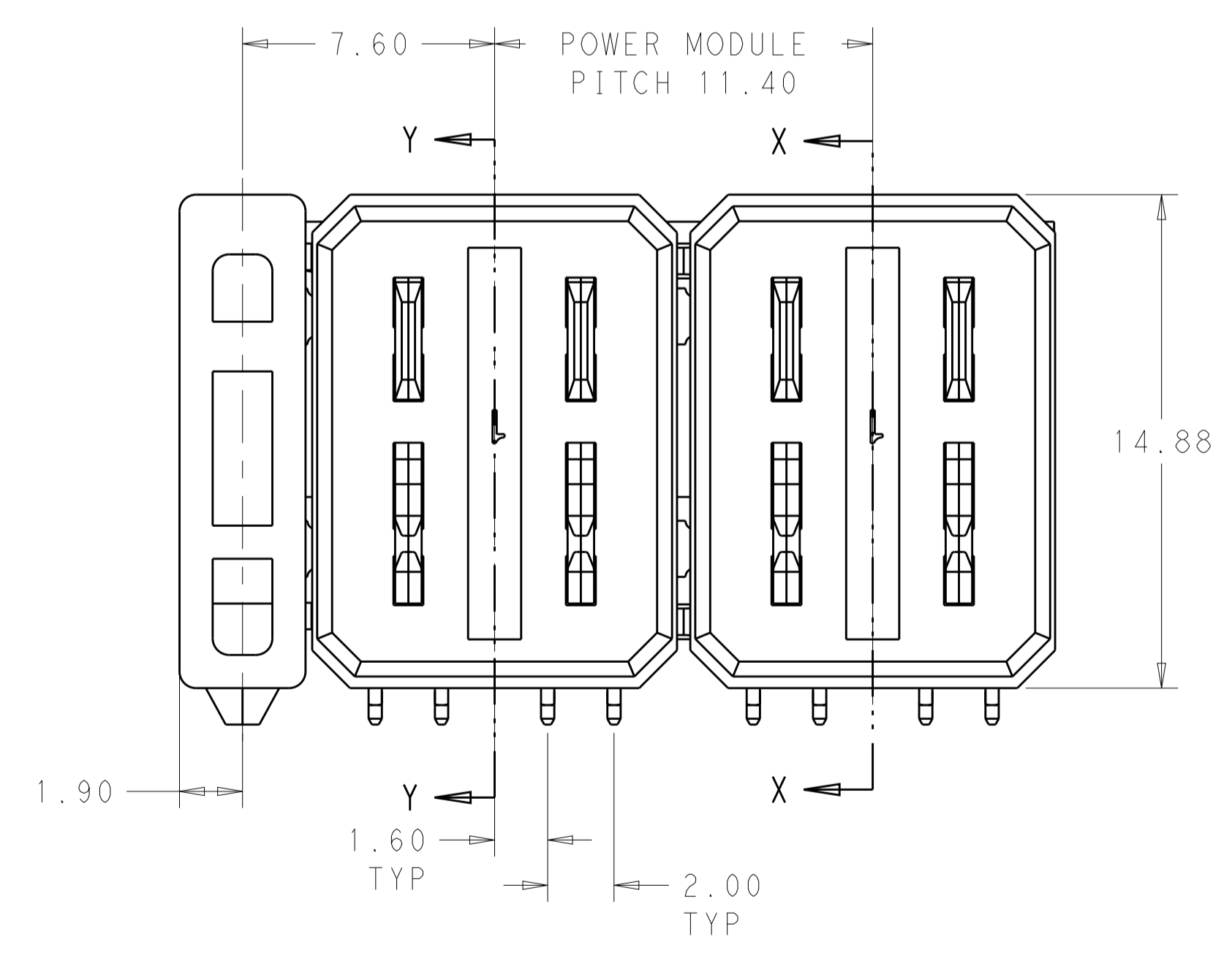
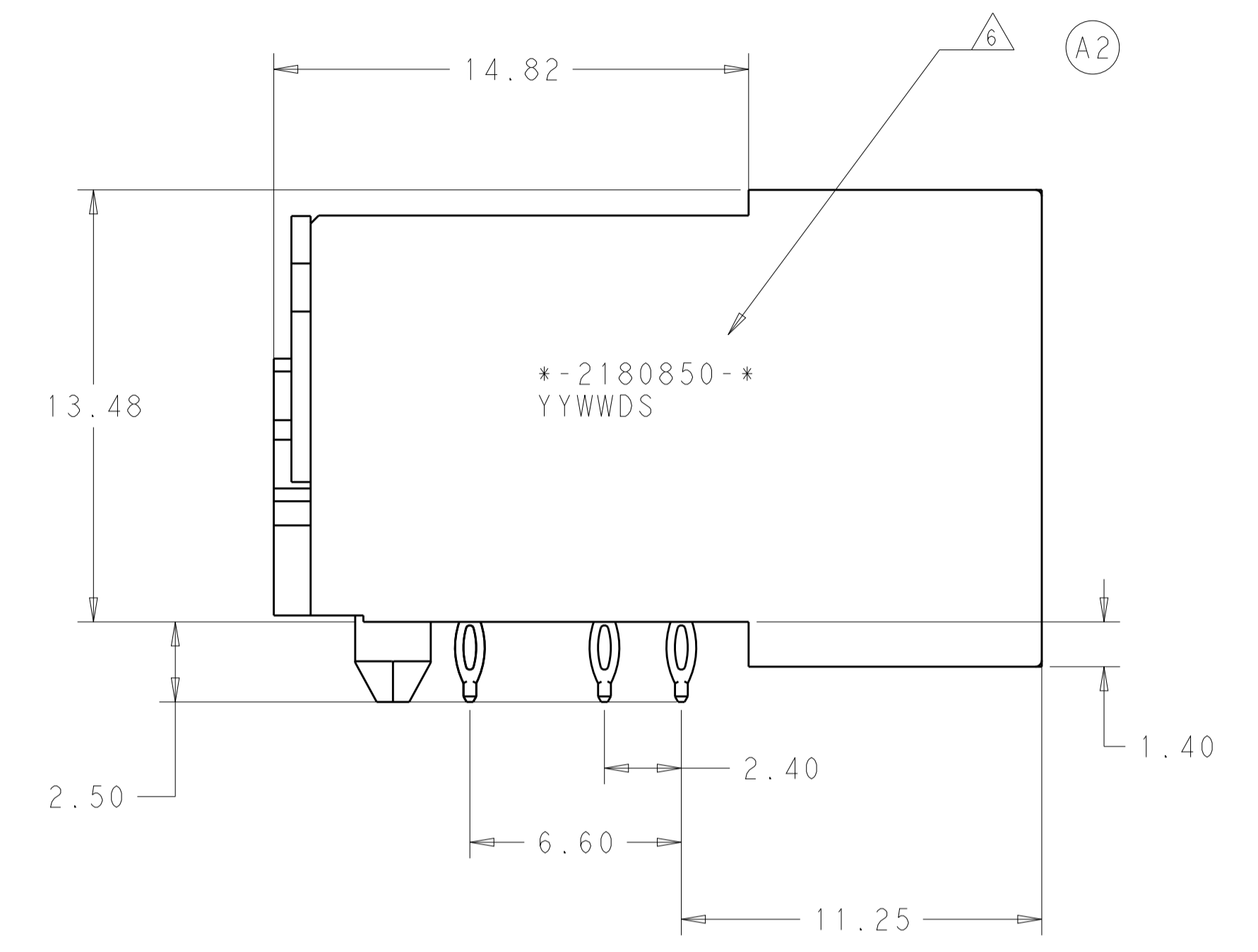
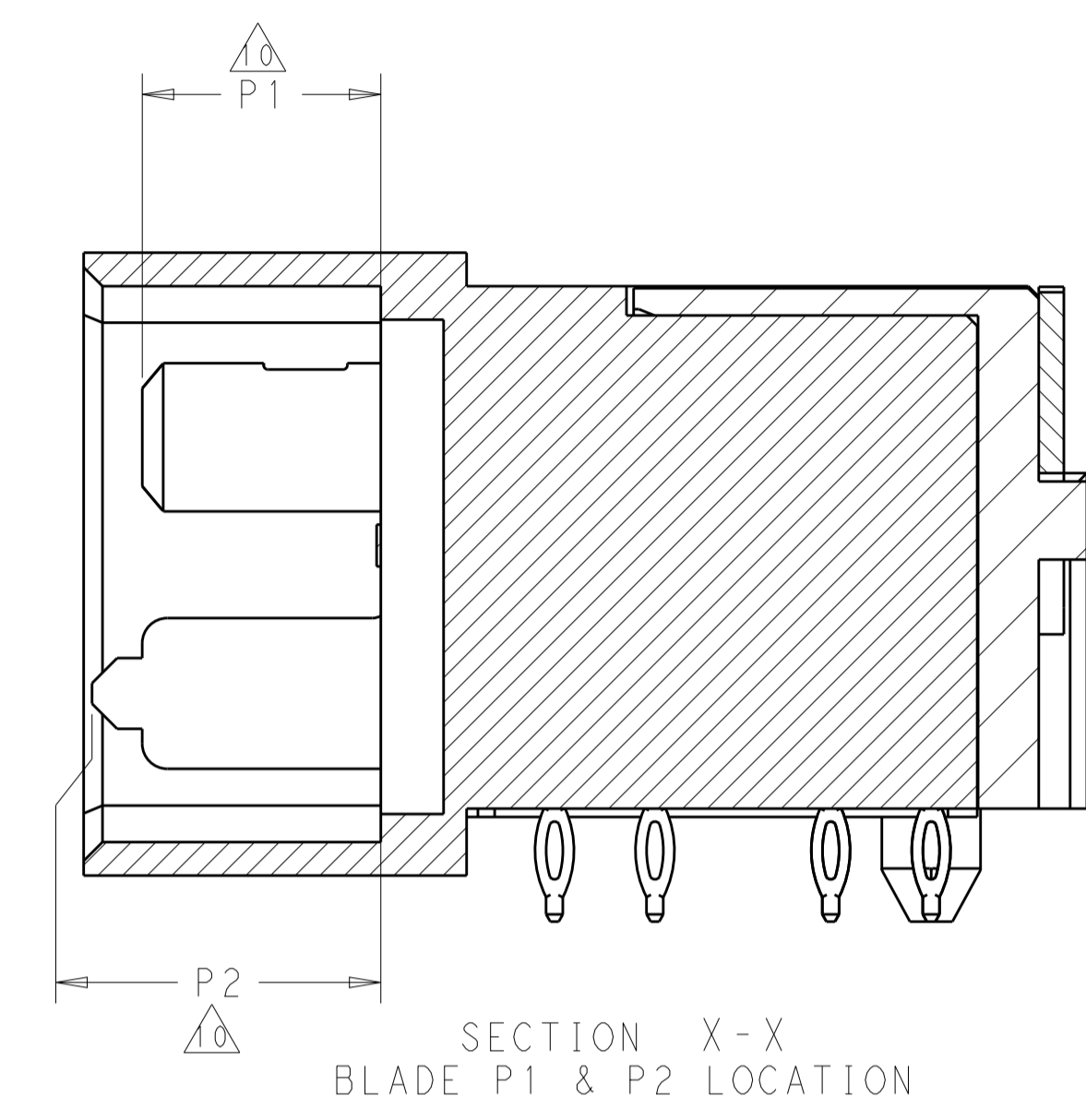
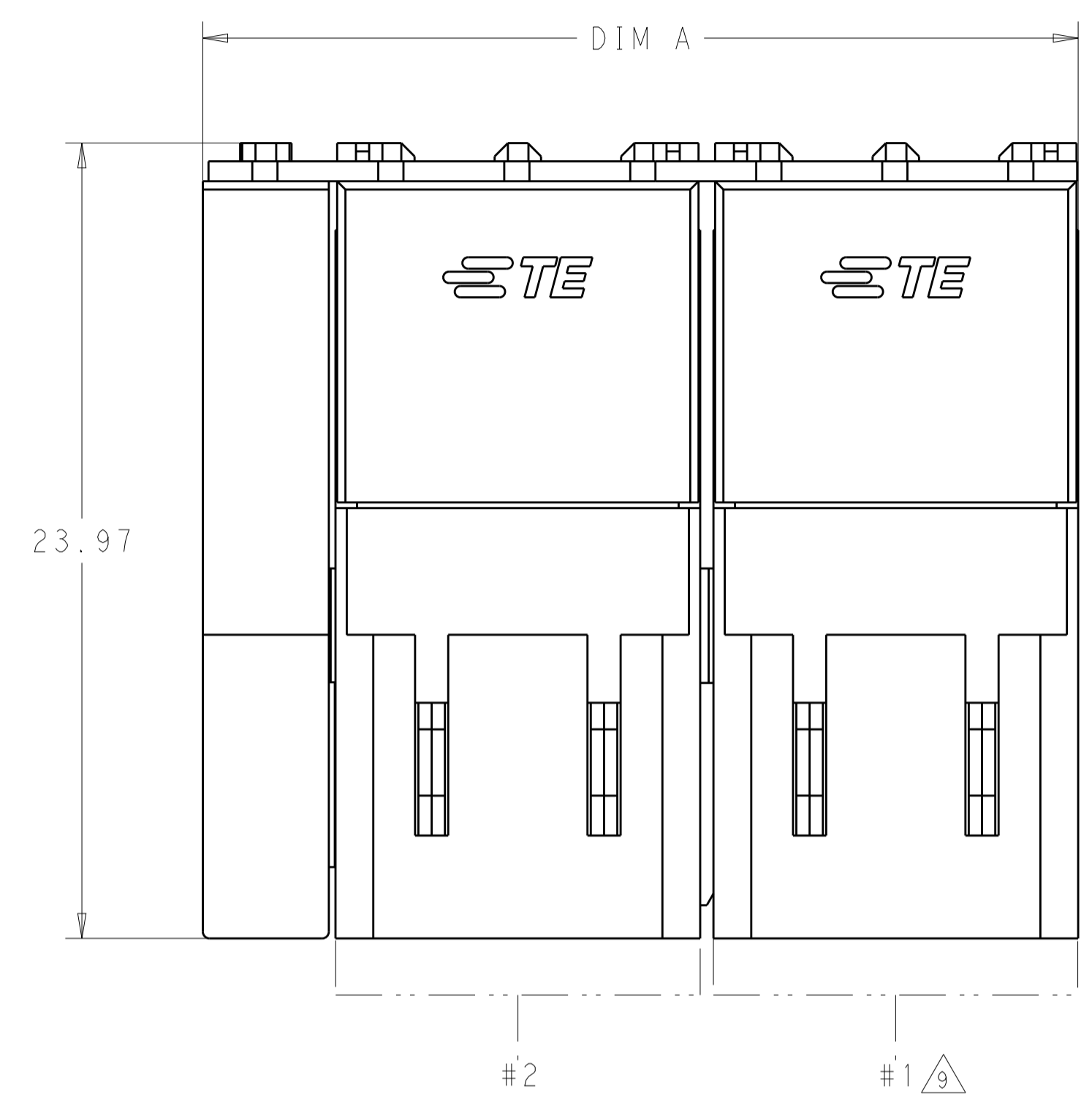

THIS DRAWING IS A CONTROLLED DOCUMENT.		OWN: LERRY WANG 13FEB2012	TE Connectivity
DIMENSIONS: mm		CHK: SUNY ZHAO 13FEB2012	
TOLERANCES UNLESS OTHERWISE SPECIFIED:		APVD: SUNY ZHAO 13FEB2012	NAME: IMPACT POWER 3 PAIR R/A HEADER W/HOLD DOWN LEFT PRESS FIT
0 PLC ±.2	1 PLC ±.25	PRODUCT SPEC	SIZE: A1
2 PLC ±.25	3 PLC ±.25	APPLICATION SPEC	CAGE CODE: C=2180850
4 PLC ±.25	ANGLES ±.5°	114-32028	RESTRICTED TO:
MATERIAL:	FINISH:	WEIGHT:	SCALE: 4:1
CUSTOMER DRAWING		100779	SHEET 2 OF 3
			REV A2

LOC		DIST		REVISIONS			
GP	00	P	LTN	DESCRIPTION	DATE	OWN	APVD
		-		SEE SHEET 1			

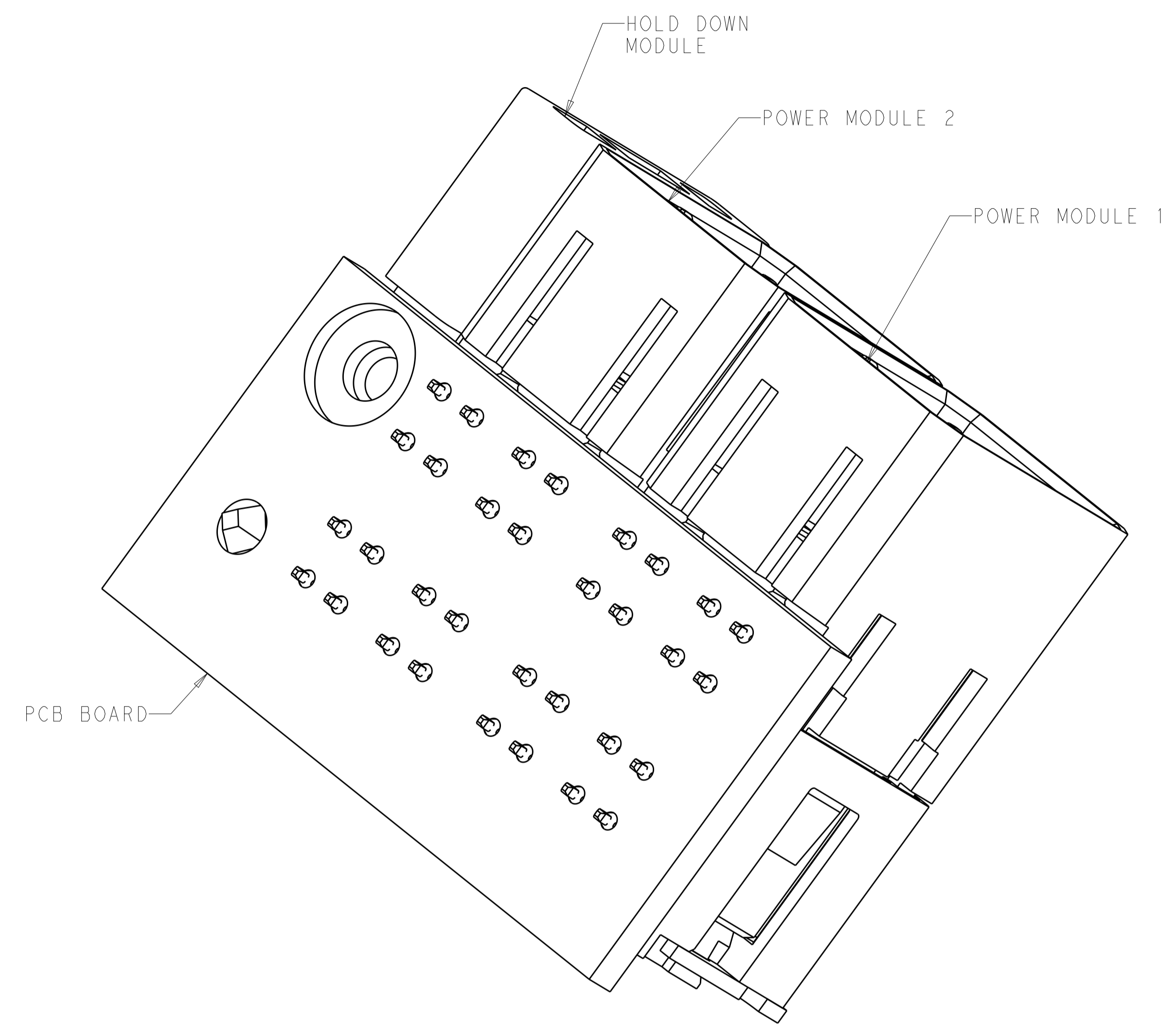

CONNECTOR WITH PCB BOARD

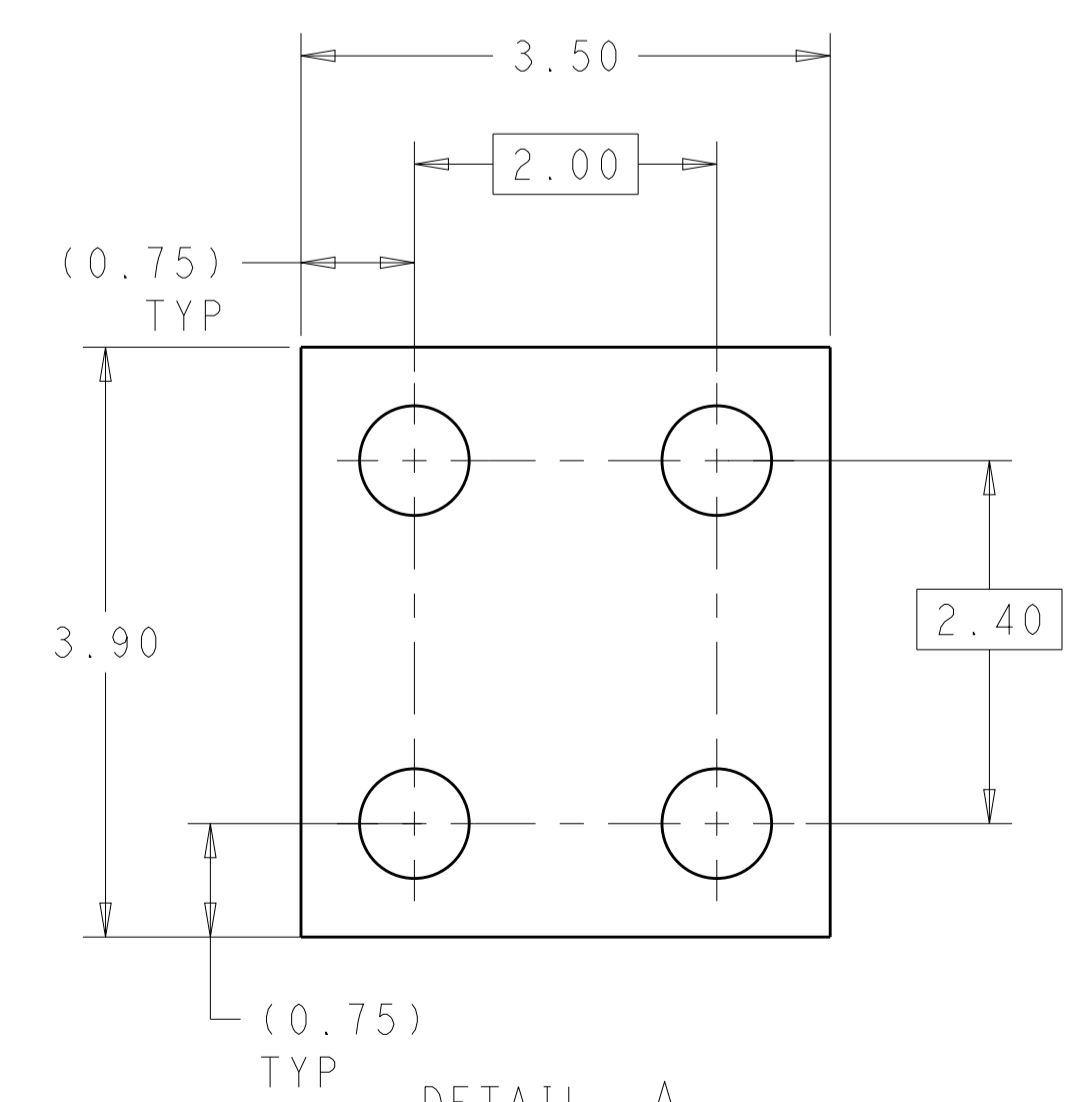

DETAIL A
 SCALE 20:1
 COPPER PAD REFERENCE

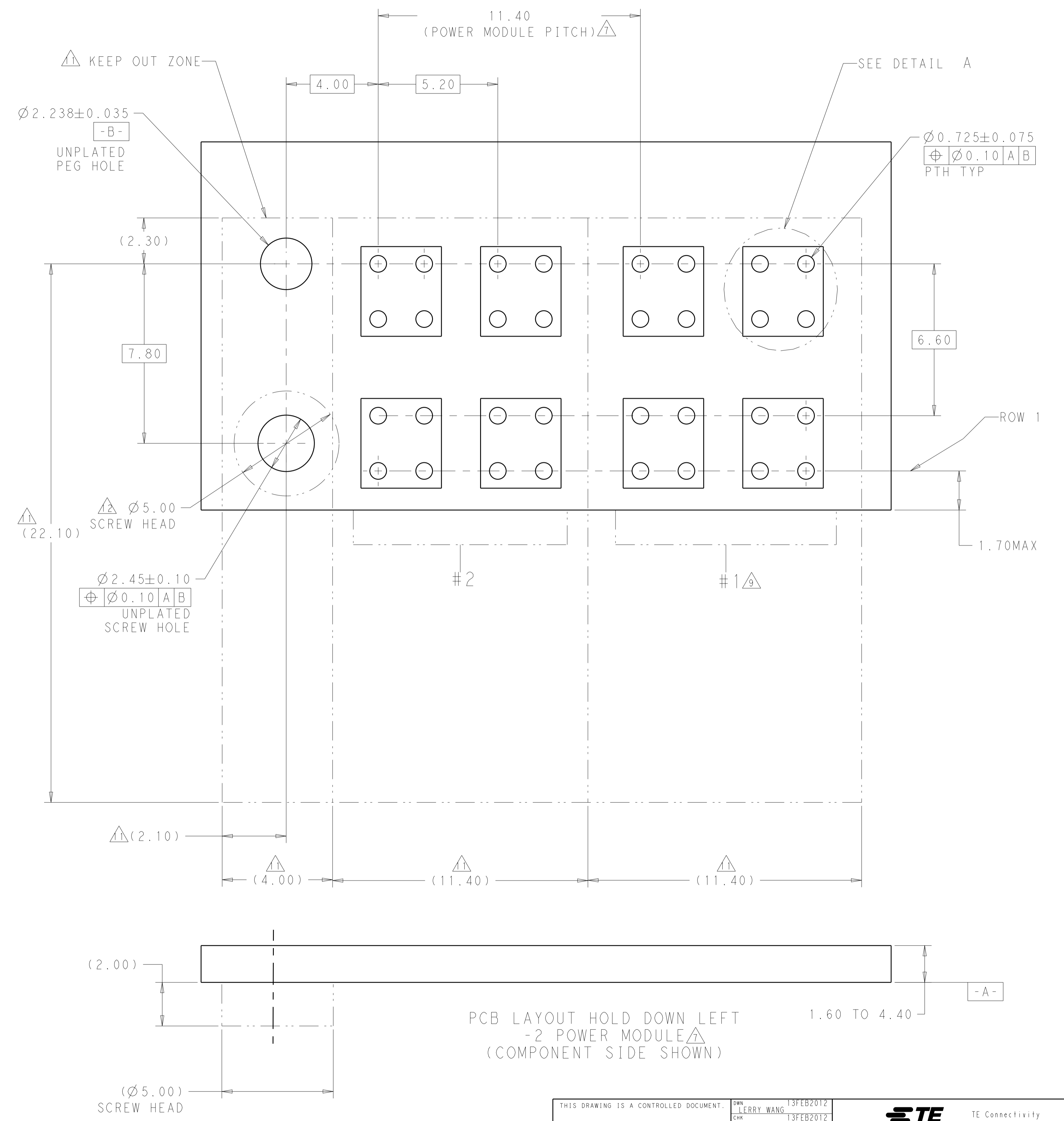

PCB LAYOUT HOLD DOWN LEFT
 - 2 POWER MODULE
 (COMPONENT SIDE SHOWN)

THIS DRAWING IS A CONTROLLED DOCUMENT.		OWN LERRY WANG 13FEB2012	TE Connectivity
DIMENSIONS: mm		CHK SUNY ZHAO 13FEB2012	
TOLERANCES UNLESS OTHERWISE SPECIFIED:		APVD SUNY ZHAO 13FEB2012	NAME
0 PLC	±	PRODUCT SPEC	IMPACT POWER 3 PAIR
1 PLC	±0.25	APPLICATION SPEC	R/A HEADER W/HOLD DOWN LEFT
2 PLC	±	SIZE	PRESS FIT
3 PLC	±	WEIGHT	
4 PLC	±	SCALE	4:1
ANGLES	±	CAGE CODE	114-32028
FINISH	±	DRAWING NO	A100779C=2180850
MATERIAL		RESTRICTED TO	
CUSTOMER DRAWING		SHEET	3 OF 3
		REV	A2