

# FL MC 10/100BASE-T/FO-660

Order No.: 2708193



<http://eshop.phoenixcontact.de/phoenix/treeViewClick.do?UID=2708193>

FO converter, for converting 10/100Base-T to polymer and HCS fiber, (660 nm), SCRJ FO connection (PROFINET standard), rail-mountable, supply 24 V DC



Ethernet



## Commercial data

GTIN (EAN)	 4 017918 973957
sales group	H650
Pack	1 pcs.
Customs tariff	85176200
Catalog page information	Page 546 (IF-2011)

## Product notes

WEEE/RoHS-compliant since:  
03/14/2007



<http://www.download.phoenixcontact.com>  
Please note that the data given here has been taken from the online catalog. For comprehensive information and data, please refer to the user documentation. The General Terms and Conditions of Use apply to Internet downloads.

## Technical data

### Serial interface

Interface 1	Ethernet interface, 10/100BASE-T(X) in acc. with IEEE 802.3u
Transmission length	100 m (twisted pair, shielded)
Connection method	RJ45 female connector, shielded
Auto-negotiation modes	Optionally transparent via TP and FO (default) or locally on TP

Link through	Link down is automatically forwarded to the second connection
MDI-/MDI-X switchover	Built-in switch for line (1:1) and crossover connection
Signal LEDs	Activity (yellow), link status (green, UL flashing), 100 Mbps (green)
Serial transmission speed	10/100 Mbps

#### Optical interface FO

Transmit capacity, minimum	min. -8 dBm ((980/1000 µm) static)
	min. -19 dBm ((200/230 µm) static)
Transmit capacity, maximum	max. -2 dBm ((980/1000 µm) static)
	max. -11 dBm ((200/230 µm) static)
Minimum receiver sensitivity	min. -23.00 dBm ((980/1000 µm) static)
	min. -26.80 dBm ((200/230 µm) static)
Wavelength	660 nm
Transmission length incl. 3 dB system reserve	70 m (Polymer fiber with F-P 980/1000 230 dB/km at 10 Mbps)
	300 m (HCS fiber with F-K 200/230 8 dB/km at 10 Mbps)
	50 m (Polymer fiber with F-P 980/1000 230 dB/km at 100 Mbps)
	100 m (HCS fiber with F-K 200/230 8 dB/km at 100 Mbps)
	300 m (HCS GI fiber with F-GK 200/230 at 100 Mbps)
Connection method	SCRJ

#### Switching output ODL

Name	Two floating relay outputs
Maximum switching voltage	max. 60 V AC/DC
Switching current	1 A

#### Power supply

Nominal supply voltage	24 V DC ±20 % (via pluggable COMBICON screw terminal block)
	24 V DC ±5% (as an alternative or redundant, via backplane bus contact and system current supply)
Typical current consumption	≤ 100 mA (24 V DC)
Protective circuit	Protection against polarity reversal
Connection method	Plug-in screw terminal block (COMBICON), redundancy possible

#### General data

Width	22.5 mm
Height	99 mm
Depth	114.5 mm

Ambient temperature (operation)	-20 °C ... 60 °C
Electrical isolation	(VCC // Ethernet)
Test voltage data interface/power supply	1500 V
	1.5 kV <sub>rms</sub> (50 Hz, 1 min.)
Electromagnetic compatibility	Conformance with EMC directive 89/336/EC
Noise emission	EN 50081-2
Noise immunity	EN 61000-6-2:2005
Degree of protection	IP20
Net weight	125 g
Housing material	PA V0, color green
Color	green
MTBF	564 Years (Telcordia standard, 25°C temperature, 21% operating cycle (5 days a week, 8 hours a day))
	136 Years (Telcordia standard, 40°C temperature, 34.25% operating cycle (5 days a week, 12 hours a day))
ATEX	Ex II 3 G Ex nAC IIC T4 X
UL, USA / Canada	cUL 508 Recognized

#### Certificates / Approvals



Certification CUL, UL

#### Accessories

Item	Designation	Description
<b>Cable/conductor</b>		
2744830	FL CAT5 FLEX	CAT5-SF/UTP cable (J-LI02YS(ST)C H 2 x 2 x 26 AWG), light-duty, flexible installation cable 2 x 2 x 0.14 mm <sup>2</sup> , stranded, shielded, outer sheath: 5.75 mm ± 0.15 mm diameter
2744814	FL CAT5 HEAVY	CAT5-SF/UTP cable (J-02YS(ST)C HP 2 x 2 x 24 AWG), heavy-duty installation cable, 2 x 2 x 0.22 mm <sup>2</sup> , solid conductor, shielded, outer sheath: 7.8 mm diameter, inner sheath: 5.75 mm ± 0.15 mm diameter
2313397	FL FOC PN-B-980/1000	PROFINET polymer fiber cable, duplex, 980/1000 µm, heavy-weight design, for permanent indoor installation, by the meter, without connector

2901234	FL FOC PN-B-HCS	HCS cable, duplex, 200/230 µm, sold by the meter with connectors, for indoor installation, type B, PVC outer cable sheath, 7 mm outside diameter, PROFINET certified, color: green
2313494	FL FOC PN-C-FLEX	PROFINET polymer fiber cable, duplex, 980/1000 µm, heavy highly-stranded version for drag chain applications, sold by the meter with connector
2313407	FL FOC PN-C-FLEX-980/1000	PROFINET polymer fiber cable, duplex, 980/1000 µm, heavy-weight highly flexible design, for flexible cable conduit applications, by the meter, without connector
2313504	FL FOC PN-C-HCS-GI	HCS GI cable for indoor installation, duplex, 200/230 µm, sold by the meter with connectors, particularly suitable for Ethernet applications due to the high bandwidth, rugged PUR outer cable sheath, 8 mm outside diameter, color: green
2799885	PSM-LWL-HCS-RUGGED-200/230	HCS cable, duplex 200/230 µm, by the meter, without connector, for indoor installation
2799445	PSM-LWL-HCSO-200/230	HCS cable, duplex 200/230 µm, by the meter, without connector, for outdoor installation
2744319	PSM-LWL-KDHEAVY-980/1000	Polymer fiber cable, duplex 980/1000 µm, medium-weight version for permanent indoor installation, by the meter, without connector
2744322	PSM-LWL-RUGGED-980/1000	Polymer fiber cable, duplex, 980 µm/1000 µm, heavy version for permanent indoor installation, sold by the meter without connectors
2744335	PSM-LWL-RUGGED-FLEX-980/1000	Polymer fiber cable, duplex 980/1000 µm, heavy-weight, highly flexible version for flexible conduit applications, by the meter, without connector
<b>General</b>		
2707437	ME 22,5 TBUS 1,5/ 5-ST-3,81 GN	DIN rail connector for current transducers, gold-plated contacts, for DIN rail mounting, 5-pos.
2866983	MINI-SYS-PS-100-240AC/24DC/1.5	DIN rail power supply unit, primary-switched mode, slim design, output: 24 V DC / 1.5 A
<b>Plug/Adapter</b>		
2744571	FL PLUG RJ45 GN/2	RJ45 connector, shielded, with bend protection sleeve, 2 pieces, green for crossed cables, for assembly on site. For connections that are crossed, it is recommended that the connector set with green bend protection sleeves is used.
2744856	FL PLUG RJ45 GR/2	RJ45 connector, shielded, with bend protection sleeve, 2 pieces, gray for straight cables, for assembly on site. For connections that are not crossed, it is recommended that you use the connector set with gray bend protection sleeve.
2313070	PSM-SET-SCRJ-DUP/2-HCS	SCRJ connector set for HCS fiber, for self assembly, consisting of 2 duplex quick mounting connectors with bending protection
2708656	PSM-SET-SCRJ-DUP/2-POF	SCRJ connector set for polymer fiber, for self assembly, consisting of 2 duplex quick mounting connectors with bending protection

**Tools**

2744869	FL CRIMPTOOL	Crimping pliers, for assembling the RJ45 connectors FL PLUG RJ45..., for assembly on site
2708876	PSM-HCS-KONFTOOL/SC-RJ	HCS assembly kit for SCRJ quick mounting connectors, including stripping blade, stripping pliers, aramide yarn scissors, fiber stripper, microscope, fiber cleaving tool for standard HCS and HCS GI fibers, and documentation
2708876	PSM-HCS-KONFTOOL/SC-RJ	HCS assembly kit for SCRJ quick mounting connectors, including stripping blade, stripping pliers, aramide yarn scissors, fiber stripper, microscope, fiber cleaving tool for standard HCS and HCS GI fibers, and documentation
1656673	VS-SCRJ-POF-POLISH	Refilling set for VS-SCRJ-POF-KONFTOOL-POLISH, consisting of two polishing discs and a polisher

**Diagrams/Drawings**

Block diagram

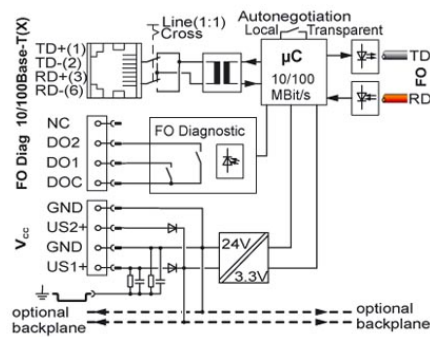

Functional drawing

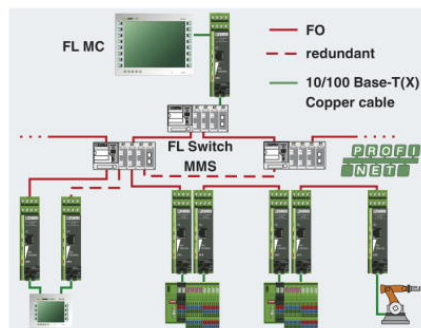

Star, linear, and redundant ring structure in combination with modular switches

**Address**

PHOENIX CONTACT Inc., USA  
586 Fulling Mill Road  
Middletown, PA 17057, USA  
Phone (800) 888-7388  
Fax (717) 944-1625  
<http://www.phoenixcon.com>



© 2011 Phoenix Contact  
Technical modifications reserved;