

LOC	DIST	REVISIONS			
P	LTR	DESCRIPTION	DATE	DWN	APVD
AF	50	1	PROPOSED	-	-

- 1 CONTINUOUS STRIP ON REELS WITH TERMINALS LOCATED ON 6.86±0.08 [.270±.003] CENTERS
- 2 SLOT ACCEPTS 0.91-1.15mm [#19-#17] AWG COPPER MAGNET WIRE. ONE WIRE MAX PER SLOT.
- 3 IDENTIFICATION NUMBER 24 FOR THE MAGNET WIRE SLOT SIZE.
- 4 0.25 [.010] MAX CARRIER CUT-OFF
- 5 PRELIMINARY - NOT FOR PRODUCTION

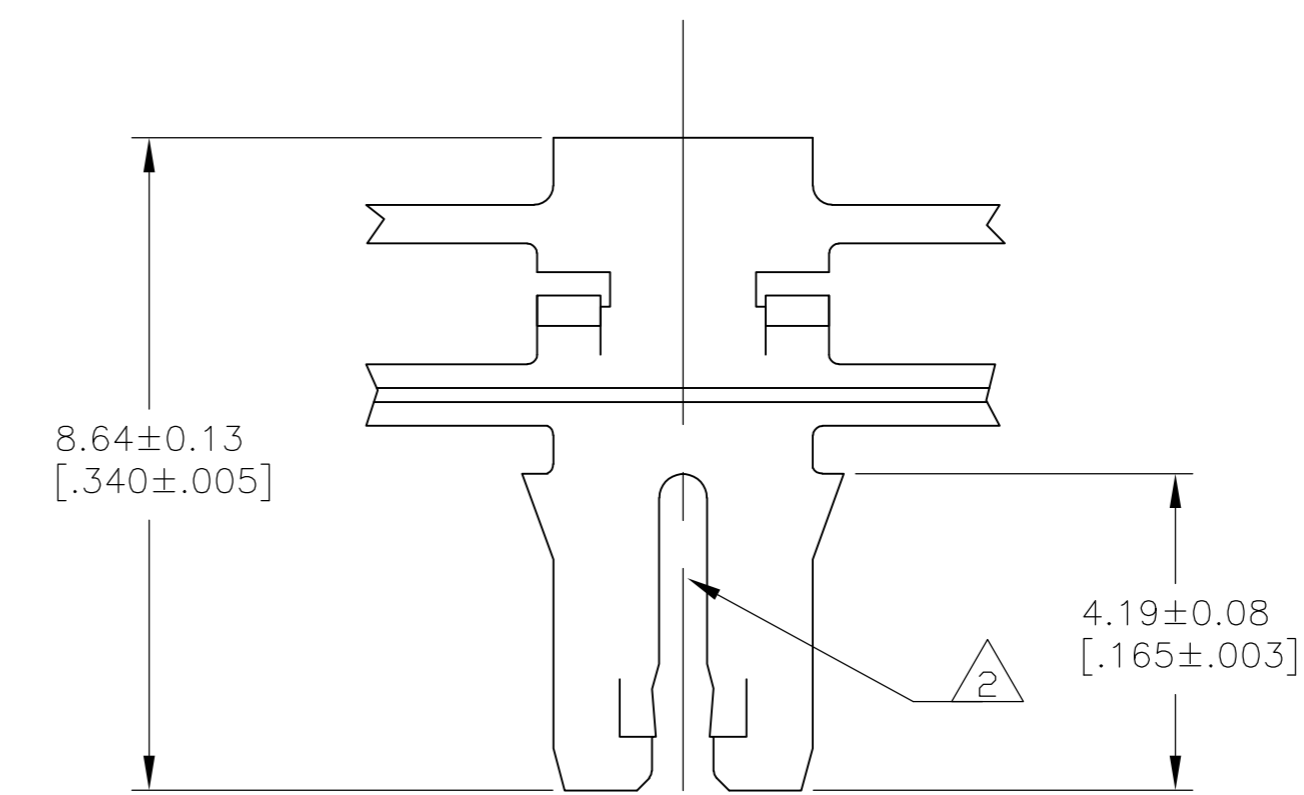
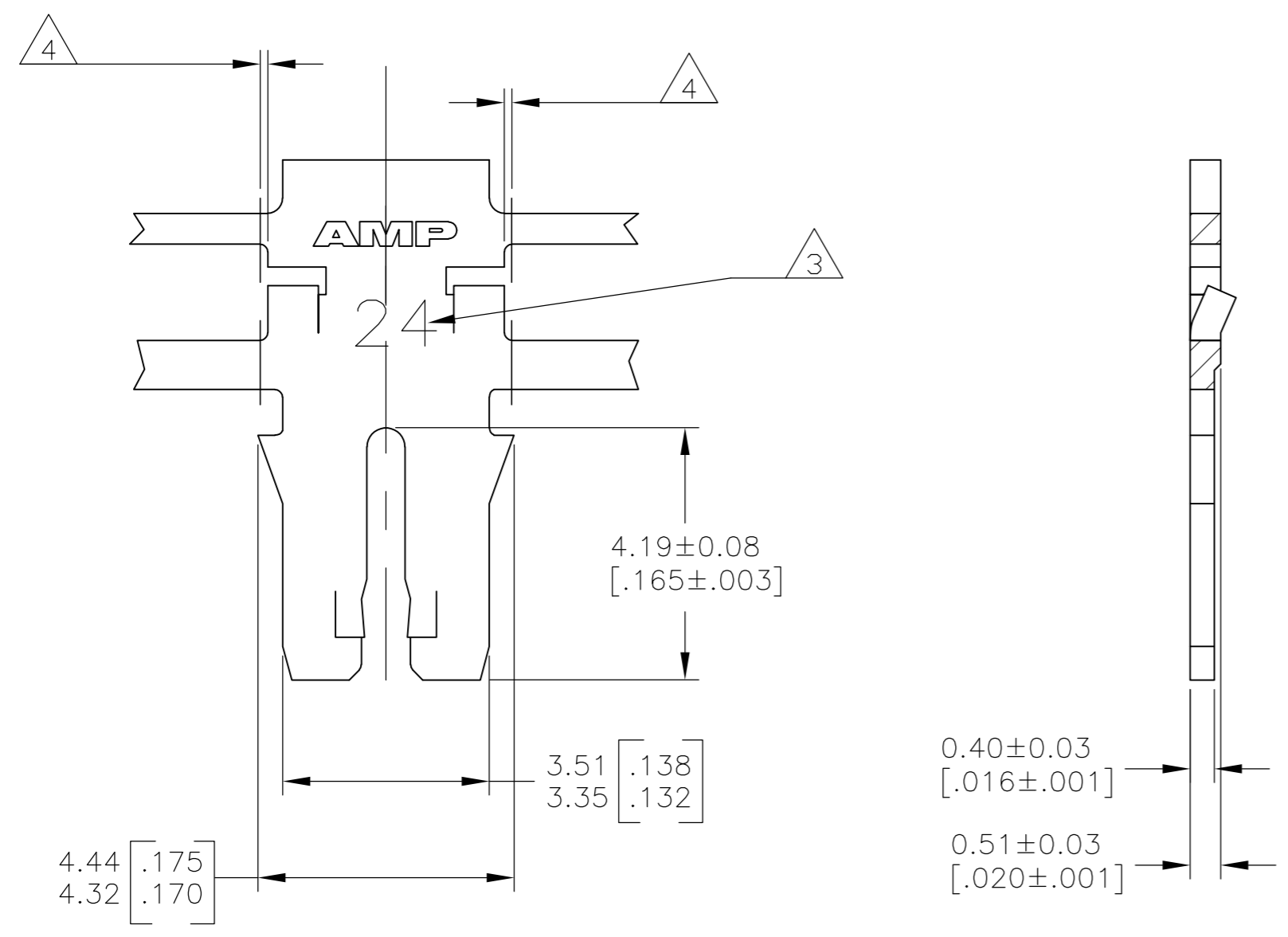

0.002032 [.000080] MIN TIN PLATE	082 PRE-MILLED BRASS	1742866-1
FINISH	MATERIAL	PART NO.

THIS DRAWING IS A CONTROLLED DOCUMENT.		DWN JR RUTH 27OCT10	Tyco Electronics Corporation Harrisburg, PA 17105-3608	
DIMENSIONS: MM [INCHES]		CHK KURT RANDOLPH 27OCT10	ABOLISHED NOT the LATEST REVISION	
TOLERANCES UNLESS OTHERWISE SPECIFIED:		APVD KURT RANDOLPH 27OCT10		
0 PLC ± -		PRODUCT SPEC		
1 PLC ± -		108-1484		
2 PLC ± 0.13 [.005]		APPLICATION SPEC	TAB, 4.75 [.187] SPECIAL, MAG-MATE™ Slim Line	
3 PLC ± -		114-2140	SIZE	CAGE CODE
4 PLC ± -		WEIGHT	A2	00779
ANGLES ± -		CUSTOMER DRAWING	SCALE	10:1
MATERIAL SEE TABLE		FINISH SEE TABLE	SHEET	1 OF 1
			REV	1