

THIS DRAWING IS UNPUBLISHED. RELEASED FOR PUBLICATION, 19 .
 © COPYRIGHT 19 BY AMP INCORPORATED. ALL INTERNATIONAL RIGHTS RESERVED.

LOC	DIST	P	F	ZONE	LTR	REVISIONS	DATE	APPD
CH	11					ECN96022902 OBSOLETE (PENDING) 192447-3	05/MAR/96	

- ① FINISH - SILVER PLATE, 200 MIN μINCHES THICK, PER AMP SPEC 112-32-1.
- ② FINISH - NICKEL PLATE, 100 MIN μINCHES THICK, PER AMP SPEC 112-246-1.
- ③ HARDWARE FURNISHED FOR:
 - 192447-7 2 NUTS, 2 WASHERS
 - 1-192447-1 2 NUTS, NO WASHERS
 - 1-192447-9 1 NUT, NO WASHERS
- ④ UNLESS OTHERWISE SPECIFIED, ø"F" EQUALS ø"C".

F	E	D	C	B	A	H'WARE INCL	FIGURE	FINISH (NOTE #)	WAS	PART NO.
-	-	9.4 [.37]	ø6.1 [.24]	1/2-20UNF-2A	31.7 [1.25]	NO	A	1	-	2-192447-0
-	-	17.0 [.67]	ø8.2 [.32]	9/16-18UNF-2A	34.2 [1.35]	YES	A	1	-	1-192477-9
-	-	17.0 [.67]	ø8.2 [.32]	9/16-18UNF-2A	34.2 [1.35]	NO	A	1	09112	1-192447-8
-	-	9.4 [.37]	ø4.1 [.16]	5/16-32UNEF-2A	19.6 [.77]	NO	A	1	-	1-192447-7
-	41.8 [1.64]	19.9 [.78]	ø35.0 [1.38]	M50 X 1.5-6g	62.0 [2.44]	NO	B	1	09133	1-192447-6
-	41.3 [1.62]	20.7 [.81]	ø30.0 [1.18]	M48 X 1.5-6g	62.0 [2.44]	NO	B	1	09079	1-192447-5
-	43.1 [1.69]	21.9 [.86]	ø25.0 [.98]	1 5/8-16UN-2A	62.2 [2.45]	NO	B	1	09165	1-192447-4
-	-	21.1 [.83]	ø20.1 [.79]	1 1/4-18UNEF-2A	42.2 [1.66]	NO	A	1	09173	1-192447-3
-	-	17.3 [.68]	ø12.0 [.47]	3/4-16UNF-2A	34.0 [1.34]	NO	A	1	10260	1-192447-2
-	-	17.0 [.67]	ø8.2 [.32]	9/16-18UNF-2A	34.2 [1.35]	YES	A	1	-	1-192447-1
-	-	8.4 [.33]	ø2.3 [.09]	5/16-32UNEF-2A	16.5 [.65]	NO	A	1	09183	1-192447-0
-	-	9.4 [.37]	ø4.1 [.16]	M8 X 0.75-6g	19.6 [.77]	NO	A	1	09026	192447-9
-	-	9.4 [.37]	ø4.1 [.16]	5/16-32UNEF-2A	19.6 [.77]	NO	A	1	09111	192447-8
-	-	9.4 [.37]	ø4.1 [.16]	5/16-32UNEF-2A	19.6 [.77]	YES	A	2	10244	192447-7
-	-	14.5 [.57]	ø4.1 [.16]	5/16-32UNEF-2A	28.4 [1.12]	NO	A	1	10394	192447-6
ø4.3 [.17]	-	14.5 [.57]	ø4.1 [.16]	5/16-32UNEF-2A	38.1 [1.50]	NO	A	1	10611	192447-5
-	-	9.4 [.37]	ø6.1 [.24]	1/2-28UNEF-2A	19.6 [.77]	NO	A	1	10934	192447-4
-	-	9.4 [.37]	ø6.1 [.24]	1/2-20UNF-2A	19.6 [.77]	NO	A	2	10263	192447-3
-	-	9.4 [.37]	ø6.1 [.24]	1/2-20UNF-2A	19.6 [.77]	NO	A	1	09182	192447-2
-	-	19.2 [.76]	ø16.1 [.63]	15/16-20UNEF-2A	38.1 [1.50]	NO	A	1	09066	192447-1

OBSOLETE (PENDING)

DO NOT SCALE PRINT. UNLESS SPECIFIED DIMENSIONS IN mm [INCHES] TOLERANCES ON :
 1 PLC DEC ± 0.5 [.02]
 2 PLC DEC ± 0.25 [.010]
 ANGLES ± -
 MATERIAL BRASS
 FINISH ①②

DR D. WILSON 04-02-92
 CHK R. JAYNE 5-04-92
 APPD A. GRIFFIN 5-04-92
 APPD P. GLASER 5-06-92
 APPLICATION SPEC -
 WEIGHT -

AMP AMP Incorporated
 Harrisburg, PA 17105-3608

NAME
THREADED SLEEVE SOCKET ASSY

SIZE	CAGE CODE	DRAWING NO
③	00779	192447
SCALE	NONE	SHEET 1 OF 2

LOC		DIST		P		F		ZONE		LTR		REVISIONS		DATE	APPD
CH	11												SEE SHEET ONE	05-12-93	

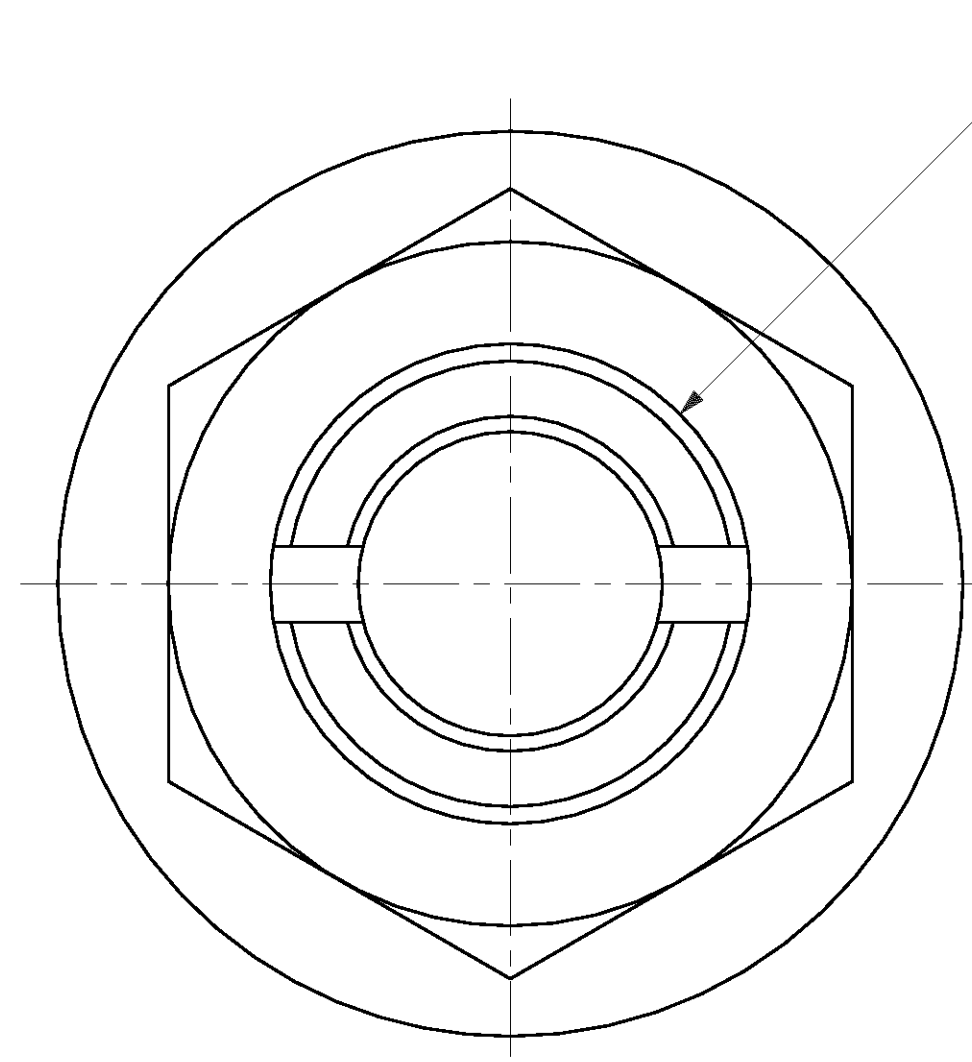
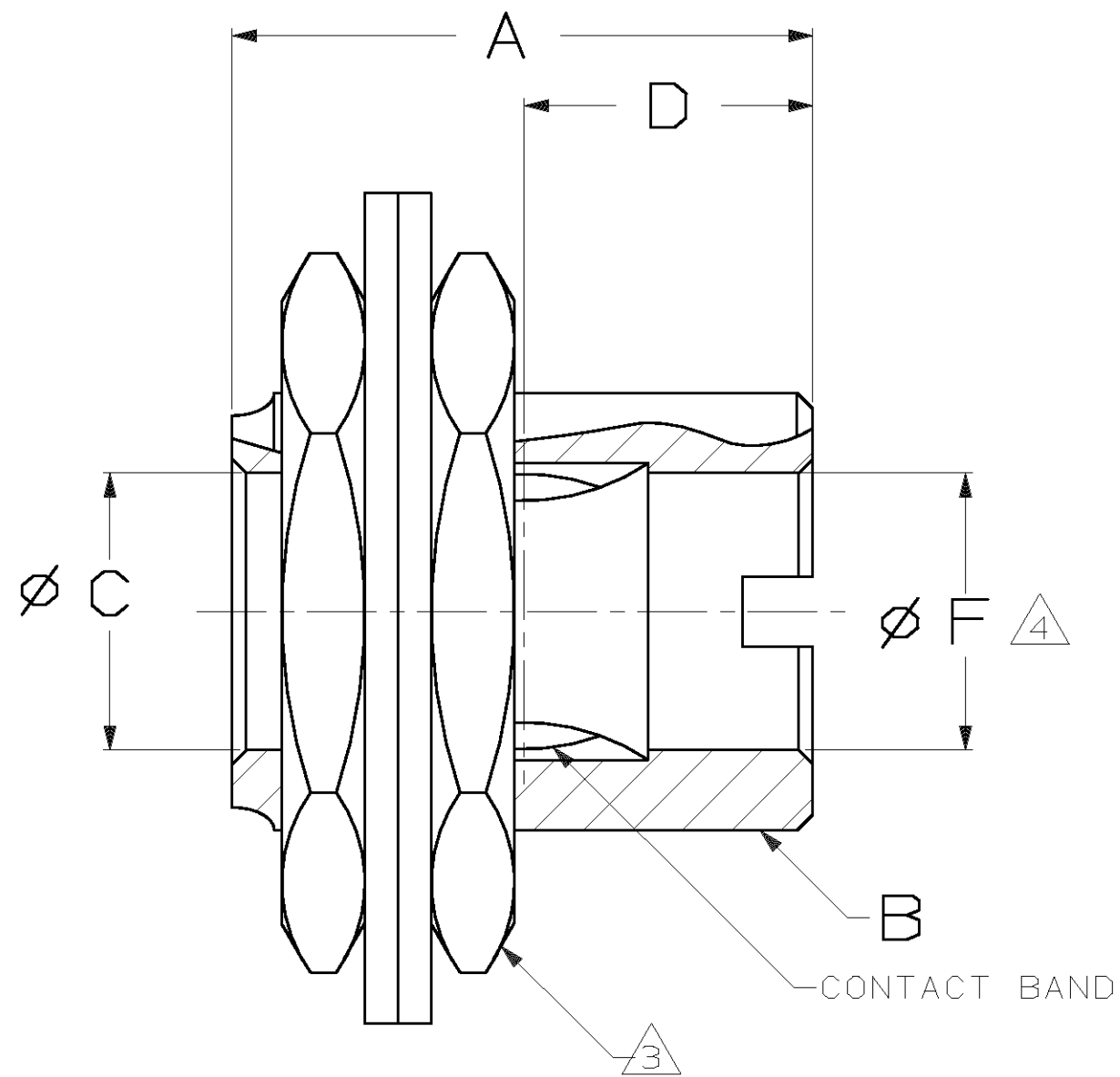

FIGURE A
(SINGLE CAVITY)

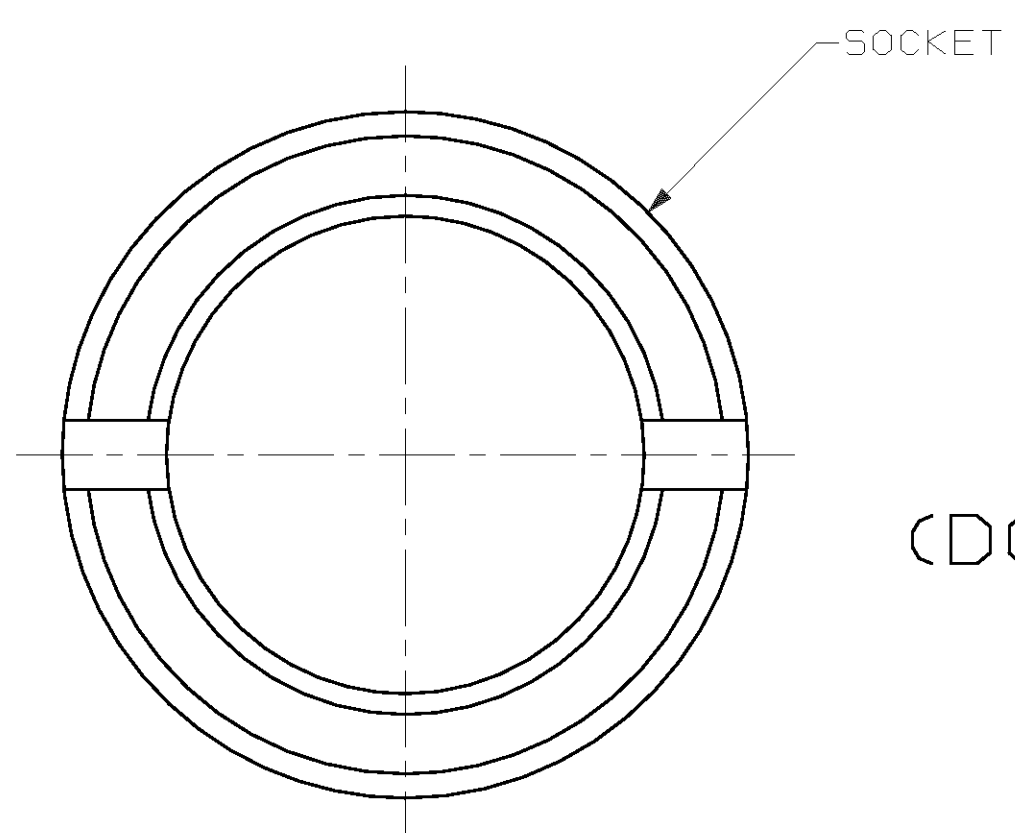
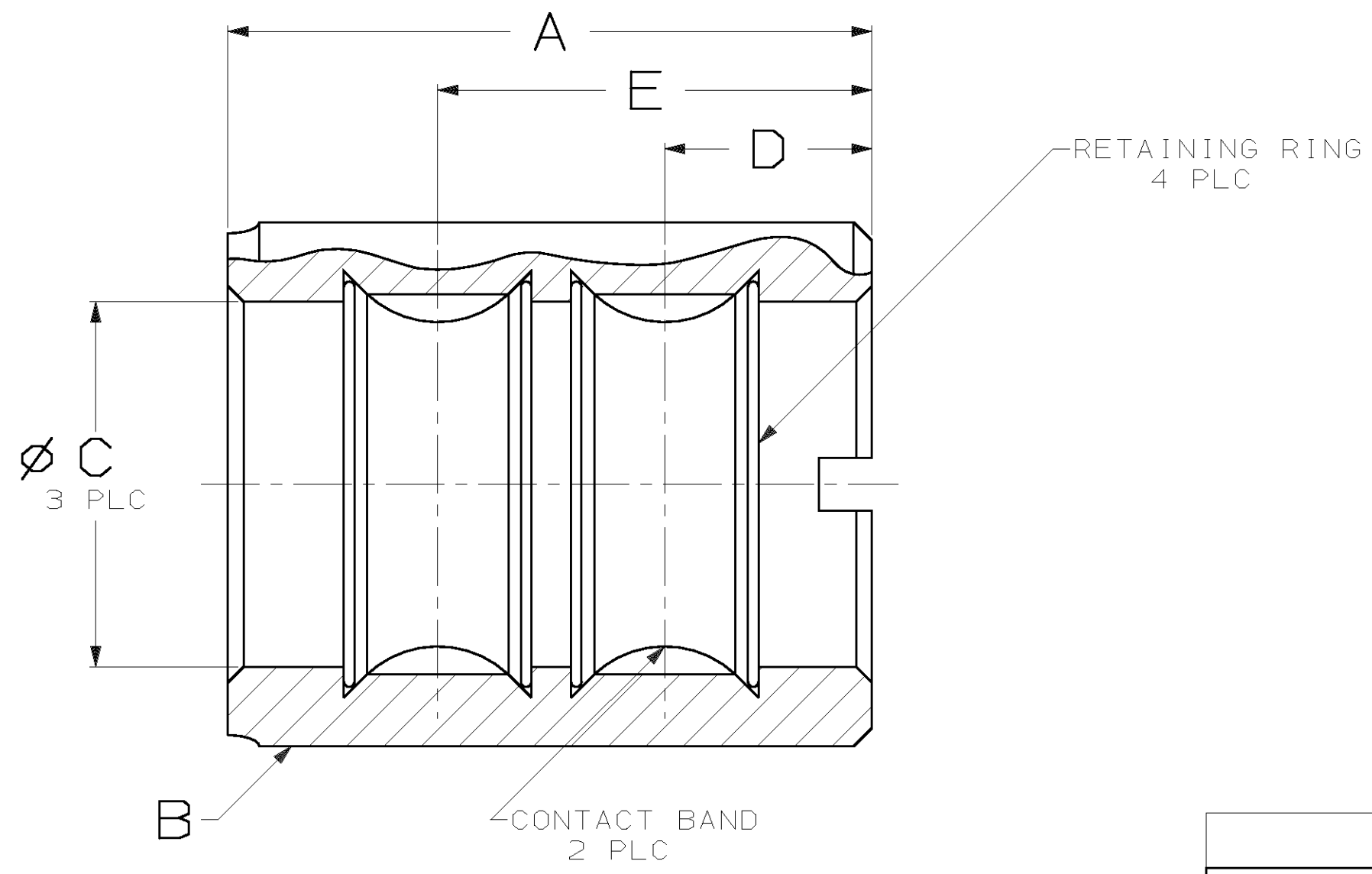

FIGURE B
(DOUBLE CAVITY)

DO NOT SCALE PRINT. UNLESS SPECIFIED DIMENSIONS IN mm [INCHES] TOLERANCES ON : 1 PLC DEC ± 0.5 [.02] 2 PLC DEC ± 0.25 [.010] ANGLES ± -	DR D. WILSON 04-02-92	AMP AMP Incorporated Harrisburg, PA 17105-3608		
	CHK R. JAYNE 5-04-92			
MATERIAL -	APPD A. GRIFFIN 5-04-92	NAME		
	APPD P. GLASER 5-06-92	THREADED SLEEVE SOCKET ASSY		
FINISH -	APPLICATION SPEC	SIZE	CAGE CODE	DRAWING NO
	WEIGHT	-	③ 00779	192447
		SCALE	NONE	SHEET 2 OF 2