

Type 2 surge protection plug - VAL-MS 350 VF ST - 2856595

Please be informed that the data shown in this PDF Document is generated from our Online Catalog. Please find the complete data in the user's documentation. Our General Terms of Use for Downloads are valid (<http://phoenixcontact.com/download>)



surge protection connector type 2 with series connection consisting of varistor and gas-filled spark gap for VAL-MS base element, thermal monitoring, visual fault warning. Design: 350 V AC

The figure shows the VAL-MS 75 VF ST version



Key Commercial Data

Packing unit	1 STK
GTIN	 4 017918 876869
GTIN	4017918876869
Weight per Piece (excluding packing)	40.000 g
Custom tariff number	85363010
Country of origin	Germany

Technical data

Dimensions

Height	52.4 mm
Width	17.5 mm
Depth	55.3 mm
Horizontal pitch	1 Div.

Ambient conditions

Degree of protection	IP20
Ambient temperature (operation)	-40 °C ... 80 °C
Ambient temperature (storage/transport)	-40 °C ... 80 °C

Type 2 surge protection plug - VAL-MS 350 VF ST - 2856595

Technical data

Ambient conditions

Altitude	≤ 2000 m (amsl (above mean sea level))
Permissible humidity (operation)	5 % ... 95 %
Shock (operation)	25g (Half-sine / 11 ms /3x, #X, #Y, #Z)
Vibration (operation)	5g (10 ... 500 Hz / 2.5 h / X, Y, Z)

General

IEC test classification	II
	T2
EN type	T2
IEC power supply system	TN
	TT
	IT
Mode of protection	L-N
	L-PE
	L-PEN
Mounting type	on base element
Color	jet black RAL 9005
Housing material	PA 6.6
Degree of pollution	2
Flammability rating according to UL 94	V-0
Type	DIN rail module, two-section, divisible
Number of positions	1
Arrester can be tested with CHECKMASTER from software version:	From SW rev. 1.12
Surge protection fault message	optical

Additional descriptions

Note	Usable in all low-voltage systems between L-N or L-PEN. Only usable in IT Systems between L-PE, if the exposed-conductive-parts (bodies) of the equipment of the low-voltage installation is connected to the earthing arrangement of the transformer substation. (interconnected earthing arrangement of the HV-transformer substation with the bodies of the LV-installation. $R_E = R_A$ accordance to IEC 60364-4-442 / VDE 0100-442 Fig. 44D / Example a)
------	---

Protective circuit

Nominal voltage U_N	240/415 V AC (TN)
	240/415 V AC (TT)
	230 V AC (IT)
Nominal frequency f_N	50 Hz (60 Hz)
Maximum continuous voltage U_C	350 V AC
Residual current I_{PE}	≤ 5 μ A

Type 2 surge protection plug - VAL-MS 350 VF ST - 2856595

Technical data

Protective circuit

Standby power consumption P_C	≤ 2 mVA
Nominal discharge current I_n (8/20) μ s	10 kA
Maximum discharge current I_{max} (8/20) μ s	20 kA
Short-circuit current rating I_{SCCR}	25 kA
Voltage protection level U_p	≤ 1.5 kV
Residual voltage U_{res}	≤ 1.2 kV (at I_n)
	≤ 1.2 kV (at 10 kA)
	≤ 1.1 kV (at 5 kA)
Front of wave sparkover voltage at 6 kV (1.2/50) μ s	≤ 1.5 kV
TOV behavior at U_T	415 V AC (5 s / withstand mode)
	440 V AC (120 min / withstand mode)
Response time t_A	≤ 100 ns
Max. backup fuse with branch wiring	125 A (gG)

Connection data

Connection method	VALVETRAB plug-in system
-------------------	--------------------------

UL specifications

SPD Type	4CA
Maximum continuous operating voltage MCOV (L-N)	350 V AC
Nom. voltage	350 V AC
Mode of protection	L-N
Power distribution system	1
Nominal frequency	50/60 Hz
Measured limiting voltage MLV (L-N)	1610 V
Nominal discharge current I_n (L-N)	10 kA

Environmental Product Compliance

China RoHS	Environmentally friendly use period: unlimited = EFUP-e
	No hazardous substances above threshold values

Drawings

Type 2 surge protection plug - VAL-MS 350 VF ST - 2856595

Circuit diagram



Dimensional drawing

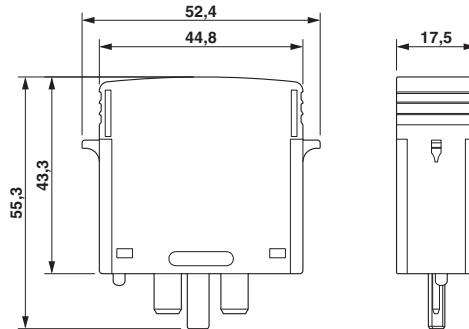

Classifications

eCl@ss

eCl@ss 4.0	27140201
eCl@ss 4.1	27130801
eCl@ss 5.0	27130801
eCl@ss 5.1	27130801
eCl@ss 6.0	27130805
eCl@ss 7.0	27130805
eCl@ss 8.0	27130890
eCl@ss 9.0	27130890

ETIM

ETIM 2.0	EC000941
ETIM 3.0	EC000941
ETIM 4.0	EC000941
ETIM 5.0	EC002496
ETIM 6.0	EC000941

UNSPSC

UNSPSC 6.01	30212010
UNSPSC 7.0901	39121610
UNSPSC 11	39121610
UNSPSC 12.01	39121610
UNSPSC 13.2	39121620

Approvals

Approvals

Type 2 surge protection plug - VAL-MS 350 VF ST - 2856595

Approvals

Approvals

IECEE CB Scheme / UL Recognized / KEMA-KEUR / ÖVE / cUL Recognized / CCA / CSA / EAC / EAC / cULus Recognized

Ex Approvals

Approval details

IECEE CB Scheme		http://www.iecee.org/	AT 2905/M1
UL Recognized		http://database.ul.com/cgi-bin/XYV/template/LISEXT/1FRAME/index.htm	FILE E 330181
KEMA-KEUR		http://www.dekra-certification.com	2170208.01
ÖVE		https://www.ove.at/en/certification-pz/certification-register/	18583-001-13
cUL Recognized		http://database.ul.com/cgi-bin/XYV/template/LISEXT/1FRAME/index.htm	FILE E 330181
CCA			NTR-AT 1947-A
CSA		http://www.csagroup.org/services-industries/product-listing/	13631
EAC			EAC-Zulassung

Type 2 surge protection plug - VAL-MS 350 VF ST - 2856595

Approvals

EAC		RU C- DE.A*30.B01561
-----	--	-------------------------

cULus Recognized		http://database.ul.com/cgi-bin/XYV/template/LISEXT/1FRAME/index.htm
------------------	--	---

Accessories

Accessories

Device marking

Zack marker strip - ZBN 18:UNBEDRUCKT - 2809128



Zack marker strip, Strip, white, unlabeled, can be labeled with: CMS-P1-PLOTTER, PLOTMARK, mounting type: snap into tall marker groove, for terminal block width: 18 mm, lettering field size: 18 x 5 mm

Zack marker strip - ZBN 18:UNBEDRUCKT - 2809128



Zack marker strip, Strip, white, unlabeled, can be labeled with: CMS-P1-PLOTTER, PLOTMARK, mounting type: snap into tall marker groove, for terminal block width: 18 mm, lettering field size: 18 x 5 mm

Labeled device marker

Marker for terminal blocks - ZBN 18,LGS:ERDE - 2749589



Marker for terminal blocks, Strip, white, labeled, Horizontal: Grounding symbol, mounting type: snap into tall marker groove, for terminal block width: 18 mm, lettering field size: 18 x 5 mm

Type 2 surge protection plug - VAL-MS 350 VF ST - 2856595

Accessories

Marker for terminal blocks - ZBN 18,LGS:L1-N,ERDE - 2749576



Marker for terminal blocks, Strip, white, labeled, Horizontal: L1, L2, L3, N, GND, mounting type: snap into tall marker groove, for terminal block width: 18 mm, lettering field size: 18 x 5 mm

Marker for terminal blocks - ZBN 18,LGS:ERDE - 2749589



Marker for terminal blocks, Strip, white, labeled, Horizontal: Grounding symbol, mounting type: snap into tall marker groove, for terminal block width: 18 mm, lettering field size: 18 x 5 mm

Marker for terminal blocks - ZBN 18,LGS:L1-N,ERDE - 2749576



Marker for terminal blocks, Strip, white, labeled, Horizontal: L1, L2, L3, N, GND, mounting type: snap into tall marker groove, for terminal block width: 18 mm, lettering field size: 18 x 5 mm

Marker pen

Marker pen - B-STIFT - 1051993



Marker pen, for manual labeling of unprinted Zack strips, smear-proof and waterproof, line thickness 0.5 mm

Additional products

Type 2 surge protection base element - VAL-MS BE - 2817741



Base element for type 2 arresters of the VALVETRAB MS series of products. Design: 1-channel

Type 2 surge protection plug - VAL-MS 350 VF ST - 2856595

Accessories

Type 2 surge protection base element - VAL-MS BE/FM - 2817738



Base element for type 2 arresters of the VALVETRAB MS series of products, with remote indication contact. Design: 1-channel
