

Sample set - SAMPLEPTSM 0,5/ 6-HHI0-2,5SMDWH - 1820822

Please be informed that the data shown in this PDF Document is generated from our Online Catalog. Please find the complete data in the user's documentation. Our General Terms of Use for Downloads are valid (<http://phoenixcontact.com/download>)



Header, Nominal current: 6 A, Rated voltage (III/2): 160 V, Number of positions: 6, Pitch: 2.5 mm, Color: white, Contact surface: Tin, Mounting: SMD soldering

The illustration shows a 3-position version

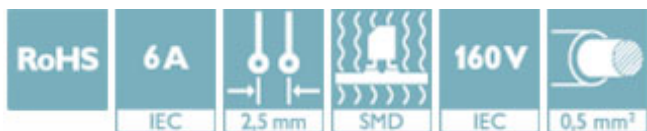

Key Commercial Data

Packing unit	5 STK
Minimum order quantity	5 STK
GTIN	 4 046356 787499
GTIN	4046356787499
Custom tariff number	85369010

Technical data

Dimensions

Length	12 mm
Pitch	2.50 mm
Dimension a	12.5 mm
Height	5 mm

General

Range of articles	PTSM 0,5/..-HHI-SMD WH
Insulating material group	I
Rated surge voltage (III/3)	2.5 kV
Rated surge voltage (III/2)	2.5 kV
Rated surge voltage (II/2)	2.5 kV
Rated voltage (III/3)	63 V
Rated voltage (III/2)	160 V
Rated voltage (II/2)	400 V
Nominal current I _N	6 A

Sample set - SAMPLEPTSM 0,5/ 6-HHI0-2,5SMDWH - 1820822

Technical data

General

Maximum load current	6 A
Insulating material	HT PA
Flammability rating according to UL 94	V0
Color	white
Number of positions	6

Standards and Regulations

Flammability rating according to UL 94	V0
--	----

Environmental Product Compliance

China RoHS	Environmentally friendly use period: unlimited = EFUP-e
	No hazardous substances above threshold values

Drawings

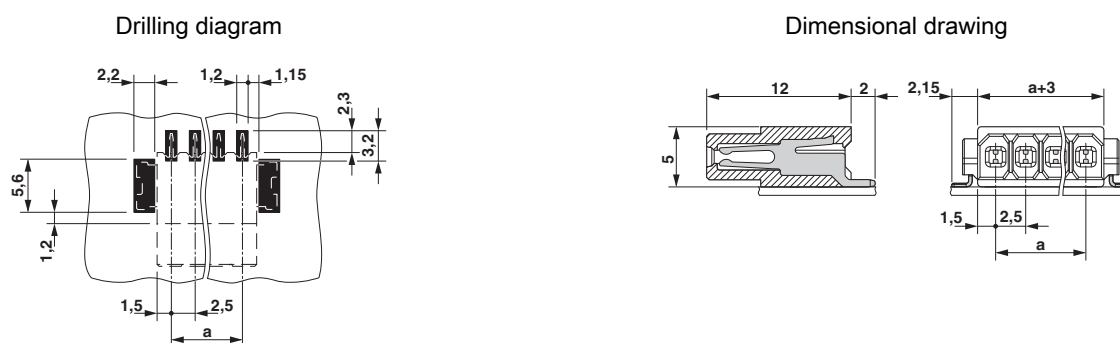

Approvals

Approvals

Approvals

EAC

Ex Approvals

Approval details

EAC B.01742

Mouser Electronics

Authorized Distributor

Click to View Pricing, Inventory, Delivery & Lifecycle Information:

[Phoenix Contact:](#)

[1820822](#)