

ISS.	DATE	E.C.N.	DESCRIPTION
1	5-Mar-09		FIRST ISSUE

© 2006 CARCLO  
ALL DIMENSIONS IN mm

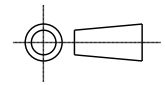

CUSTOMER DRAWING

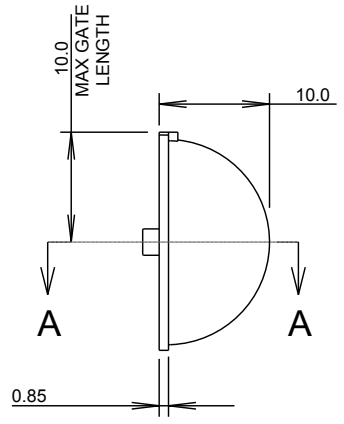
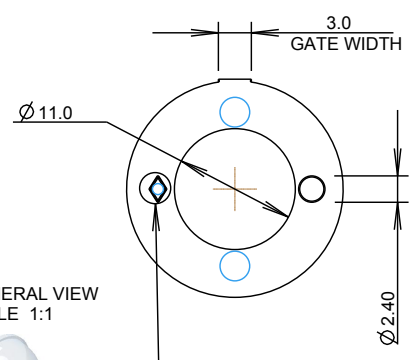
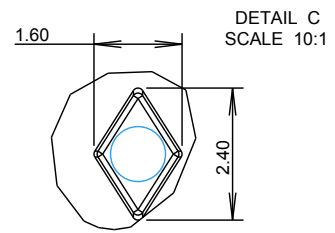
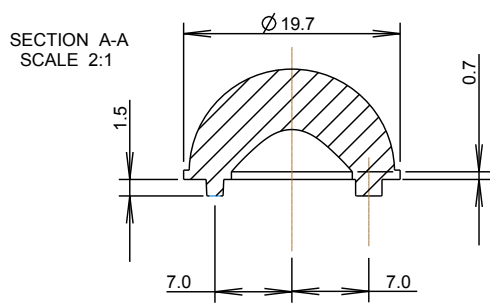

MATERIAL: POLYCARBONATE

3D GENERAL VIEW  
SCALE 1:1



DIAMOND DOWEL  
SEE DETAIL C



CARCLO TECHNICAL PLASTICS (SLOUGH)  
111 BUCKINGHAM AVE, SLOUGH  
SL1 4PF, ENGLAND  
TEL: +44 1753 575011 FAX: +44 1753 811359  
e-mail: design@carclo-optics.com

GENERAL TOLERANCES (UNLESS STATED)

LINEAR	ANGULAR
X +/- 0.25	X +/- 1°
X.X +/- 0.1	X.X +/- 0.5°
X.XX +/- 0.05	X.XX +/- 0.1°

CUSTOMER

CARCLO

TITLE

DOWNLIGHT  
BUBBLE OPTIC

DRAWN

AJD

DATE

5-Mar-09

CHK'D

DATE

APP'D

DATE

SCALE

2:1

CARCLO PART No.

10628

SIZE

A4

CARCLO DRG. No.

60586

SHEET

1 OF 2

ISS.	DATE	E.C.N.	DESCRIPTION
1	5-Mar-09		FIRST ISSUE

© 2006 CARCLO  
ALL DIMENSIONS IN mm

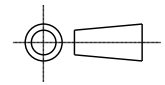

### PCB GLUE PAD AND ALIGNMENT HOLE LAYOUT DIMENSIONS

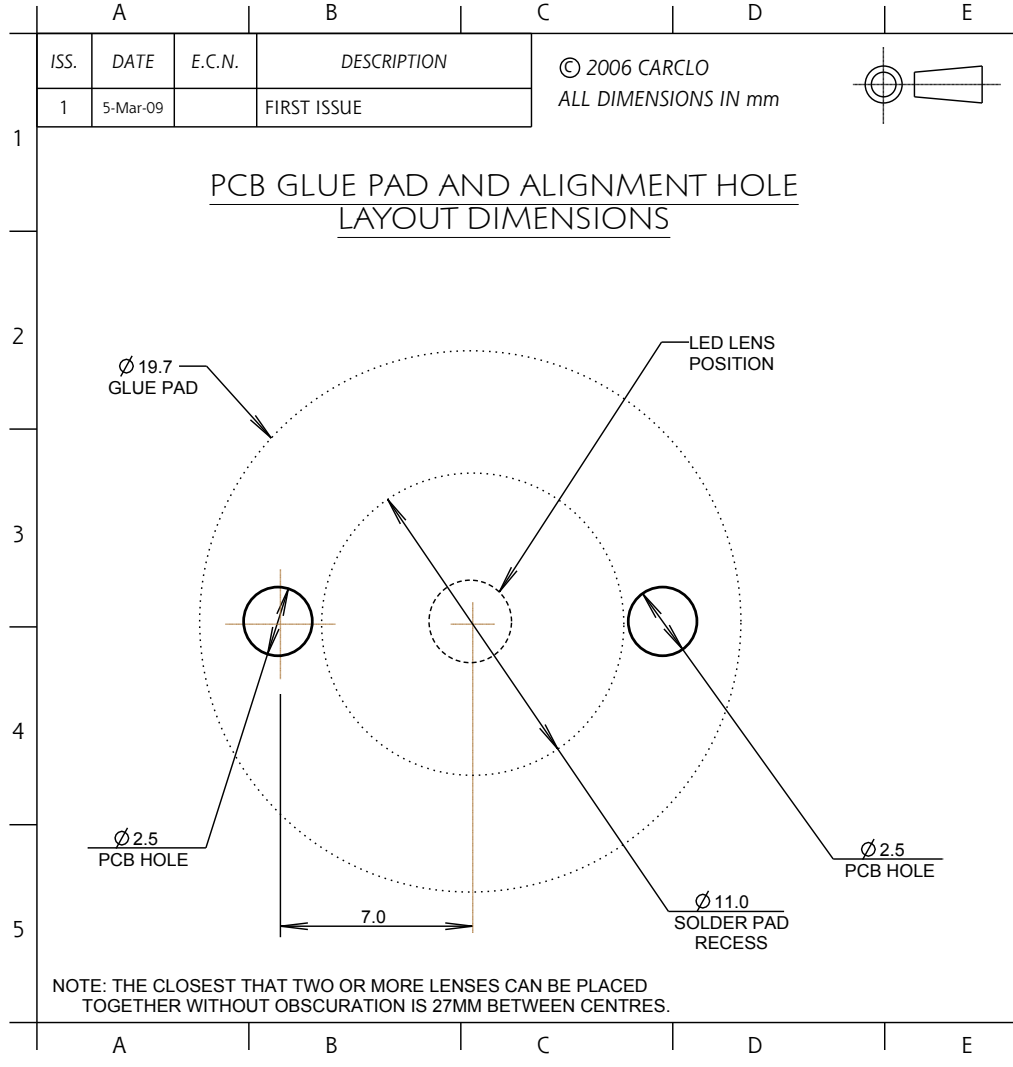

NOTE: THE CLOSEST THAT TWO OR MORE LENSES CAN BE PLACED TOGETHER WITHOUT OBSCURATION IS 27MM BETWEEN CENTRES.



**CARCLO TECHNICAL PLASTICS (SLOUGH)**  
111 BUCKINGHAM AVE, SLOUGH  
SL1 4PF, ENGLAND  
TEL: +44 1753 575011 FAX: +44 1753 811359  
e-mail: design@carclo-optics.com

GENERAL TOLERANCES (UNLESS STATED)	
LINEAR	ANGULAR
X +/- 0.25	X +/- 1°
X.X +/- 0.1	X.X +/- 0.5°
X.XX +/- 0.05	X.XX +/- 0.1°

CUSTOMER  
**CARCLO**

TITLE  
**DOWNLIGHT BUBBLE OPTIC**

DRAWN **AJD** DATE **5-Mar-09**

CHK'D \_\_\_\_\_ DATE \_\_\_\_\_

APP'D \_\_\_\_\_ DATE \_\_\_\_\_

SCALE <b>5:1</b>	CARCLO PART No. <b>10628</b>
---------------------	---------------------------------

SIZE <b>A4</b>	CARCLO DRG. No. <b>60586</b>	SHEET <b>2 OF 2</b>
-------------------	---------------------------------	------------------------