

PART NUMBER	REV	FIRST USED	POWER UNIT	FEED TYPE
1852593-1	C	122500-1	LEADMAKER & BENCH MODEL G	POST FEED
1852593-2	C	565435-5	BENCH MODEL K	POST FEED
7-1852593-7	A	-	SPARE PARTS	-

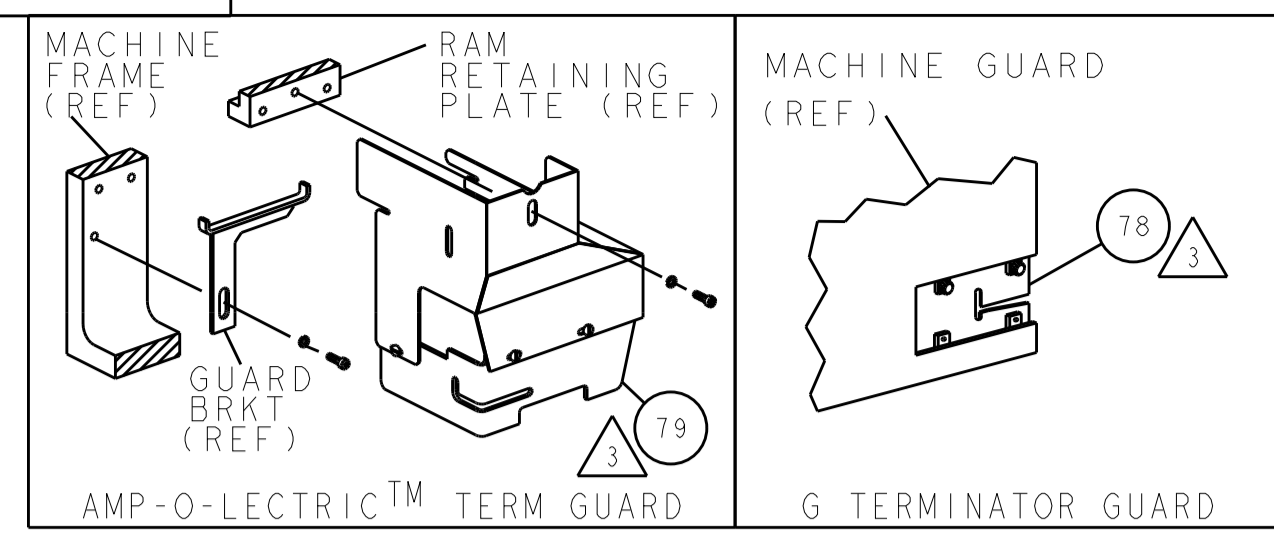

TERMINAL NAME: RECEPTACLE, POSITIVE LOCK, 6.35 [.250] SERIES				
1742630	-	TE TERMINAL - TE CRIMP SPECS		
-	-	PAD LTR	CRIMP HEIGHT	WIRE SIZE
-	-	A	1.24±0.05mm [.049±.002]	18AWG
-	-	B	1.12±0.05mm [.044±.002]	20AWG
-	-	C	1.07±0.05mm [.042±.002]	22AWG
-	-	D	-	-
-	-	CRIMP	SIZE	TYPE
-	-	WIRE	2.03mm [.080]	F
-	-	INSUL	4.57mm [.180]	F
WIRE STRIP LENGTH	TERM APPL SPEC	FEED	APPL INSTRUCTIONS	SET UP GAGE
4.39-5.17mm	114-2074	21.46mm	408-8039	458638-1

LOC	DIST	REV	DATE	BY	CHK	APPV
A	66	B	31AUG2011	RK	GB	
		C	02JUL2013	XZ	TE	

- △ RECOMMENDED SPARE PARTS
- △ GREASE LIGHTLY
- △ GUARD MUST BE IN PLACE WHEN OPERATING APPLICATOR IN A BENCH MACHINE

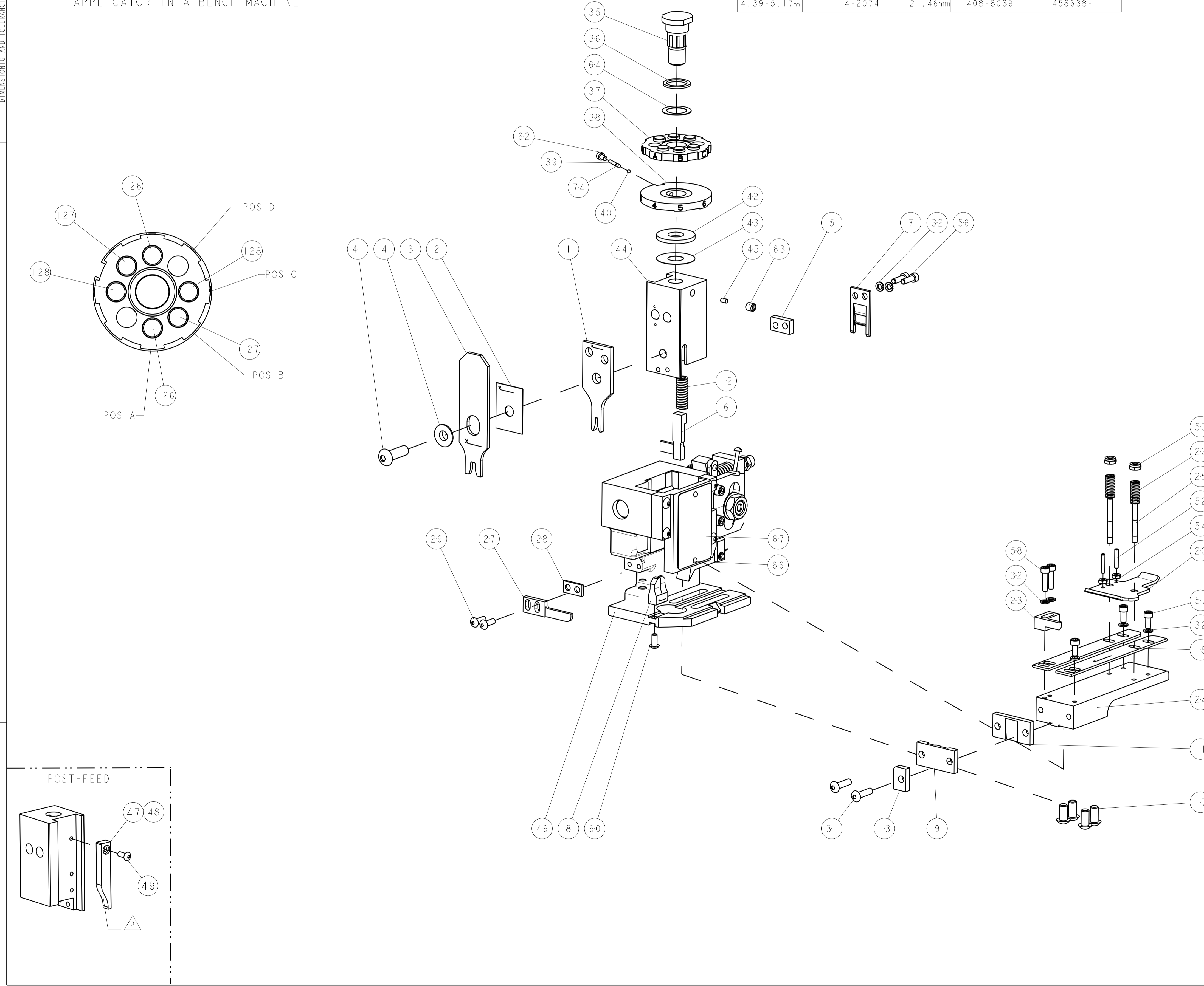

2	2	-	5-354779-1	PIN, WIRE DISC, .3245	128
2	2	-	4-354779-6	PIN, WIRE DISC, .3220	127
2	2	-	3-354779-6	PIN, WIRE DISC, .3170	126
REF	-	-	455745-1	GUARD WINDOW	79
REF	REF	-	679532-1	INSERT, GUARD	78
1	1	-	690603-1	SPRING ASSIST AMP-O-MATOR APPLICATOR	74
1	1	-	217238-1	GENERAL INSTRUCTION PKG	72
1	1	-	4088039	EF APPL INST 408-8039	71
1	1	-	461264-1	PLATE, IDENTIFICATION	67
2	2	-	21017-2	SCREW, DRIVE	66
1	1	-	986950-1	WASHER, FLAT PRECISION	64
1	1	-	21009-2	SCR, SET, SELF LOCKING 1/4-20 X .250	63
1	1	-	23030-1	SCR, SKT HD CAP 6-32 X .25	62
1	1	-	22733-8	SCR, BHSC, SELF-LOCKING, 8-32 X .375	60
2	2	-	2-21000-8	SCR, SKT HD CAP 8-32 X .625	58
3	3	-	2-21000-6	SCR, SKT HD CAP 8-32 X .375	57
2	2	-	2-21000-7	SCR, SKT HD CAP 8-32 X .500	56
2	2	-	21018-4	NUT, HEX, REG 4-40	54
2	2	-	21022-2	NUT, LOCK, HEX, TORQUE, 8-32	53
2	2	-	2-21006-6	SCR, SET, CUP POINT 4-40 X .625	52
1	1	-	1-21002-7	SCR, BTN SKT CAP 6-32 X .375	49
1	-	-	690501-3	CAM, POST FEED, 1 1/8	48
-	-	-	690501-4	CAM, POST-FEED 1 5/8	47
1	1	-	458980-1	SUB ASSY, APPLICATOR FRAME	46
1	1	-	690191-1	PLUG, NYLON	45
1	1	-	455674-1	RAM	44
1	1	-	690125-1	SHIM SUB-ASSY	43
1	1	-	690124-1	WASHER, RAM (.115)	42
1	1	-	7-21002-9	SCR, BTN SKT HD CAP 5/16-24 X 1.00	41
1	1	-	23241-6	BALL, STEEL	40
1	1	-	690170-1	SPRING, COMPRESSION	39
1	1	-	1-690142-1	DISC, INSULATION	38
1	1	-	354777-1	WIRE DISC, ASSEMBLY	37
1	1	-	22480-5	SPRING, COMPRESSION	36
1	1	-	690212-1	POST, RAM	35
7	7	-	21024-4	WASHER, SPRG LOCK, REG NO 8	32
2	2	-	2-21002-9	SCR, BTN SKT HD CAP 10-32 X .750	31
2	2	-	2-21002-2	SCR, BTN SKT HD CAP 8-32 X .500	29
1	1	-	3-690451-2	SPACER, STRIPPER	28
1	1	-	240639-1	STRIPPER (MACHINING)	27
2	2	-	22354-8	STUD, THREADED	25
1	1	-	455678-1	PLATE, STRIP GUIDE	24
1	1	-	240825-2	PLATE, STRIP HOLD DOWN	23
2	2	-	4-22281-1	SPRING, DRAG	22
1	1	-	454177-1	DRAG	20
2	2	-	2-454204-1	GUIDE, LOWER STRIP	18
4	4	-	3-21002-3	SCR, BTN SKT HD CAP 1/4-20 X .500	17
1	1	-	690481-2	SPACER, HOLD DOWN	13
1	1	-	23846-1	SPRING, DIE	12
1	1	-	240644-1	PLATE, REAR SHEAR	11
-	-	-	-	-	10
1	1	-	690482-5	PLATE, FRONT SHEAR	9
1	1	-	1-1633248-8	ANVIL, COMBINATION	8
1	1	-	690474-5	BLADE, SLUG	7
1	1	-	3-455892-0	HOLD DOWN, TERMINAL	6
1	1	-	7-240641-1	SPACER	5
1	1	-	3-238009-5	BLOCK, FL CRIMPER SPACER	4
1	1	-	1424909-4	CRIMPER, INSULATION F	3
1	1	-	455888-5	SPACER, CRIMPER	2
1	1	-	456405-8	CRIMPER, WIRE PREMIUM	1

DIMENSIONS:		TOLERANCES UNLESS OTHERWISE SPECIFIED:		DRAWN: R. KNEPPER 02NOV2007		TE Connectivity	
INCHES		0 PLC ±.01		CHK: T. ELBIN 04DEC2007		Harrisburg, PA 17105-3608	
1 PLC ±.01		2 PLC ±.001		APVD: W. DEMING 04DEC2007		NAME: END FEED HDM APPLICATOR	
3 PLC ±.001		4 PLC ±.0001		PRODUCT SPEC		APPLICATION SPEC	
ANGLES ±.0001		FINISH		WEIGHT		SIZE: CAGE CODE: DRAWING NO: RESTRICTED TO	
MATERIAL		FINISH		A1 00779		C=1852593	
CUSTOMER ACCESSIBLE PRODUCTION DRAWING				SCALE: 3:5		SHEET 1 OF 1 REV C	