

VIEW Z-Z

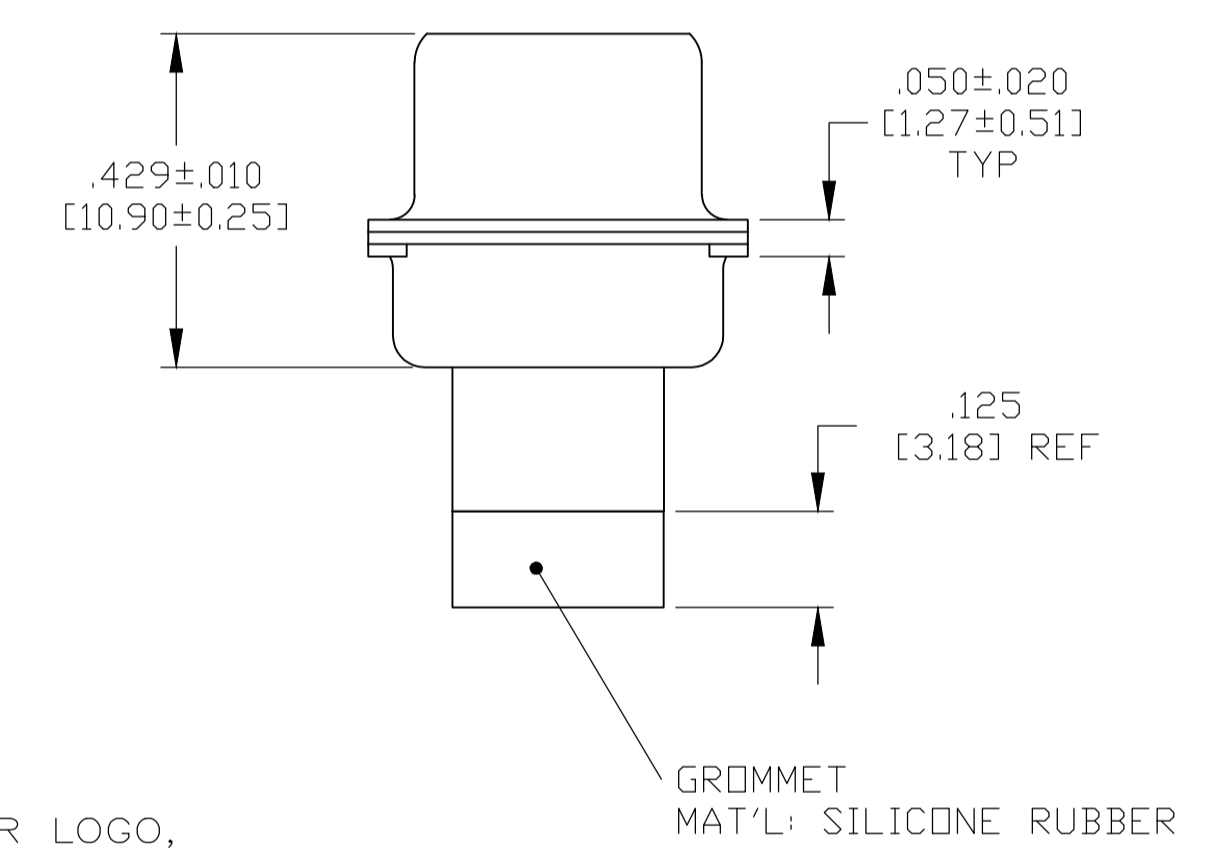
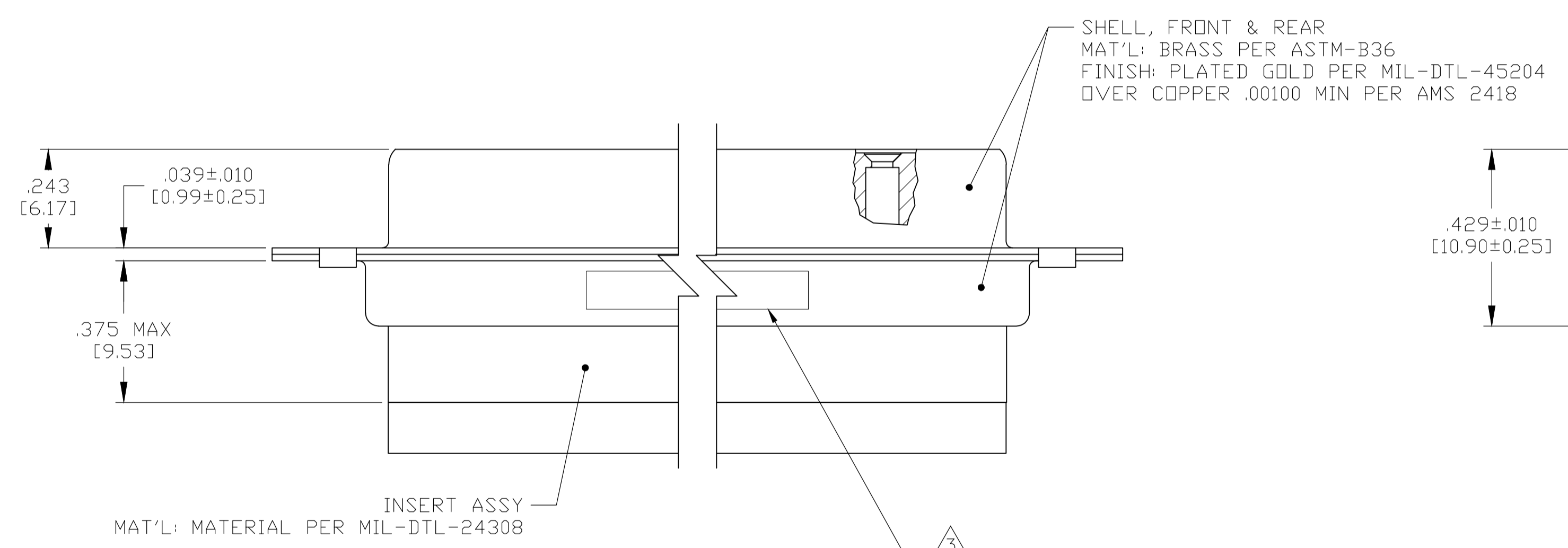

3 MARK MANUFACTURE'S NAME, BRAND OR LOGO, PART NUMBER AND DATE CODE FAR SIDE. CUSTOMER PART NUMBER NEAR SIDE.

- THIS CONNECTOR ASSEMBLY IS SUPPLIED WITH Be Cu CONTACT RETENTION CLIPS INSTALLED IN THE INSERT ASSEMBLY.
- THIS CONNECTOR ASSEMBLY MATES WITH ANY PLUG CONNECTOR WITH THE SAME INSERT ARRANGEMENT AND DIMENSIONAL REQUIREMENTS PER MIL-C-24308.
- MARKED WITH .047 [1.19]-.062 [1.57] HIGH CHARACTERS. FAR SIDE REFERS TO THE WIDE SIDE OF THE KEYSTONE. NEAR SIDE REFERS TO THE NARROW SIDE OF THE KEYSTONE.
- MAXIMUM WIRE INSULATION TO BE USED WITH THIS CONNECTOR ASSEMBLY IS .068 [1.73] DIAMETER.
- SPECIAL REQUIREMENTS PER BOEING 1A01 DOCUMENT.
- BUILT TO ORDER, NO INVENTORY OF THIS PART NUMBER IS TO BE KEPT. SINGLE LOT DATE CODE REQUIRED.

6 7	1A01-024RHW	1-211636-1
--	---	211636-4
6 7	1A01-024RHA	211636-1
REMARKS	CUSTOMER MARKING	PART NUMBER

THIS DRAWING IS A CONTROLLED DOCUMENT.

DIMENSIONS: INCHES [mm]	TOLERANCES UNLESS OTHERWISE SPECIFIED:	DIN MANJUNATH G.M. 28-May-15	CHARLES THOMAS 28-May-15	CHARLES THOMAS 28-May-15
0 PLC ± -	1 PLC ± -	2 PLC ± -	3 PLC ± .005 [0.13]	4 PLC ± -
ANGLES ± ± 1°	APVD: CHARLES THOMAS 28-May-15			
MATERIAL SEE CALLOUTS	FINISH SEE CALLOUTS	WEIGHT	SIZE A1	CAGE CODE 00779
CUSTOMER DRAWING		SCALE 4:1	SHEET 1 OF 1	REV J

STE TE Connectivity
 NAME: RECEPTACLE ASSEMBLY,AMPLIMITE,37 POSITION, SIZE 4,SERIES 109,NON-MAGNETIC
 DRAWING NO: 211636

Mouser Electronics

Authorized Distributor

Click to View Pricing, Inventory, Delivery & Lifecycle Information:

[TE Connectivity:](#)

[1-211636-1](#)