

PART NUMBER	REV	FIRST USED	POWER UNIT	FEED TYPE	DESCRIPTION
1855055-1	A	122500-1	LEADMAKER	POST FEED	CUTS CARRIER
1855055-2	A	565435-5	BENCH MODEL K	PRE FEED	CUTS CARRIER
1855055-3	A	354500-1	BENCH MODEL G	PRE FEED	CUTS CARRIER
1855055-6	A	122500-1	LEADMAKER	POST FEED	CONTINUOUS CARRIER
7-1855055-7	A	-	-	-	SPARE PARTS

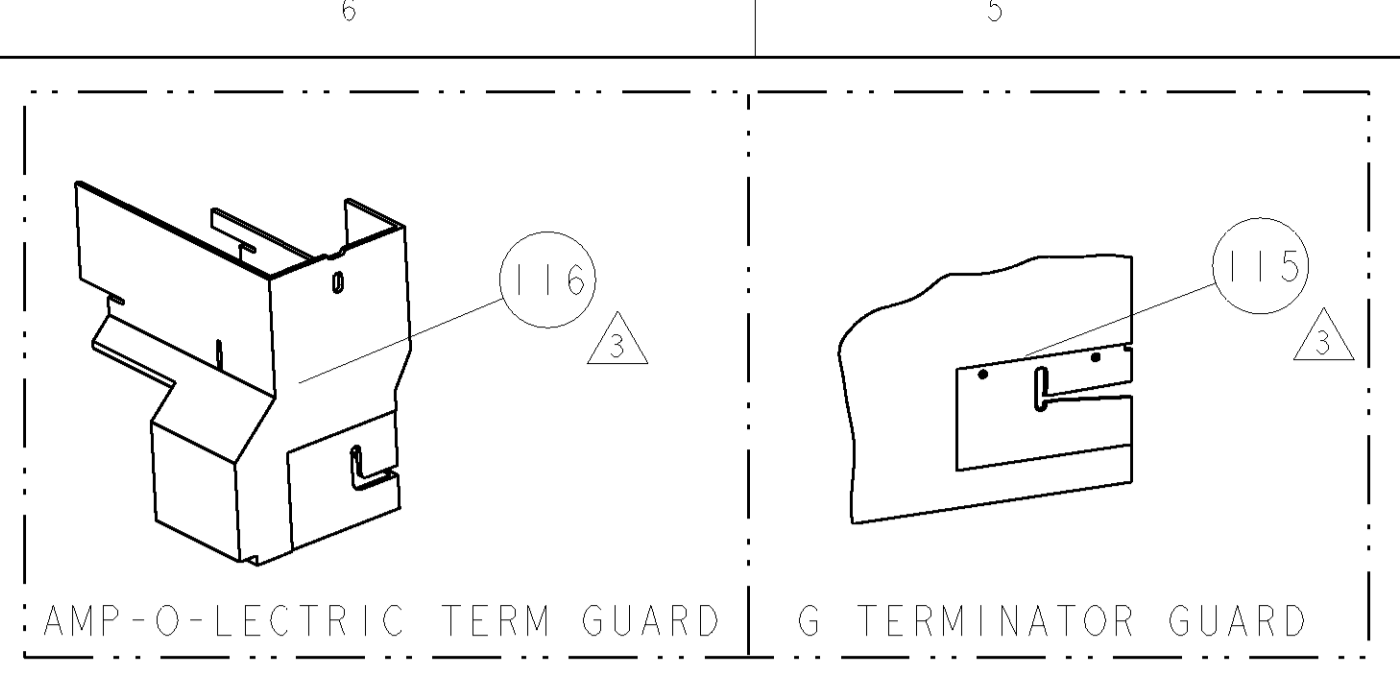

TERMINAL NAME: PIN CONTACT, SIZE 20 DF, 18-22 AWG				
SOCKET	PIN	AMP TERMINAL - AMP CRIMP SPECS		
745230	745229			
		REF SETTING	CRIMP HEIGHT	WIRE SIZE
		B0	.044±.002 [1.12±0.05mm]	18 AWG
		C3	.037±.002 [.94±0.05mm]	20 AWG
		C6	.035±.002 [.89±0.05mm]	22 AWG
		CRIMP	SIZE	TYPE
		WIRE	.062 [1.57mm]	F
		INSUL		
WIRE STRIP LENGTH	TERM APPL SPEC	FEED	APPL INSTRUCTIONS	SET UP GAGE
.099-.119	114-10000	.300	408-8040	458637-1

LOC	DIST	REVISIONS					
A	66	P	LTR	DESCRIPTION	DATE	DWN	APPR
		A		RELEASED	11APR2006	LG	GB

- △ RECOMMENDED SPARE PARTS
- △ GREASE LIGHTLY
- △ GUARD MUST BE IN PLACE WHEN OPERATING APPLICATOR IN A BENCH MACHINE
- △ CUT TO LENGTH AT ASSEMBLY.

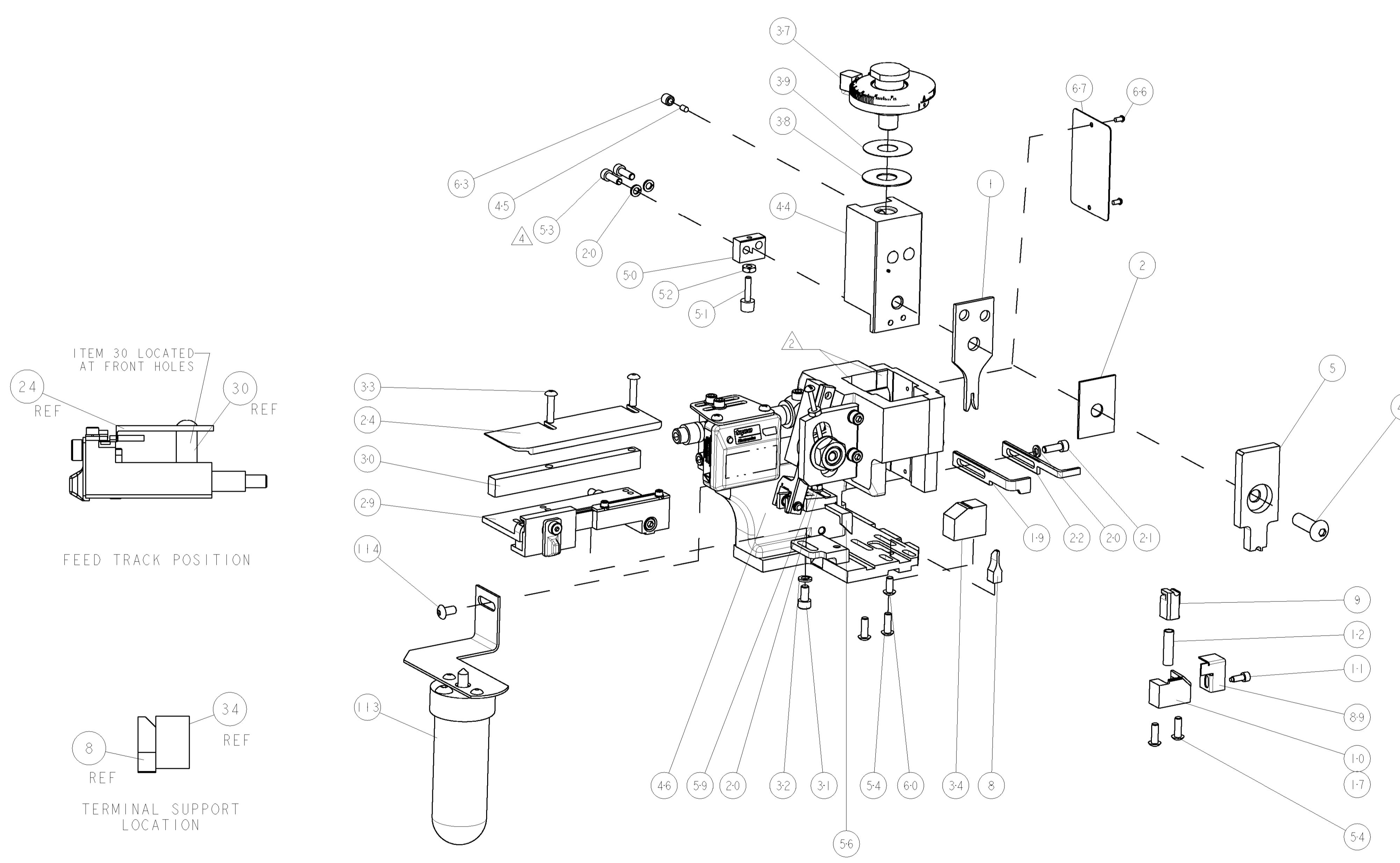

QTY	REF	DESCRIPTION	ITEM NO
1	REF	455749-1 GUARD WINDOW	116
1	REF	679532-1 INSERT, GUARD	115
1	REF	2-21002-6 SCR, BTN SKT HD CAP 10-32 X .375	114
1	REF	1-465184-0 LUBRICATOR ASSY	113
1	REF	1-21002-7 SCR, BTN SKT HD CAP 6-32 X .375	91
1	REF	318563-1 GUARD, FRONT CHIP	89
1	REF	4088040 SF APPL INST 408-8040	72
1	REF	217238-1 GENERAL INSTRUCTION PKG	71
1	REF	461264-5 PLATE, IDENTIFICATION	67
2	2	21017-2 SCREW, DRIVE	66
1	REF	21009-2 SCR, SET, SELF LOCKING 1/4-20 X .250	63
1	REF	22733-8 SCR, BHSC, SELF-LOCKING, 8-32 X .375	60
1	REF	2-22603-0 SCR, HEX HD CAP 8-32 X .312	59
1	REF	458537-2 PAWL, FEED	56
4	4	2-21002-2 SCR, BTN SKT HD CAP 8-32 X .500	54
2	2	2-21000-7 SCR, SKT HD CAP 8-32 X .500	53
1	REF	21018-5 NUT, HEX, REG 6-32	52
1	REF	811242-2 BUMPER, HOLD DOWN	51
1	REF	690753-1 SPACER, TONKER	50
1	REF	690602-6 CAM, PRE FEED, 1 5/8	49
1	REF	690602-5 CAM, PRE FEED, 1 1/8	48
1	REF	690501-4 CAM, POST FEED, 1 5/8	47
1	REF	459456-1 APPL. BASIC SUB ASSY (SIDE WISE MQCA)	46
1	REF	690191-1 PLUG, NYLON	45
1	REF	455673-1 RAM, SIDE FEED	44
1	REF	7-21002-9 SCR, BTN SKT HD CAP 5/16-24 X 1.00	41
1	REF	690125-1 SHIM SUB-ASSY	39
1	REF	469367-8 SHIM	38
1	REF	879103-4 FINE ADJUST HEAD SUBASSY	37
1	REF	692776-1 TERMINAL SUPPORT	34
2	2	2-21002-4 SCR, BTN SKT HD CAP 8-32 X .750	33
1	REF	21024-5 WASHER, SPRG LOCK, REG NO 10	32
1	REF	3-21000-4 SCR, SKT HD CAP 10-32 X .375	31
1	REF	1320908-4 SPACER, STRIP GUIDE	30
1	REF	1633091-1 ASSEMBLY, STRIP GUIDE	29
1	REF	1320928-5 PLATE, STRIP GUIDE	24
1	REF	690472-2 STRIPPER	22
1	REF	2-21000-7 SCR, SKT HD CAP 8-32 X .500	21
4	4	21024-4 WASHER, SPRG LOCK, REG NO 8	20
1	REF	691353-1 STRIPPER	19
1	REF	679625-1 SHEAR HOLDER, FRONT (NO CUT)	17
1	REF	3-22280-3 SPRING, COMPRESSION	12
1	REF	690461-1 STOP, SHEAR	11
1	REF	690459-1 SHEAR HOLDER, FRONT	10
1	REF	462006-1 FLOATING SHEAR, FRONT	9
1	REF	1-683403-6 ANVIL, COMBINATION	8
1	REF	2-455889-0 DEPRESSOR, SHEAR	5
1	REF	1-455888-0 SPACER, CRIMPER	2
1	REF	2-456403-6 CRIMPER, WIRE PREMIUM	1

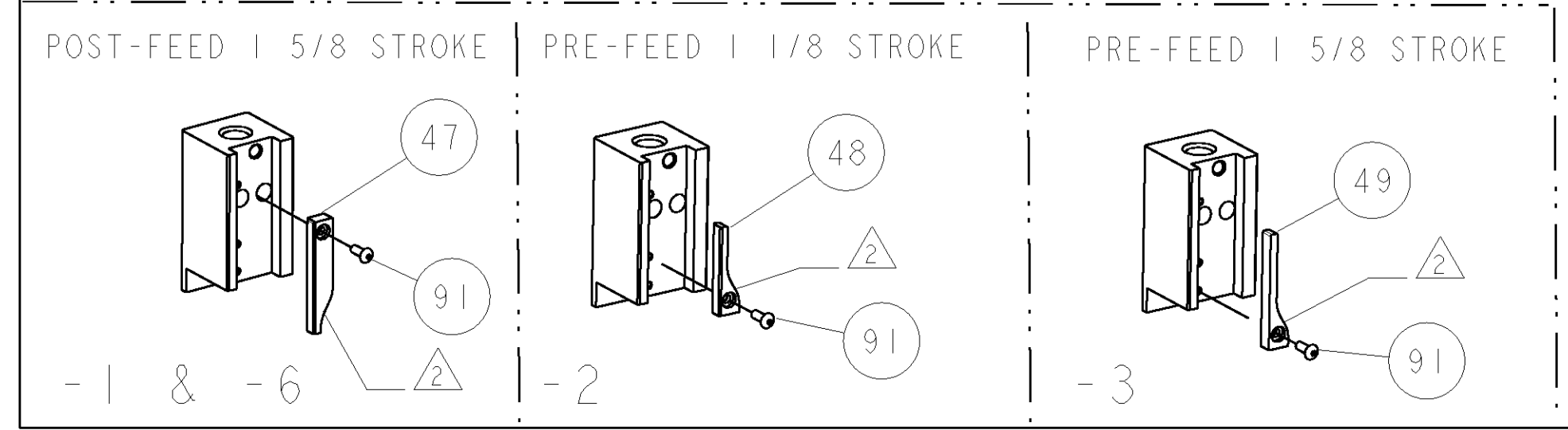

***WARNING:**
ON INSTALLATION, SET WIRE DISC TO LARGEST WIRE SIZE SETTING. USE OF SETTINGS BELOW MIN REQUIRED CRIMP HEIGHT SETTING WILL CAUSE DAMAGE TO CRIMP TOOLING.

DIMENSIONS: INCHES		TOLERANCES UNLESS OTHERWISE SPECIFIED:		DWN: L. GROSS 18MAR2006		C. REICHELDERFER 18MAR2006		G. BAILEY 18MAR2006		Tyco Electronics Harrisburg, PA 17105-3608	
0 PLC	±	1 PLC	±0.1	PRODUCT SPEC		NAME		SIZE		RESTRICTED TO	
1 PLC	±0.1	2 PLC	±0.01	APPLICATION SPEC		CAGE CODE		DRAWING NO		SHEET 1 OF 1	
3 PLC	±0.001	4 PLC	±0.0001	MATERIAL		WEIGHT		SCALE		REV	
MATERIAL		FINISH		CUSTOMER DRAWING		A11 00779		C=1855055		REV A	

CUSTOMER VIEWABLE ASSEMBLY

Mouser Electronics

Authorized Distributor

Click to View Pricing, Inventory, Delivery & Lifecycle Information:

[TE Connectivity:](#)

[1855055-2](#)