

SECTION A-A
CONDUCTOR WINGS

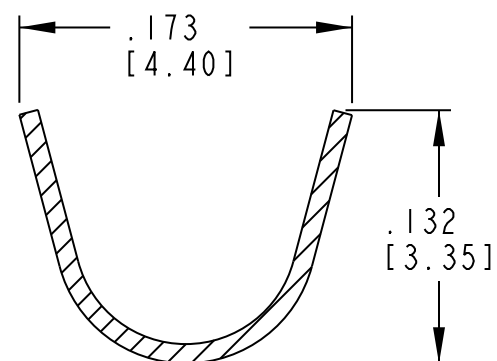

SECTION B-B
INSULATION WINGS

REV
E 1060-20-01 * *

REVISIONS			
SYM	DESCRIPTION	DATE	APPROVED
B	REVISED PER E.O. P17913	11-1-02	R.D.R.
C	REVISED PER E.O. P18438	12-19-03	R.D.R.
D	REVISED PER E.O. P20044	11-3-08	R.D.R.
E	REVISED PER E.O. P20392	12-3-09	R.D.R.

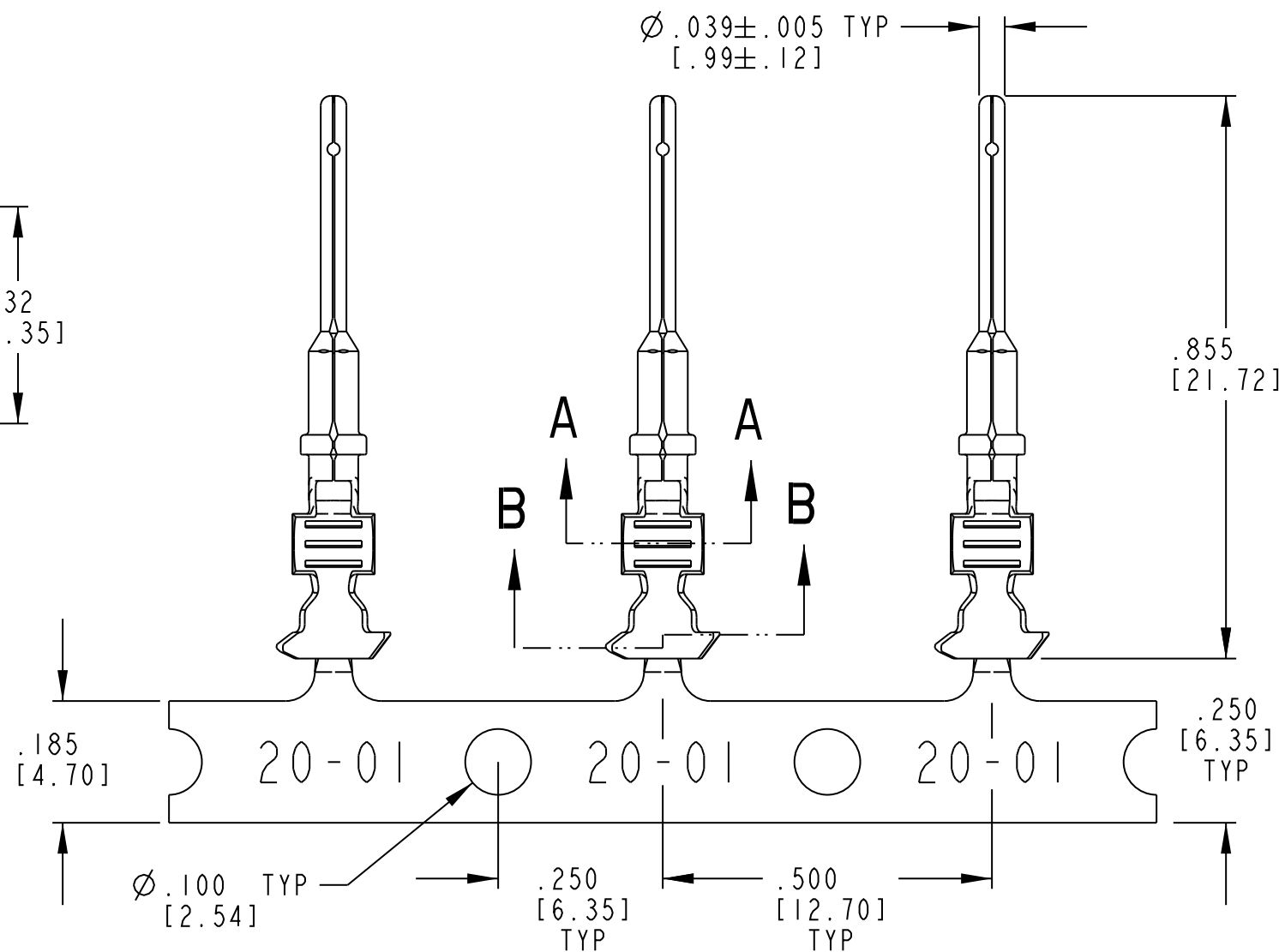

7. MATERIAL: COPPER ALLOY.
6. WHEN ** = 22 PLATING IS NICKEL.
 ** = 44 PLATING IS GOLD.
 ** = 77 PLATING IS TIN.
5. SEE 0425-015-0000 FOR CONTACT PERFORMANCE AND WIRE APPLICATION CHARACTERISTICS.
4. THIS CONTACT MAY BE CRIMPED WITH DCT20-02-00 AUTOMATIC DIE OR DTT-20-00 HAND TOOL. SEE DRAWING 0425-207-0000 FOR APPLICABLE WIRE SIZE, INSULATION DIAMETER RANGE, AND CRIMPING INFORMATION.
3. ONE REEL CONTAINS APPROXIMATELY 4000 CONTACTS.
2. DIMENSIONAL TOLERANCE: ±.025 [0.63].
1. DIMENSIONS ARE IN INCHES [mm].

NOTES: UNLESS OTHERWISE SPECIFIED

SIGNATURE & DATE	
DR	J. APOSTOL 01DEC2009
CHK	D. MEYER 12/2/09
PE	D. MEYER 12/2/09
APPD	R. REED 12-3-09
SCALE	NONE WT _____

STAMPED CONTACT
PIN
SIZE 20

ENVELOPE

EP	MATL. CODE
3850 INDUSTRIAL AVE. HEMET, CA 92545	
B 1060-20-01 * *	
DWG SIZE	CODE 11139 SHEET OF