

NUMBER GS-12-0943	TYPE PRODUCT SPECIFICATION		
TITLE External CXP Cable Assembly		PAGE 1 of 16	REVISION B
		AUTHORIZED BY D.Dillow	DATE 3-06-2013
		CLASSIFICATION UNRESTRICTED	

1.0 SCOPE

2.0 PRODUCT DESCRIPTION

- 2.1 Product Name and Series Number(s)
- 2.2 Dimensions, Materials, Plating and Markings
- 2.3 Additional General Specifications
- 2.4 Safety Agency Approvals

3.0 REFERENCE DOCUMENTS

- 3.1 FCI Documents
- 3.2 Industrial Documents

4.0 QUALIFICATION

5.0 RATINGS

- 5.1 Voltage
- 5.2 Current
- 5.3 Temperature

6.0 PERFORMANCE

- 6.1 Electrical Characteristics
- 6.2 ESD Requirements
- 6.3 EMI Protection
- 6.4 CXP Pin Assignment
- 6.5 2 Wire Interface EEPROM
- 6.6 Mechanical Characteristics
- 6.7 Environmental Requirements

7.0 QUALITY ASSURANCE PROVISIONS

- 7.1 Equipment Calibration
- 7.2 Inspection Conditions
- 7.3 Sample Quantity and Description
- 7.4 Acceptance
- 7.5 Qualification Testing
- 7.6 Requalification Testing

8.0 SUPPORTING INFORMATION

9.0 REVISION RECORD

NUMBER GS-12-0943	TYPE PRODUCT SPECIFICATION		
TITLE External CXP Cable Assembly		PAGE 2 of 16	REVISION B
		AUTHORIZED BY D.Dillow	DATE 3-06-2013
		CLASSIFICATION UNRESTRICTED	

1.0 SCOPE

This specification is applicable to the performance characteristics of CXP cable assembly.

2.0 PRODUCT DESCRIPTION

2.1 PRODUCT NAME AND SERIES NUMBER(S)

Product	Series P/N	Test Sections Do Not Apply
10G CXP Cable Assembly	10116951	
14G CXP Cable Assembly	10120706	

2.2 DIMENSIONS, MATERIALS, PLATING AND MARKINGS

Refer to the applicable customer drawing for the related dimensional, material, plating, and marking information.

2.3 ADDITIONAL GENERAL SPECIFICATIONS

Plug PCB:

- Material: FR4 for Standard Cable Assembly
- Material: HE679G for 14G Cable Assembly
- Overall thickness: 1.0mm ±0.1(over pads)
- Mating interface plating: Hard gold over nickel

Bulk Cable:

- As listed on the cable specification drawings.

2.4 SAFETY AGENCY APPROVALS

- UL File Number E70424

NUMBER GS-12-0943	TYPE PRODUCT SPECIFICATION		
TITLE External CXP Cable Assembly		PAGE 3 of 16	REVISION B
		AUTHORIZED BY D.Dillow	DATE 3-06-2013
		CLASSIFICATION UNRESTRICTED	

3.0 REFERENCE DOCUMENTS

3.1 FCI DOCUMENTS

GS-14-1272 Cable Assembly Packaging Specification
SI-2012-03-21 CXP Signal Integrity Performance Report (This Applies Only To 10G P/N)
SI-VG-2012-11-018 14G CXP Signal Integrity Performance Report (This Applies Only To 14G P/N)
Contech Research report 212741 Rev.1.1 CXP 10G Product Qualification Report
EL-2013-01-006 CXP 14G Product Qualification Report

3.2 INDUSTRY DOCUMENTS

FIT, FORM AND FUNCTION

SFF-8410 HSS Copper Testing and Performance Requirements
SFF-8642 Mini Multilane Series: Shielded Integrated Connector
SFF-8095 Tether Testing Procedure
IEEE 802.3 Gigabit Ethernet Standard
ITU-T G.957 Synchronous Digital Hierarchy Standard
Telcordia Technologies GR-253-CORE
JEDEC JESD22-A-114B ESD Specification
InfiniBand Architecture Specification Volume 2, Release 1.2.1, Annex A6
Infiniband IBTA FDR (022912a) Fourteen Data Rate (This is for reference only to the 14G QSFP+ P/N)

TEST SPECIFICATON(S)

EIA 364 Series Electrical Connector Test Procedures Including Environmental Classifications with Test Procedure

4.0 QUALIFICATION

Connector and cable assemblies furnished under this specification shall be capable of meeting the qualification test requirements specified herein and shall be uniform in quality, and void of all defects that would adversely affect life or serviceability.

NUMBER GS-12-0943	TYPE PRODUCT SPECIFICATION		
TITLE External CXP Cable Assembly		PAGE 4 of 16	REVISION B
		AUTHORIZED BY D.Dillow	DATE 3-06-2013
CLASSIFICATION UNRESTRICTED			

5.0 RATINGS

5.1 VOLTAGE

30 Volts AC per Contact (RMS)/DC Max.

5.2 CURRENT

0.5 Amps Max. All contacts simultaneously
1 Amp Max per single contact only.

5.3 TEMPERATURE

Operating: -20°C to +85°C
Non-operating: -55°C to + 85°C

5.4 FLAMMABILITY

Bulk Cable – UL-CL2 / CSA FT4
Cable and Board Connector – All Materials UL 94 V-0

6.0 PERFORMANCE

6.1 ELECTRICAL CHARACTERISTICS

ITEM	DESCRIPTION	TEST CONDITION	REQUIREMENT
6.1.1	LLCR	Mate connectors: apply a maximum voltage of 20 mV and a current of 100 mA. (EIA 364-23)	20 milliohm maximum change from initial after environmental exposure
6.1.2	Insulation Resistance	Measure the insulation resistance at 100 VDC for 1 minute between adjacent mated signal contacts. (EIA 364-21)	1000 MΩ Minimum between adjacent contacts
6.1.3	Dielectric Withstanding Voltage	Apply a voltage of 300 VDC for 1 minute between adjacent mated signal terminals. (EIA 364-20, method B, condition 1)	No arcing or leakage current greater than 5 mA
6.1.4	Temperature Rise (via Current Cycling)	Mate connectors: Measure the temperature rise with the rated current applied through all signal contacts after 96 hours of current cycling (45 minutes ON and 15 minutes OFF). Measure the temperature rise with the rated current applied through a single contact. (EIA 364-70 or IEC-512-5-1 test 5a) (Testing as required)	Temperature rise: +30°C MAX.
6.1.5	Differential Impedance	Rise time of 70ps (20% to 80%) (EIA 364-108)	100 +/- 10 ohms

NUMBER GS-12-0943	TYPE PRODUCT SPECIFICATION		
TITLE External CXP Cable Assembly		PAGE 5 of 16	REVISION B
		AUTHORIZED BY D.Dillow	DATE 3-06-2013
		CLASSIFICATION UNRESTRICTED	

6.2 ESD Requirements

The module shall meet ESD requirements given in EN61000-4-2, criterion B test specification such that when installed in a properly grounded cage and chassis the units are subjected to 15KV air discharges during operation and 8KV direct contact discharges to the case.

The CXP module and host SFI contacts (High Speed Contacts) shall withstand 1000V electrostatic discharge based on human body model per JEDEC JESD22-A114-B.

The CXP module and host SFI contacts with the exception of the SFI contacts (High Speed Contacts) shall withstand 2kV electrostatic discharge based on human body model per JEDEC JESD22-A114-B.

The CXP module shall meet ESD requirements given in EN61000-4-2, criterion B test specification such that units are subjected to 15kV air discharges during operation and 8kV direct contact discharges to the case.

6.3 EMI Protection

The chassis ground of the CXP module is isolated from the modules circuit ground to provide the equipment designer flexibility regarding connections between external electromagnetic interference shields and circuit ground of the module.

6.4 Module Contact Pin Define & Module Mechanical Requirements

The CXP cable assembly pin assignment (Figure 3) per specification InfiniBand, Volume 2, Revision 1.2.1, Annex A6. The module mechanical shall meet the requirements of SFF-8642 Specification.

NUMBER GS-12-0943	TYPE PRODUCT SPECIFICATION		
TITLE External CXP Cable Assembly		PAGE 6 of 16	REVISION B
		AUTHORIZED BY D.Dillow	DATE 3-06-2013
CLASSIFICATION UNRESTRICTED			

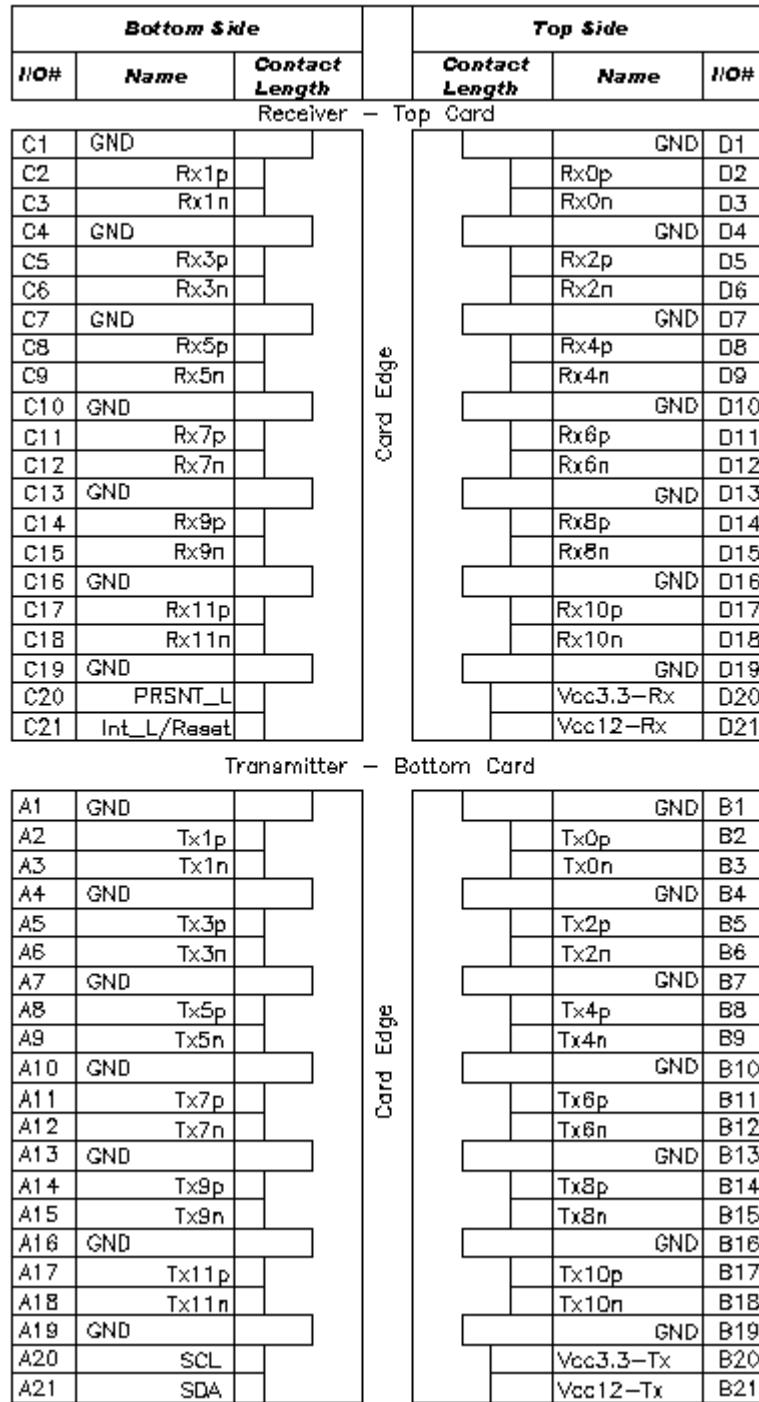



FIGURE 3
CXP Module Contact Definition

NUMBER GS-12-0943	TYPE PRODUCT SPECIFICATION		
TITLE External CXP Cable Assembly		PAGE 7 of 16	REVISION B
		AUTHORIZED BY D.Dillow	DATE 3-06-2013
		CLASSIFICATION UNRESTRICTED	

6.5 2 Wire Interface EEPROM

The CXP serial ID provides access to sophisticated identification information that describes the Transceiver's capabilities, standard interfaces, manufacturer, and other information. The EEPROM on the CXP cable assembly is designed for 255 addresses. The information for addresses will be programmed in accordance with InfiniBand Specification Volume 2, Release 1.2.1, Annex A6 and /or customers' specification.

6.6 MECHANICAL CHARACTERISTICS

This cable assembly was designed for compliance with the SFF-8642.

ITEM	DESCRIPTION	TEST CONDITION	REQUIREMENT
6.6.1	Durability (Pre-Conditioning)	EIA-364-09, Perform plug & un-plug cycles 50 times with latch disengaged.	1. No evidence on physical damage.
6.6.2	Durability	Cable Assembly: 250 Cycles with latch disengaged. (EIA 364-09)	1. Max. 20 milliohm change from initial readings 2. No visual damage
6.6.3	Mechanical Shock	Mated samples subject to 30G, half-sine shock pulses of 11 milliseconds duration. 3 shocks in each direction applied in 3 mutually perpendicular planes (18 total). EIA 364-27, condition H	1. No Physical Damage 2. 20mOhms maximum change from initial contact resistance.
6.6.4	Vibration	Mate samples subjected to 3.10G RMS between 20 and 500 Hz for 15 minutes in each of 3 mutually perpendicular planes EIA 364-28, Test Condition: VII D. Both mating halves of samples are to be rigidly mounted.	1. Max. 20 milliohm change from initial contact resistance 2. No visual damage 3. No discontinuances greater than 1 microsecond
6.6.5	Mating / Un-mating Force	With latch disengaged Test per EIA 364-13, method A	150 N Max. Mating 50 N Max. Un-mating
6.6.6	Cable Strain Relief	Hold plug. Place axial load on cable. Test Condition: 25mm/min head speed (EIA 364-38A)	1. 90N Min / 170 N Max. 2. No physical damage. 3. Differential Impedance 100 ± 10Ω

NUMBER GS-12-0943	TYPE PRODUCT SPECIFICATION		
TITLE External CXP Cable Assembly		PAGE 8 of 16	REVISION B
		AUTHORIZED BY D.Dillow	DATE 3-06-2013
		CLASSIFICATION UNRESTRICTED	

6.6.7	Wire Flex	Cable flex 180° - 15 Cycles Test Condition : See Table 1 and Figure 2 (EIA 364-41)	<ol style="list-style-type: none"> Differential Impedance 100 ± 10Ω No physical damage. No loss of continuity during test.
6.6.8	Cable Minimum Bend Radius	The cable is bent one time over the correct mandrel of size specified in Table 1 in each of 4 perpendicular directions. (Figure 1)	<ol style="list-style-type: none"> Differential Impedance 100 ± 10Ω No physical damage.
6.6.9	Latch Retention Strength	Mate connectors (cable plug, board connector, and cage) and place an axial load on the cable connector. Test Condition: Displacement rate of 25mm/min	<ol style="list-style-type: none"> 180N Maximum No physical damage to the latch below 180N 89N Minimum

Raw Cable AWG 24 Pair Standard	Minimum Bending Radius Repeated	Minimum Bending Radius Single
30AWG	4.0" (101.6mm)	2.0" (50.8mm)
26AWG	5.0" (127mm)	2.5" (63.5mm)
28AWG	4.5" (114.3)	2.25" (57.15mm)

* Minimum Bend Radius for all CXP cables will use the following formula:
 Repeated Bending = 10 X Cable Diameter and Single Bending = 5 X Cable Diameter

Table 1 – Cable Minimum Bend Radius (See Figure 1 & 2)

NUMBER GS-12-0943	TYPE PRODUCT SPECIFICATION		
TITLE External CXP Cable Assembly		PAGE 9 of 16	REVISION B
		AUTHORIZED BY D.Dillow	DATE 3-06-2013
CLASSIFICATION UNRESTRICTED			

6.7 ENVIRONMENTAL REQUIREMENTS

ITEM	DESCRIPTION	TEST CONDITION	REQUIREMENT
6.7.1	Thermal Shock	Test Condition: 10 cycles -55°C to +85°C. (EIA 364-32, method A, condition I, test duration A-4)	20 milliohm maximum change from initial readings
6.7.2	Temperature Life	Cable should be mated and subject 85°C (EIA 364-17, method A, condition 3) for 500 hours Time Condition C	20 milliohm maximum change from initial readings
6.7.3	Humidity Temperature Cycling	Cables unmated specimens to 10 cycles (10 days) between 25°C and 65°C at 80% to 100% relative humidity EIA 364-31, Method III excluding steps 7a & 7b	20 milliohm maximum change from initial readings
6.7.4	Mixed Flowing Gas	Subject the board mounted receptacle to environmental Class IIA for 7 days unmated followed by 7 days mated (14 days total) EIA 364-65, Class IIA	No damage 20 milliohm maximum change from initial readings
6.7.5	Thermal Disturbance	Cables are cycled between 15±3 and 85±3°C as measured on the part. Ramps at min 2°C/minute and dwells ensuring contacts reach extremes for 5 minutes minimum. Humidity not controlled. Perform 10 such cycles. EIA 364-32	20 milliohm maximum change from initial readings

7.0 QUALITY ASSURANCE PROVISIONS

7.1 Equipment Calibration

All test equipment and inspection facilities used in the performance of any test shall be maintained in a calibration system in accordance with MIL-C-45662.

7.2 Inspection Conditions

Unless otherwise specified herein, all inspections shall be performed under the following ambient conditions:

- a. Temperature: 25 +/- 5 degrees Celsius
- b. Barometric Pressure: Local ambient

NUMBER GS-12-0943	TYPE PRODUCT SPECIFICATION		
TITLE External CXP Cable Assembly		PAGE 10 of 16	REVISION B
		AUTHORIZED BY D.Dillow	DATE 3-06-2013
		CLASSIFICATION UNRESTRICTED	

7.3 Sample Quantity And Description

Test Group	Number of Cables	Cable Description	Number of Board Connectors
1	3	Each AWG, double ended, 1 meter	2
2	3	Any AWG, single ended, 0.5 meter	3
3	6	Any AWG, single ended, 0.5 meter	3 Board Connectors and 3 Loose Piece connectors
4	3	30 AWG, single ended, 0.5 meter	3
5	3	Any AWG, single ended, 0.5 meter	3
6	3	Small AWG, single ended, 0.5 meter	3
	3	Large AWG, single ended, 0.5 meter	3

For qualification test samples, DC blocking capacitors on the receive channels are to be replaced by 0 ohm resistors so that LLCR measurements can be taken on the receive channels.

NUMBER GS-12-0943	TYPE PRODUCT SPECIFICATION		
TITLE External CXP Cable Assembly		PAGE 11 of 16	REVISION B
		AUTHORIZED BY D.Dillow	DATE 3-06-2013
		CLASSIFICATION UNRESTRICTED	

7.4 Acceptance

- 7.4.1 Electrical and mechanical requirements placed on test samples as indicated in section 6.0 shall be established from test data using appropriate statistical techniques. All samples tested in accordance with this product specification shall meet the stated requirements.
- 7.4.2 Failures attributed to equipment, test set-up, or operator error shall not disqualify the product. If product failure occurs, corrective action shall be taken and samples resubmitted for qualification.

7.5 Qualification Testing

Qualification testing shall be performed on sample units produced with equipment and procedures normally used in production. The test sequence shall be as shown in Table 2.

7.6 Requalification Testing

If any of the following conditions occur, the responsible product engineer shall initiate requalification testing consisting of all applicable parts of the qualification test matrix, Table 2.

- a. A significant design change is made to the existing product, which impacts the product form, fit or function.
- b. A significant change is made to the manufacturing process, which impacts the product form, fit or function.
- c. A significant event occurs during production or end use requiring corrective action to be taken relative to the product design or manufacturing process.



NUMBER GS-12-0943	TYPE PRODUCT SPECIFICATION		
TITLE External CXP Cable Assembly		PAGE 12 of 16	REVISION B
		AUTHORIZED BY D.Dillow	DATE 3-06-2013
		CLASSIFICATION UNRESTRICTED	

TABLE 2 - QUALIFICATION TESTING MATRIX

TEST	PARA.						
		1	2	3	4	5	6
Examination of Product		1,9	1,3	1,12	1,6	1,14	1,11
LLCR	6.1.1			2,6,8	2,4	2,5,7,9,1 1,13	2,5,7,9
Insulation Resistance (IR)	6.1.2			3,9			
Dielectric Withstanding Voltage (DWV)	6.1.3			4,10			
Differential Impedance	6.1.5	2,4,6,8					
Durability Pre-Condition	6.6.1					4	
Durability	6.6.2						4
Mechanical Shock	6.6.3						6
Vibration	6.6.4						8
Mating/Un-mating Force	6.6.5					3,12	3,10
Cable Strain Relief	6.6.6	7			5		
Wire Flex	6.6.7	5					
Minimum Bend Radius	6.6.8	3					
Latch Retention Strength	6.6.9		2				
Thermal Shock	6.7.1			5			
Temperature Life	6.7.2				3		
Humidity Temperate Cycling	6.7.3			7			
Mixed Flowing Gas	6.7.4					6,8	
Thermal Disturbance	6.7.5					10	

NUMBER GS-12-0943	TYPE PRODUCT SPECIFICATION		
TITLE External CXP Cable Assembly		PAGE 13 of 16	REVISION B
		AUTHORIZED BY D.Dillow	DATE 3-06-2013
		CLASSIFICATION UNRESTRICTED	

8.0 SUPPORTING INFORMATION

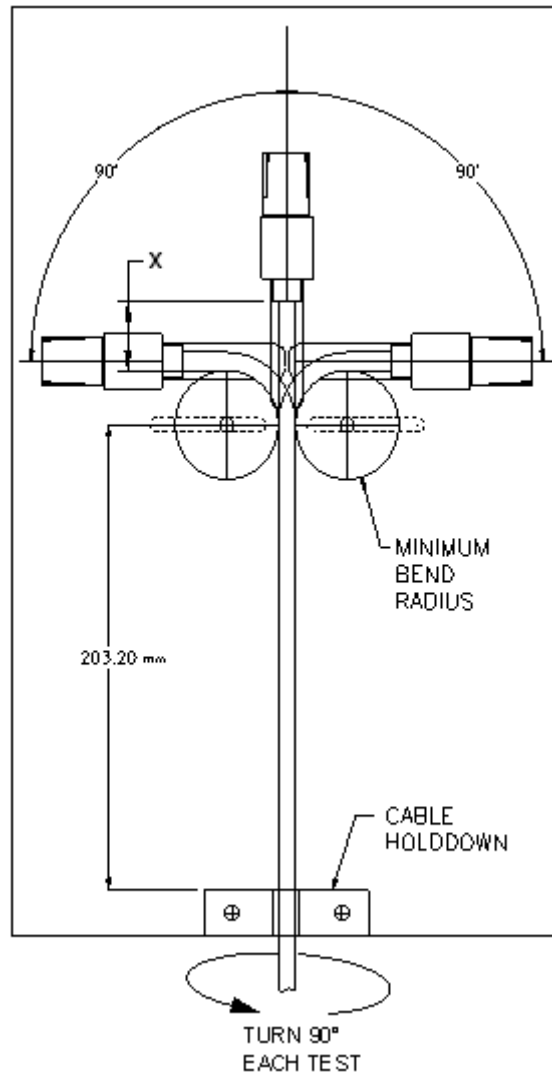



Figure 1 – Single Minimum Bending Radius.
Dimension “X” will vary with different minimum bend
Radius required by various cables.
(See Mechanical Characteristics 6.6.8 and Table 1)

NUMBER GS-12-0943	TYPE PRODUCT SPECIFICATION		
TITLE External CXP Cable Assembly		PAGE 14 of 16	REVISION B
		AUTHORIZED BY D.Dillow	DATE 3-06-2013
		CLASSIFICATION UNRESTRICTED	

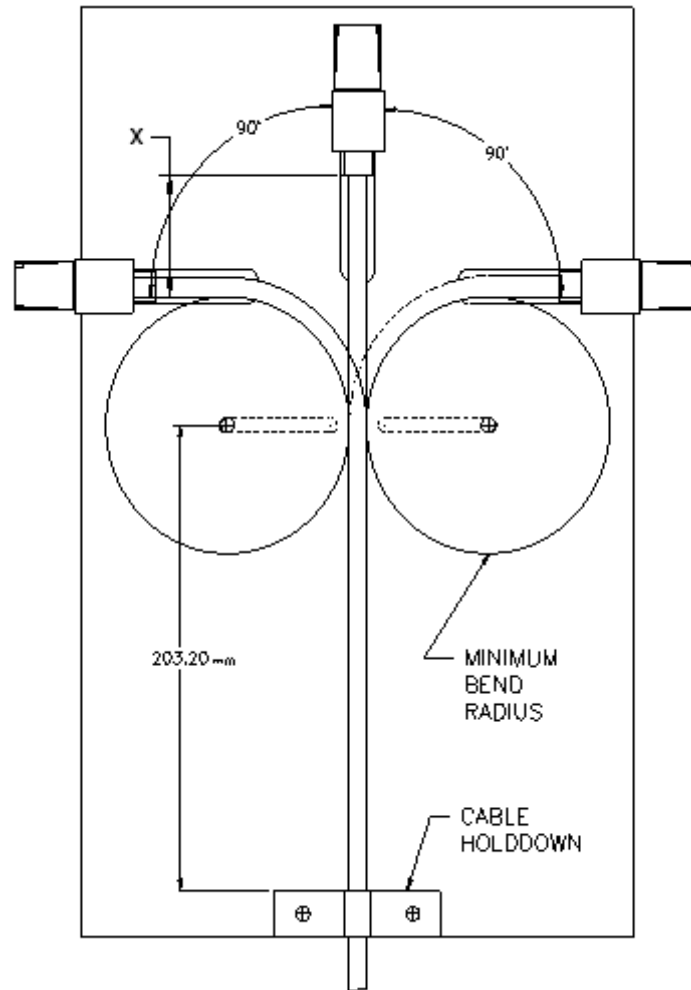



Figure 2 – Repeated Wire Flex Test
Dimension “X” will vary with different minimum bend radius required by various cables.
(See Mechanical Characteristics 6.6.7 and Table 1)

The distance X from the rear of the plug connector assembly to the top of the mandrel as listed below:

Table 3

Raw Cable Size	For Single Bend	Multiple Bend
30AWG	38 mm	67 mm
26AWG	47 mm	83 mm
28AWG	42 mm	75 mm

NUMBER GS-12-0943	TYPE PRODUCT SPECIFICATION		
TITLE External CXP Cable Assembly		PAGE 15 of 16	REVISION B
		AUTHORIZED BY D.Dillow	DATE 3-06-2013
CLASSIFICATION UNRESTRICTED			

9.0 REVISION RECORD

REV.	PAGE	DESCRIPTION	ECR	DATE
A	All	Initial Release		3/06/13
B	2,3	Add 14G cable assembly P/N; Correct 10G & 14G Product Qualification report number	ECR-ELX-N-15511	8/19/13

Mouser Electronics

Authorized Distributor

Click to View Pricing, Inventory, Delivery & Lifecycle Information:

[FCI / Amphenol:](#)

[10116951-2010LF](#) [10120706-2015HLF](#) [10120706-2020LF](#) [10120706-3020HLF](#) [10120706-3020LF](#) [10120706-3030HLF](#) [10120706-2005HLF](#) [10120706-3010HLF](#) [10120706-2010LF](#) [10120706-3010LF](#) [10120706-3025LF](#) [10120706-2020HLF](#) [10120706-3025HLF](#) [10120706-3015LF](#) [10120706-2010HLF](#) [10120706-3015HLF](#) [10120706-2015LF](#) [10120706-3030LF](#) [10120706-3005HLF](#) [10120706-2005LF](#) [10116951-2005HLF](#) [10116951-4040HLF](#) [10116951-2020HLF](#) [10116951-4005HLF](#) [10116951-4010HLF](#) [10116951-4042LF](#) [10116951-2025LF](#) [10116951-4030HLF](#) [10116951-4020HLF](#) [10116951-4015HLF](#) [10116951-4042HLF](#) [10116951-4025HLF](#) [10116951-4035HLF](#) [10116951-2025HLF](#) [10116951-2010HLF](#) [10116951-2015HLF](#) [10116951-2015LF](#) [10120706-3005LF](#) [10116951-4020LF](#) [10116951-4025LF](#) [10116951-4030LF](#) [10116951-4005LF](#) [10116951-2020LF](#) [10116951-4015LF](#) [10116951-4010LF](#) [10116951-4035LF](#) [10116951-2005LF](#) [10116951-4040LF](#)