

10 9 8 7 6 5 4 3 2 1

THIS DESIGN IS BASED ON DESIGN OBJECTIVES AND IS STRICTLY TENTATIVE. IT MAY CHANGE BASED ON RESULTS OF ADDITIONAL DESIGN REVIEWS & VERIFICATIONS.

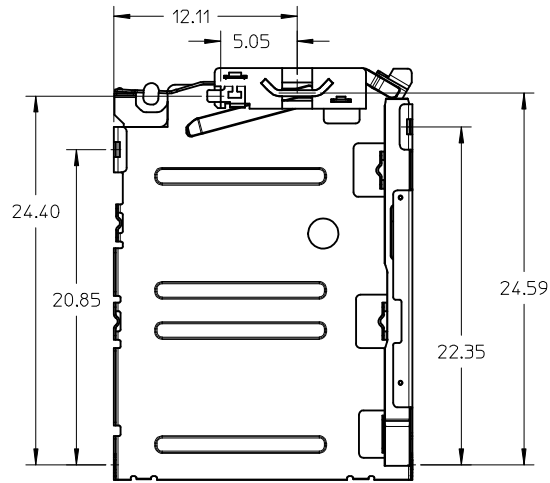
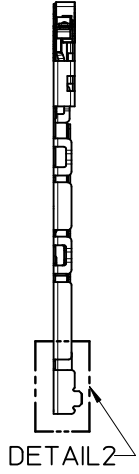
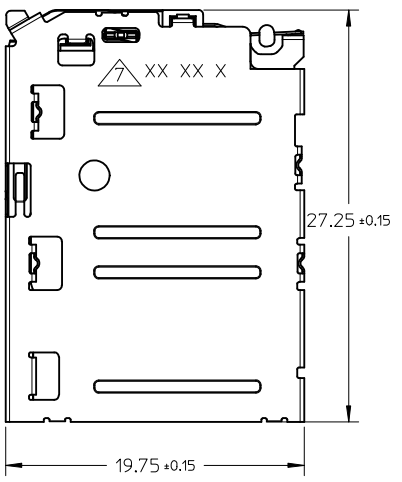
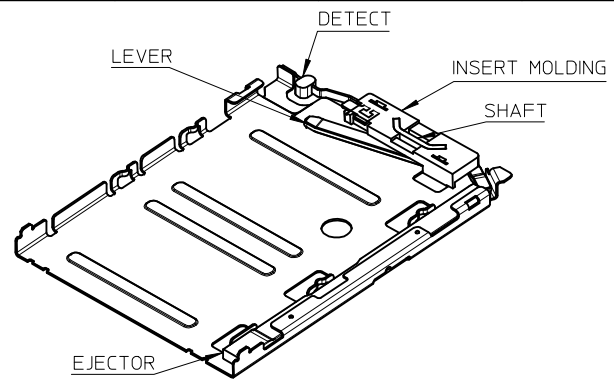
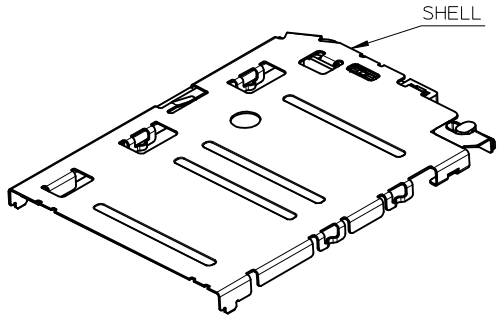

NOTES:

1. MATERIALS:
 INSERT MOLD HOUSING: LCP, UL94V-0;
 LEVER, SHAFT, EJECTOR, SHELL: STAINLESS STEEL;
 DETECT SPRING: COPPER ALLOY;
 2. FINISHES:
 DETECT SPRING:
 1.27um MIN. NICKEL UNDERPLATING OVERALL;
 0.127um MIN. GOLD PLATING ON CONTACT AREA;
 1.27 um MIN. TIN PLATING ON SOLDERING TAIL;
 SHELL:
 1.27um MIN NICKEL UNDERPLATING OVERALL;
 0.025um MIN GOLD PLATING ON CONTACT AREA AND SOLDERING AREA;
 SHAFT: 1.27um MIN TIN ON SOLDERING TAIL;
 3. PRODUCT SPECIFICATION: PS-151031-0001;
 4. PACKAGING SPECIFICATION: PK-151031-0002, PK-151032-0001
 5. SOLDER TAIL COPLANARITY: 0.10 MM MAX BEFORE REFLOW
 6. THIS PART IS A FRAME ONLY, IT SHOULD BE USED TOGETHER WITH 0.35MM BLOCK SIM 151032 FOR AN ENTIRE SIM POP OUT SYSTEM;
- △ DATE CODE PRINTED: XX XX X

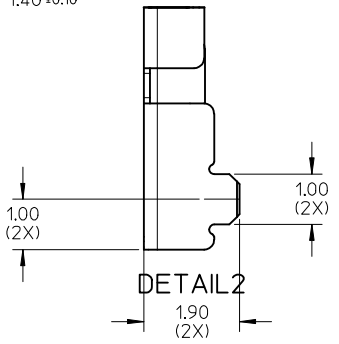
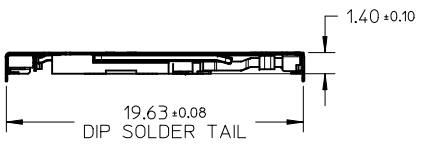

UPDATED DRAWING EC NO: S2015-0559 DRWN: JZENG 2014/11/26 CHKD: JTAN02 2014/12/22 APPR: KHL IM 2014/12/24	QUALITY SYMBOLS $F_A=0$ $F_G=4$ $F_P=0$	GENERAL TOLERANCES (UNLESS SPECIFIED)		DIMENSION STYLE MM ONLY	SCALE NTS	DESIGN UNITS METRIC	THIRD ANGLE PROJECTION	
		mm	INCH	DRAWN BY JZENG	DATE 2013/12/13	TITLE DUAL MICRO SIM FRAME 1.40H		
		4 PLACES ± --- ± ---	3 PLACES ± --- ± ---	CHECKED BY KHL IM	DATE 2014/01/27	MATERIAL NO. 1510313001		
		2 PLACES ± 0.20 ± ---	1 PLACE ± 0.20 ± ---	APPROVED BY KHL IM		DOCUMENT NO. SD-151031-0002		
0 PLACE ± --- ± ---		ANGULAR ± 3 °		SHEET NO. 1 OF 5		THIS DRAWING CONTAINS INFORMATION THAT IS PROPRIETARY TO MOLEX INCORPORATED AND SHOULD NOT BE USED WITHOUT WRITTEN PERMISSION		

9 8 7 6 5 4 3 2 1

SIM CONNECTOR
(WITH 151032 BLOCK SIM CONNECTOR)

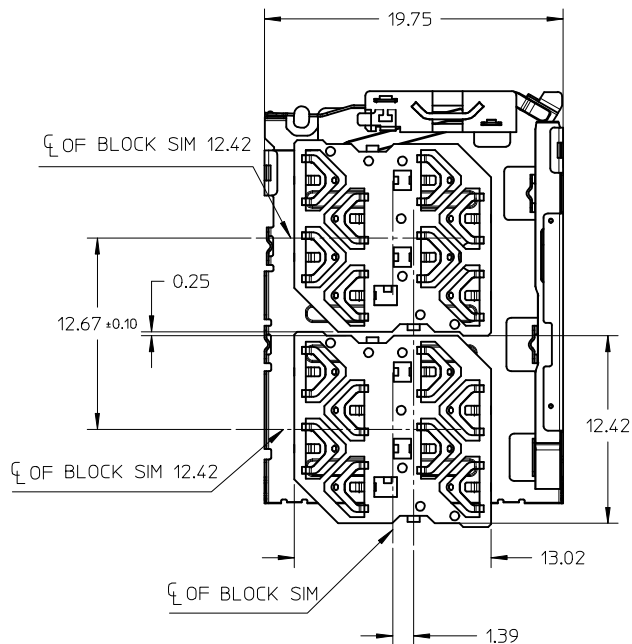
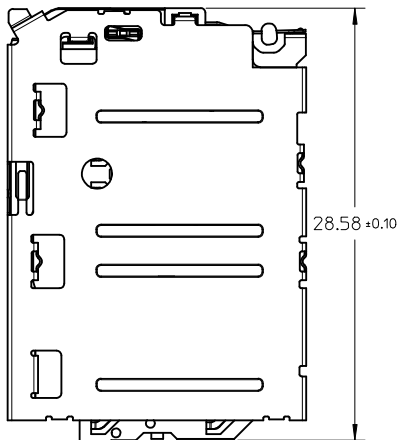

SIM CONNECTOR BOM

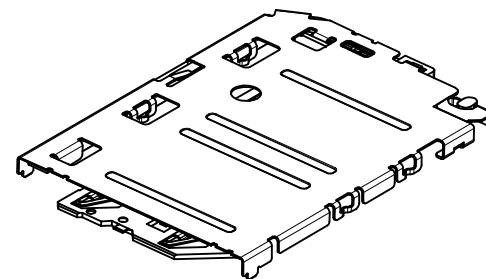

FRAME + BLOCK SIM

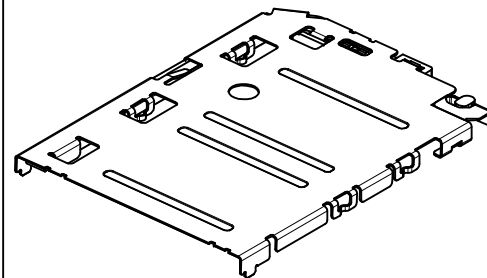

151031 SERIES

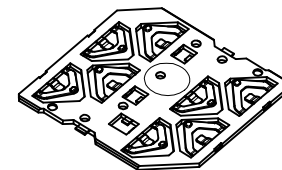

151032 SERIES

THIS DESIGN IS BASED ON DESIGN OBJECTIVES AND IS STRICTLY TENTATIVE. IT MAY CHANGE BASED ON RESULTS OF ADDITIONAL DESIGN REVIEWS & VERIFICATIONS.

SEE SHEET1	EC NO: S2015-0559	DESCRIPTION
	DRWN: JZENG	
	CHKD: JIAN02	
	APPR: KHL IM	

REV	DESCRIPTION
4	

QUALITY SYMBOLS	
$\nabla_A = 0$	
$\nabla_C = 0$	
$\nabla_P = 0$	
GENERAL TOLERANCES (UNLESS SPECIFIED)	
	mm INCH
4 PLACES	± --- ± ---
3 PLACES	± --- ± ---
2 PLACES	± 0.20 ± ---
1 PLACE	± 0.20 ± ---
0 PLACE	± --- ± ---
ANGULAR ± 3 °	
DRAFT WHERE APPLICABLE MUST REMAIN WITHIN DIMENSIONS	

DIMENSION STYLE	
MM ONLY	
DRAWN BY	DATE
JZENG	2013/12/13
CHECKED BY	DATE
APPROVED BY	DATE
KHL IM	2014/01/27
MATERIAL NO.	
1510313001	
SIZE	
A3	

SCALE	DESIGN UNITS	THIRD ANGLE PROJECTION
NTS	METRIC	
TITLE		
DUAL MICRO SIM FRAME 1.40H		
DOCUMENT NO.		SHEET NO.
SD-151031-0002		2 OF 5
THIS DRAWING CONTAINS INFORMATION THAT IS PROPRIETARY TO MOLEX INCORPORATED AND SHOULD NOT BE USED WITHOUT WRITTEN PERMISSION		



SIM CONNECTOR FRAME AND TRAY

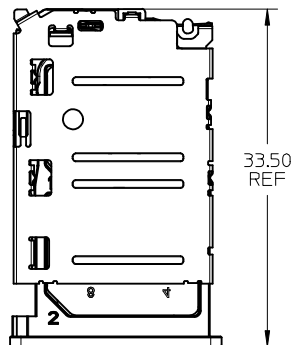

TRAY EJECTED POSITION

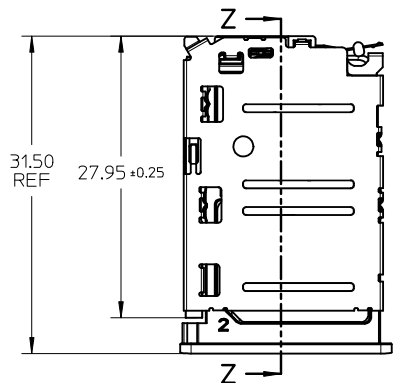

TRAY INSERTION POSITION

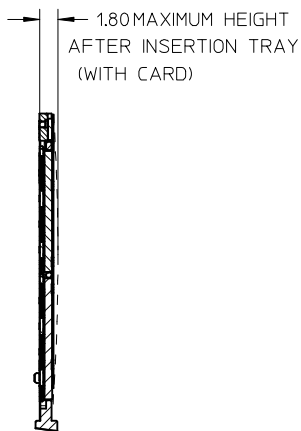

SECTION Z-Z

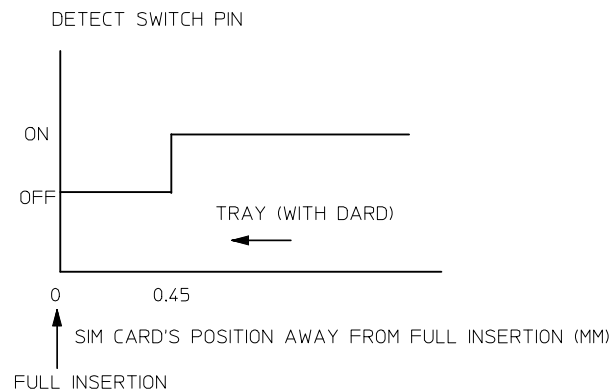
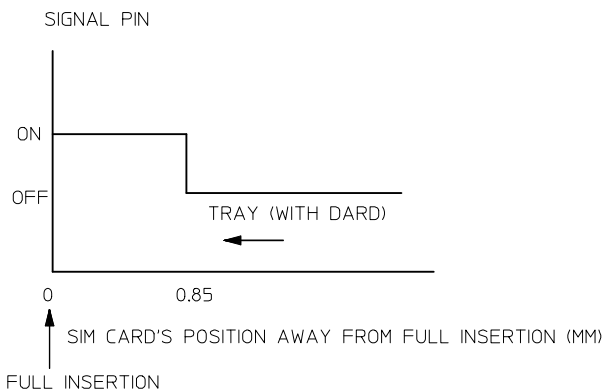
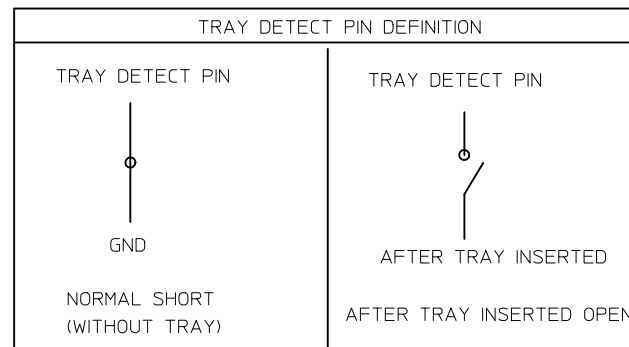

<p>SEE SHEET 1</p> <p>EC NO: S2015-0559</p> <p>DRWN: JZENG 2014/11/26</p> <p>CHKD: JIAN02 2014/12/22</p> <p>APPR: KHL IM 2014/12/24</p>	<p>QUALITY SYMBOLS</p> <p>$F_A=0$</p> <p>$F_G=0$</p> <p>$F_P=0$</p>	<p>GENERAL TOLERANCES (UNLESS SPECIFIED)</p>		<p>DIMENSION STYLE</p> <p>MM ONLY</p>	<p>SCALE</p> <p>METRIC</p>	<p>DESIGN UNITS</p> <p>METRIC</p>	<p>THIRD ANGLE PROJECTION</p>		
		<p>4 PLACES ± --- ± ---</p>	<p>3 PLACES ± --- ± ---</p>	<p>DRAWN BY</p> <p>JZENG</p>	<p>DATE</p> <p>2013/12/13</p>	<p>TITLE</p> <p>DUAL MICRO SIM FRAME 1.40H</p>			
		<p>2 PLACES ± 0.20 ± ---</p>	<p>1 PLACE ± 0.20 ± ---</p>	<p>CHECKED BY</p> <p></p>	<p>DATE</p> <p></p>	<p>APPROVED BY</p> <p>KHL IM</p>			<p>DATE</p> <p>2014/01/27</p>
		<p>0 PLACE ± --- ± ---</p>	<p>ANGULAR ± 3 °</p>	<p>MATERIAL NO.</p> <p>1510313001</p>		<p>DOCUMENT NO.</p> <p>SD-151031-0002</p>	<p>SHEET NO.</p> <p>3 OF 5</p>		
<p>4</p>	<p>REV</p>	<p>DRAFT WHERE APPLICABLE MUST REMAIN WITHIN DIMENSIONS</p>		<p>SIZE</p> <p>A3</p>	<p>THIS DRAWING CONTAINS INFORMATION THAT IS PROPRIETARY TO MOLEX INCORPORATED AND SHOULD NOT BE USED WITHOUT WRITTEN PERMISSION</p>				

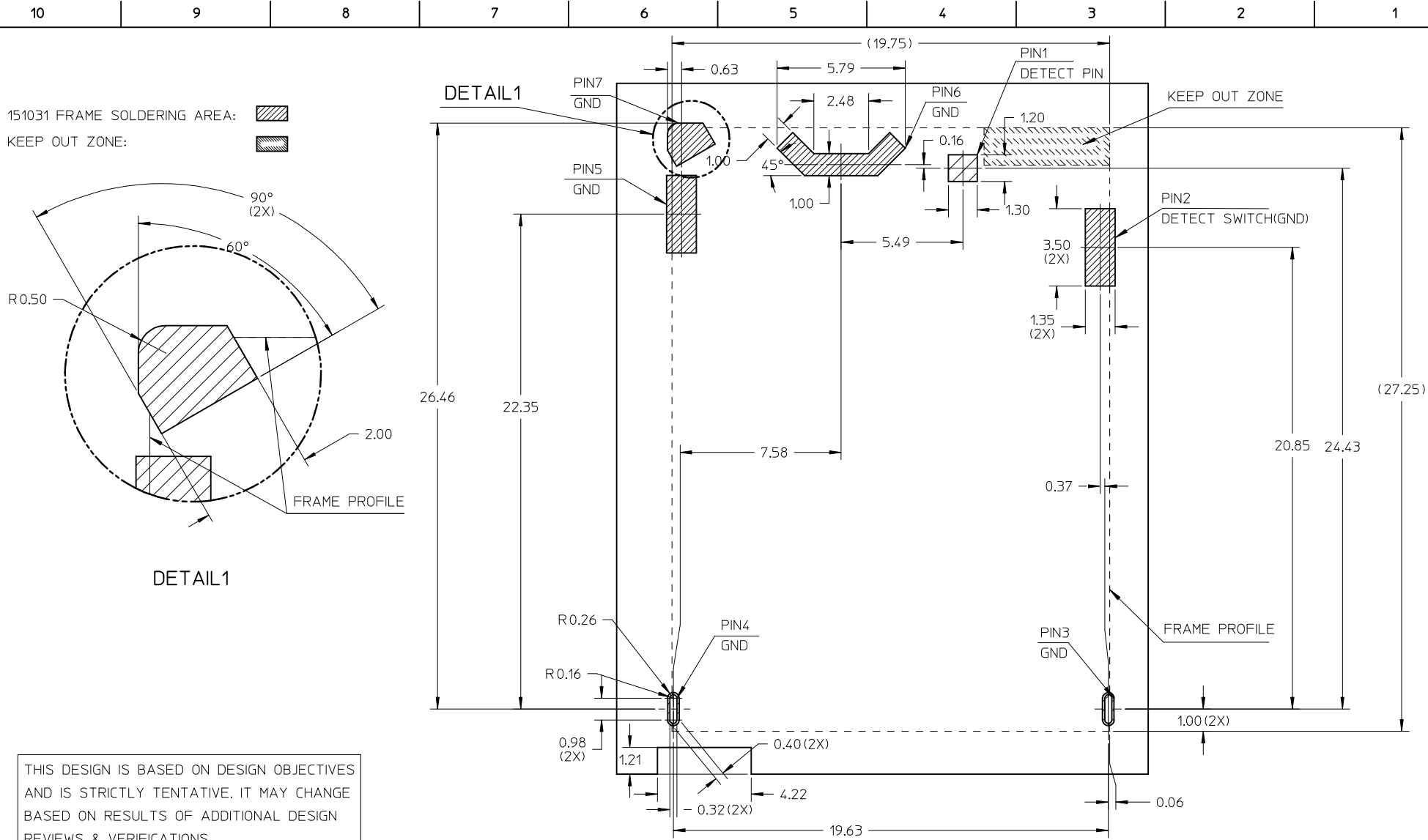



THIS DESIGN IS BASED ON DESIGN OBJECTIVES AND IS STRICTLY TENTATIVE. IT MAY CHANGE BASED ON RESULTS OF ADDITIONAL DESIGN REVIEWS & VERIFICATIONS.

RECOMMENDED PCB LAYOUT: TOLERANCE ± 0.05
 RECOMMENDED PCB THICKNESS: 1.00MM
 RECOMMENDED STENCIL THICKNESS: 0.10MM

SEE SHEET 1 EC NO: S2015-0559 DRWN: JZENG CHKD: JTAN02 APPR: KHL IM 2014/11/26 2014/12/22 2014/12/24	QUALITY SYMBOLS	GENERAL TOLERANCES (UNLESS SPECIFIED)	DIMENSION STYLE	SCALE	DESIGN UNITS	THIRD ANGLE PROJECTION																		
	$F_A=0$ $F_G=0$ $F_P=0$	<table border="1"> <thead> <tr> <th></th> <th>mm</th> <th>INCH</th> </tr> </thead> <tbody> <tr> <td>4 PLACES</td> <td>\pm ---</td> <td>\pm ---</td> </tr> <tr> <td>3 PLACES</td> <td>\pm ---</td> <td>\pm ---</td> </tr> <tr> <td>2 PLACES</td> <td>± 0.20</td> <td>\pm ---</td> </tr> <tr> <td>1 PLACE</td> <td>± 0.20</td> <td>\pm ---</td> </tr> <tr> <td>0 PLACE</td> <td>\pm ---</td> <td>\pm ---</td> </tr> </tbody> </table>		mm	INCH	4 PLACES	\pm ---	\pm ---	3 PLACES	\pm ---	\pm ---	2 PLACES	± 0.20	\pm ---	1 PLACE	± 0.20	\pm ---	0 PLACE	\pm ---	\pm ---	MM ONLY	NTS	METRIC	
		mm	INCH																					
	4 PLACES	\pm ---	\pm ---																					
3 PLACES	\pm ---	\pm ---																						
2 PLACES	± 0.20	\pm ---																						
1 PLACE	± 0.20	\pm ---																						
0 PLACE	\pm ---	\pm ---																						
<table border="1"> <thead> <tr> <th>DESCRIPTION</th> <th>DATE</th> <th>TITLE</th> </tr> </thead> <tbody> <tr> <td>DRAWN BY</td> <td>JZENG</td> <td>2013/12/13</td> </tr> <tr> <td>CHECKED BY</td> <td></td> <td></td> </tr> <tr> <td>APPROVED BY</td> <td>KHL IM</td> <td>2014/01/27</td> </tr> </tbody> </table>	DESCRIPTION	DATE	TITLE	DRAWN BY	JZENG	2013/12/13	CHECKED BY			APPROVED BY	KHL IM	2014/01/27	DUAL MICRO SIM FRAME 1.40H											
DESCRIPTION	DATE	TITLE																						
DRAWN BY	JZENG	2013/12/13																						
CHECKED BY																								
APPROVED BY	KHL IM	2014/01/27																						
4 REV	DRAFT WHERE APPLICABLE MUST REMAIN WITHIN DIMENSIONS	MATERIAL NO. 1510313001	DOCUMENT NO. SD-151031-0002	SHEET NO. 4 OF 5																				



THIS DRAWING CONTAINS INFORMATION THAT IS PROPRIETARY TO MOLEX INCORPORATED AND SHOULD NOT BE USED WITHOUT WRITTEN PERMISSION

151031 FRAME SOLDERING AREA: 
 151032 BLOCK SIM SOLDERING AREA: 

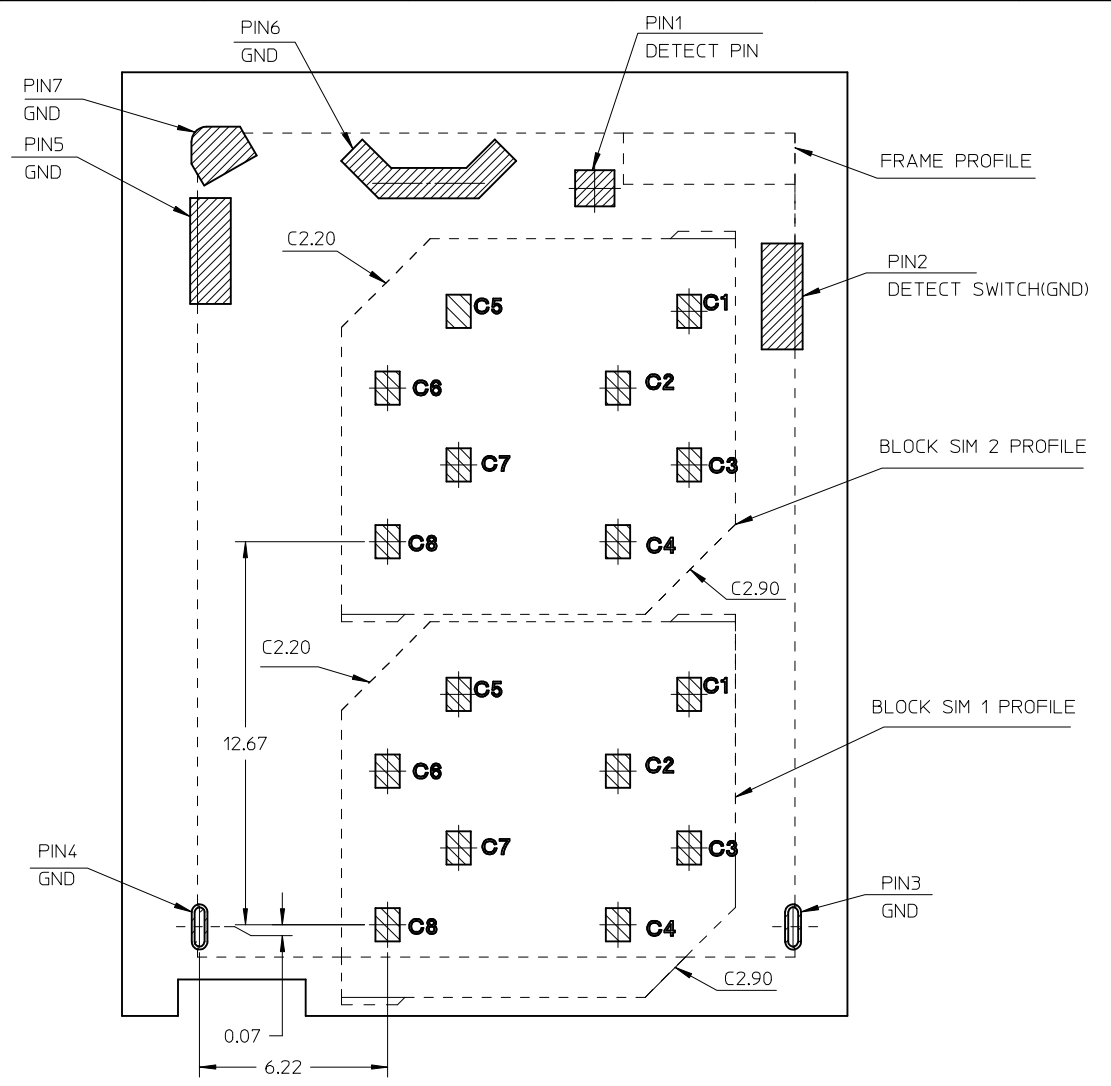

THIS DESIGN IS BASED ON DESIGN OBJECTIVES AND IS STRICTLY TENTATIVE. IT MAY CHANGE BASED ON RESULTS OF ADDITIONAL DESIGN REVIEWS & VERIFICATIONS.

RECOMMENDED PCB LAYOUT: TOLERANCE ±0.05
 RECOMMENDED PCB THICKNESS: 1.00MM
 RECOMMENDED STENCIL THICKNESS: 0.10MM

SEE SHEET 1	EC NO: S2015-0559	2014/11/26	QUALITY SYMBOLS	GENERAL TOLERANCES (UNLESS SPECIFIED)		DIMENSION STYLE MM ONLY		SCALE NTS	DESIGN UNITS METRIC	THIRD ANGLE PROJECTION		
	DRWN: JZENG	2014/12/22		$F_A=0$	mm	INCH	DRAWN BY JZENG	DATE 2013/12/13	TITLE DUAL MICRO SIM FRAME 1.40H			
	CHKD: JIAN02	2014/12/22		$F_G=0$	4 PLACES ± --- ± ---	3 PLACES ± --- ± ---	CHECKED BY	DATE				
	APPR: KHL IM	2014/12/24		$F_P=0$	2 PLACES ± 0.20 ± ---	1 PLACE ± 0.20 ± ---	APPROVED BY KHL IM	DATE 2014/01/27				
4	DESCRIPTION	REV	0 PLACE ± --- ± ---	ANGULAR ± 3 °		MATERIAL NO. 1510313001	DOCUMENT NO. SD-151031-0002	SHEET NO. 5 OF 5				
			DRAFT WHERE APPLICABLE MUST REMAIN WITHIN DIMENSIONS			SIZE A3	THIS DRAWING CONTAINS INFORMATION THAT IS PROPRIETARY TO MOLEX INCORPORATED AND SHOULD NOT BE USED WITHOUT WRITTEN PERMISSION					

Mouser Electronics

Authorized Distributor

Click to View Pricing, Inventory, Delivery & Lifecycle Information:

[Molex:](#)

[151031-3001](#)