

LOC	DIST	REVISIONS			
P	LTR	DESCRIPTION	DATE	DWN	APVD
CE	16	A	RELEASED	07JAN2011	KG DW

1. MATERIAL: NICKEL SILVER ALLOY.
2. FOR USE WITH CRIMP SUPPORT P/N'S 1918498-X OR 1985319-1.
3. DIMENSIONS ARE FOR REFERENCE ONLY.

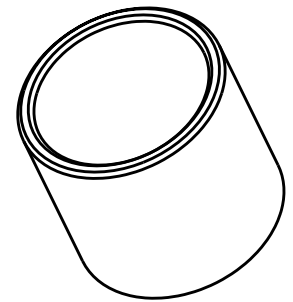
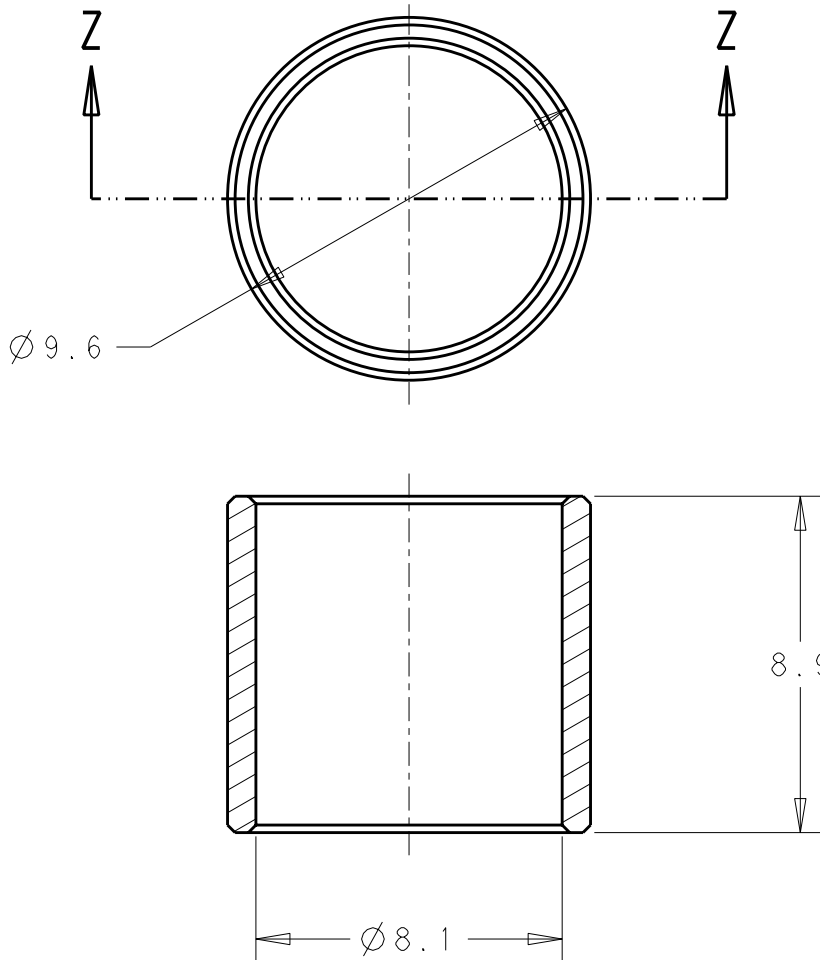

SCALE 3:1

SECTION Z - Z

1918497-1
PART NUMBER

DIMENSIONS: mm	DWN K. GLATFELTER	07JAN2011	MATERIAL	1 -	FINISH	-
	CHK D. WERTMAN	07JAN2011	Tyco Electronics Corporation Harrisburg, PA 17105-3608			
TOLERANCES UNLESS OTHERWISE SPECIFIED:	APVD D. WERTMAN	07JAN2011				
0 PLC ±-	PRODUCT SPEC	-	NAME CRIMP SLEEVE			
1 PLC ±-	APPLICATION SPEC	-	SIZE	CAGE CODE	DRAWING NO	RESTRICTED TO
2 PLC ±-			A 4	00779	C-1918497	-
3 PLC ±-			CUSTOMER DRAWING			
4 PLC ±-	WEIGHT	-	SCALE	5:1	SHEET 1 OF 1	REV A
ANGLES ±-						

Mouser Electronics

Authorized Distributor

Click to View Pricing, Inventory, Delivery & Lifecycle Information:

[TE Connectivity:](#)

[1918497-1](#)