

NOTES:

1. MATERIALS AND FINISHES:  
 BODY, CLAMP NUT, SHELL - BRASS, NICKEL PLATING  
 CONTACT - BeCu, SILVER PLATING  
 INSULATOR - TFE
2. ELECTRICAL:  
 A. IMPEDANCE: 50 OHM  
 B. DIELECTRIC WITHSTANDING VOLTAGE: 1500 VRMS, MIN.
3. MECHANICAL:  
 A. DURABILITY: 500 CYCLES MIN.  
 B. TEMPERATURE RANGE: -65°C TO +165°C
4. CABLE ASSEMBLY INSTRUCTIONS:  
 A. STRIP CABLE AS SHOWN.  
 B. SLIDE CLAMP NUT, WASHER, GASKET, SLEEVE OVER CABLE SHEATH.  
 C. COMB OUT THE BRAID AND FOLD OUT, TRIM EXCESS BRAID.  
 D. SLIDE SUB-ASSEMBLY TO THE REAR SIDE OF THE BODY AND TIGHTEN WITH PROPER SPANNER. MAKE ENSURE INTERFACE DIMENSIONS TO MEET.
5. PACKAGING:  
 A. QUANTITY: SINGLE PACK  
 B. MARKING: BAG TO BE MARKED  
 "AMPHENOL RF, 14625 AND DATE CODE"

THIRD ANGLE PROJ.

REVISIONS

REV	DESCRIPTION	DATE	ECO	APPR
--	REDRAWN NO CHANGE	-----	-----	-----
N	SEE SHEET 1	4/30/13	49490	CL

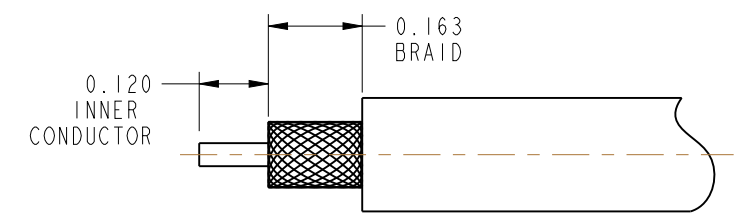

**RECOMMENDED CABLE STRIPPING DIMENSIONS**

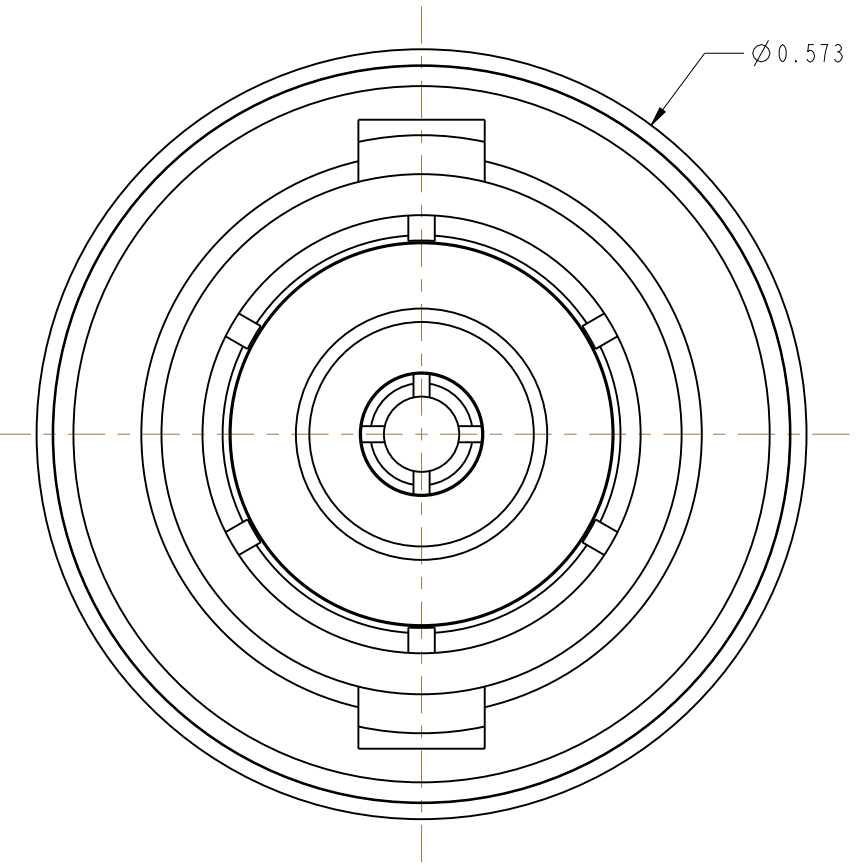
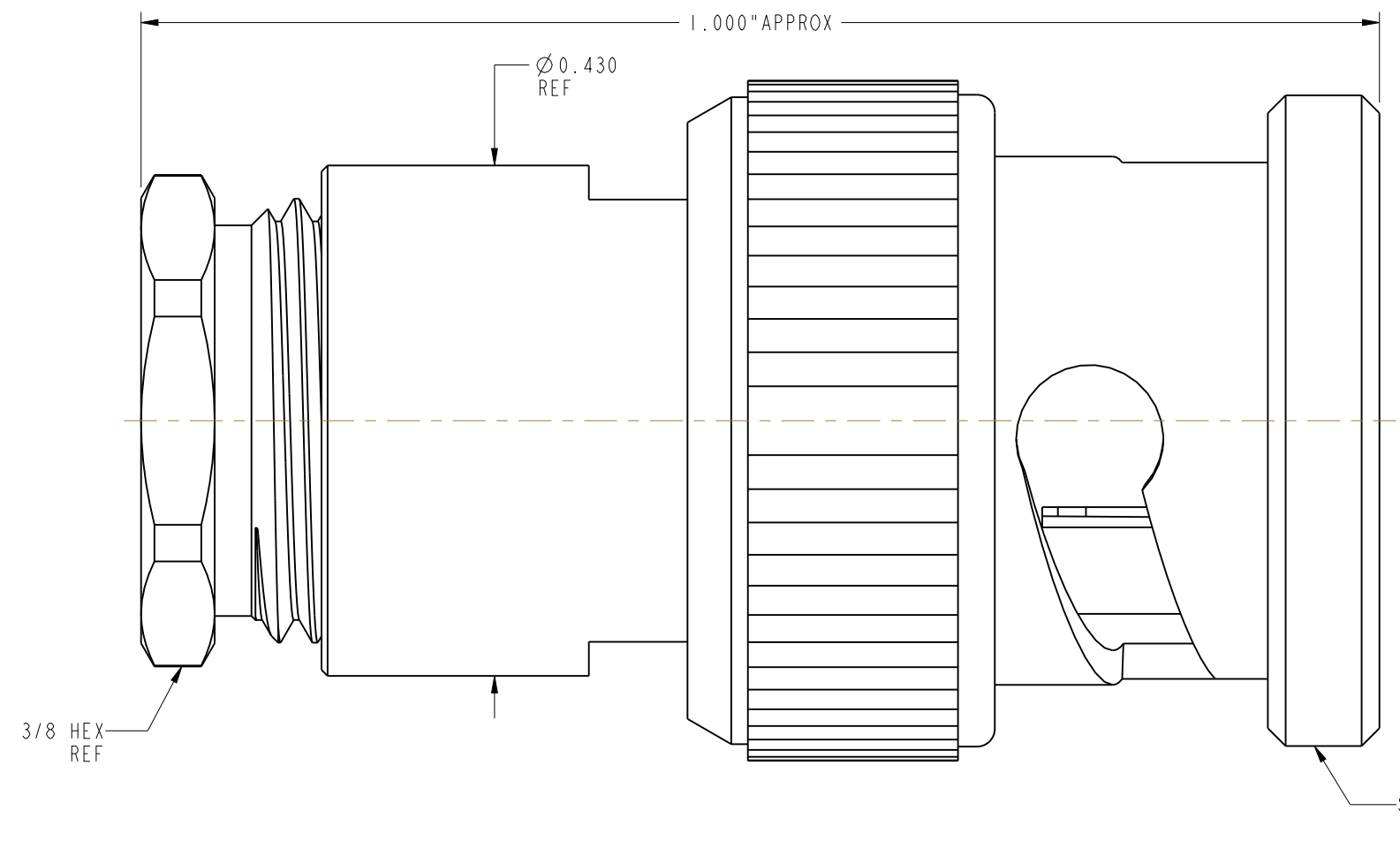
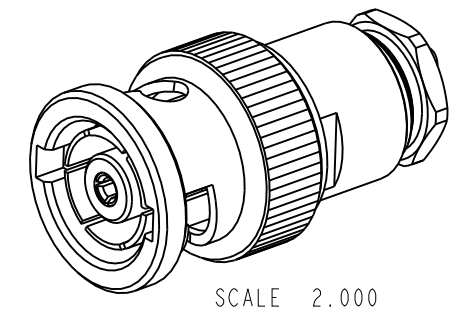

**CUSTOMER OUTLINE DRAWING**  
 ALL OTHER SHEETS ARE FOR INTERNAL USE ONLY

UNLESS OTHERWISE SPECIFIED, DIMENSIONS ARE IN INCHES AND TOLERANCES ARE: 2 PLACE DECIMAL 3 PLACE DECIMAL ANGLES $\pm 0.015$ (0,381 mm) $\pm 0.005$ (0,127 mm) $\pm 1^\circ$	MATERIAL	DRAWN	DATE	TITLE		Amphenol RF	
	SEE NOTES	CLEMENT	07-Mar-13				
	REFERENCE	ENGINEER	DATE	SCALE: 7.0:1.0 SHEET 2 OF 2		DRAWING NO. 14625	
	CONFIGURATION LEVEL: In Work	CLEMENT	07-Mar-13	DWG SIZE B		ITEM NO. 14625	
NOTICE - These drawings, specifications, or other data (1) are, and remain the property of Amphenol corp. (2) must be returned upon request; and (3) are confidential and not to be disclosed to any person other than those to whom they are given by Amphenol Corp. the furnishing of these drawings, specifications, or other data by Amphenol Corp., or to any other person to anyone for any purpose is not to be regarded by implication or otherwise in any manner licensing, granting rights to permitting such holder or any other person to manufacture, use or sell any product, process or design, patented or otherwise, that may in any way be related to or disclosed by said drawings, specifications, or other data.	FINISH	APPROVED	DATE	REV		PART NO. 14625	
		K. CAPOZZI	4/30/13	N			

# Mouser Electronics

Authorized Distributor

Click to View Pricing, Inventory, Delivery & Lifecycle Information:

[Amphenol:](#)

[14625](#)