

PART NUMBER	REV	FIRST USED	POWER UNIT	FEED TYPE	DESCRIPTION
1855105-1	A	122500-1	LEADMAKER	POST FEED	CUTS CARRIER
1855105-2	A	565435-5	BENCH MODEL K	PRE FEED	CUTS CARRIER
1855105-3	A	354500-1	BENCH MODEL G	PRE FEED	CUTS CARRIER
1855105-6	A	122500-1	LEADMAKER	POST FEED	CONTINUOUS CARRIER
1855105-8	A	122500-1	LEADMAKER	PRE FEED	CONTINUOUS CARRIER
7-1855105-7	A	-	-	-	SPARE PARTS

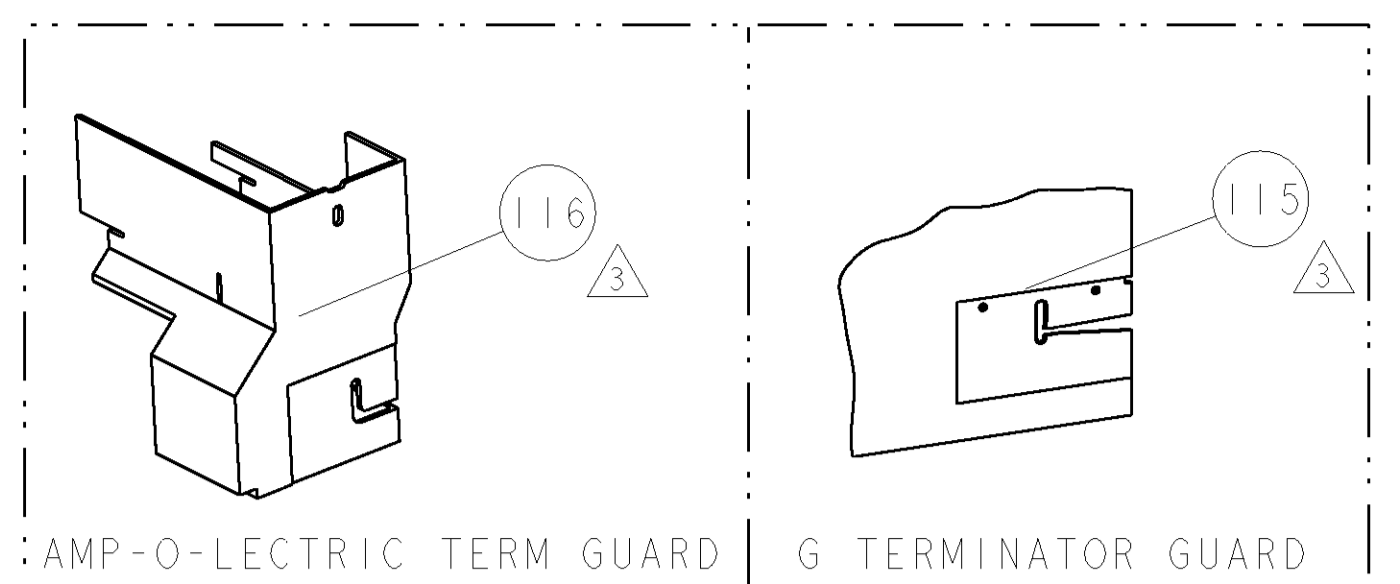

TERMINAL NAME: MAG-MATE POKE-IN TAB TERMINALS				
62897	-	-	-	AMP TERMINAL - AMP CRIMP SPECS
-	-	REF	CRIMP HEIGHT	WIRE SIZE
-	-	C0	.062±.002[1.57±0.05mm]	18 AWG
-	-	C7	.058±.002[1.47±0.05mm]	20 AWG
-	-	D5	.054±.002[1.37±0.05mm]	22 AWG
-	-	-	-	-
-	-	CRIMP	SIZE	TYPE
-	-	WIRE	.090 [2.29mm]	F
-	-	INSUL	-	-
WIRE STRIP LENGTH	TERM APPL SPEC	FEED	APPL INSTRUCTIONS	SET UP GAGE
.143 - .158	114-2050	.360	408-8040	458637-1

LOC	DIST	P	LTR	DESCRIPTION	DATE	DRN	APPR
A	66	-	-	RELEASED	25MAY2006	ROW	GB

- ① RECOMMENDED SPARE PARTS
- ② GREASE LIGHTLY
- ③ GUARD MUST BE IN PLACE WHEN OPERATING APPLICATOR IN A BENCH MACHINE

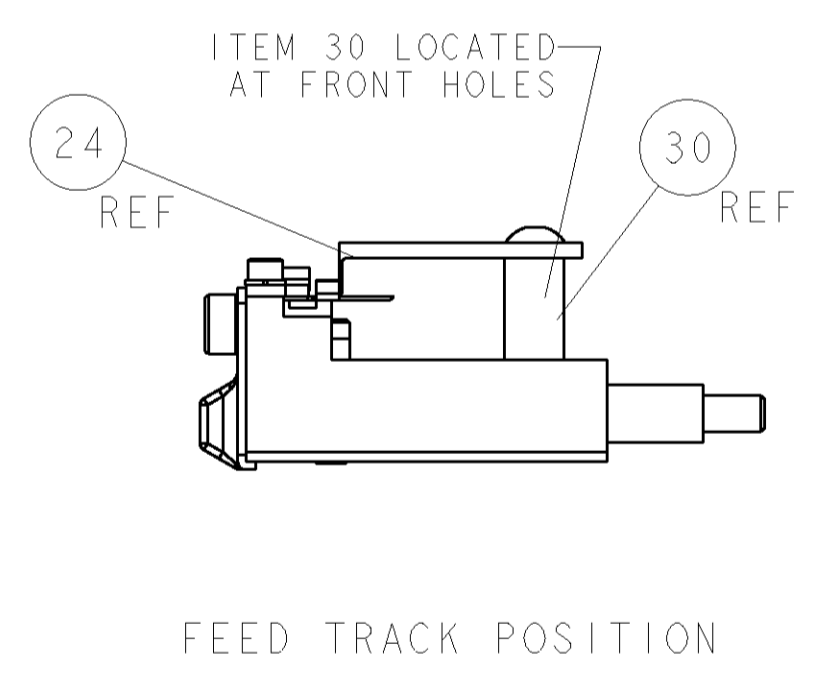
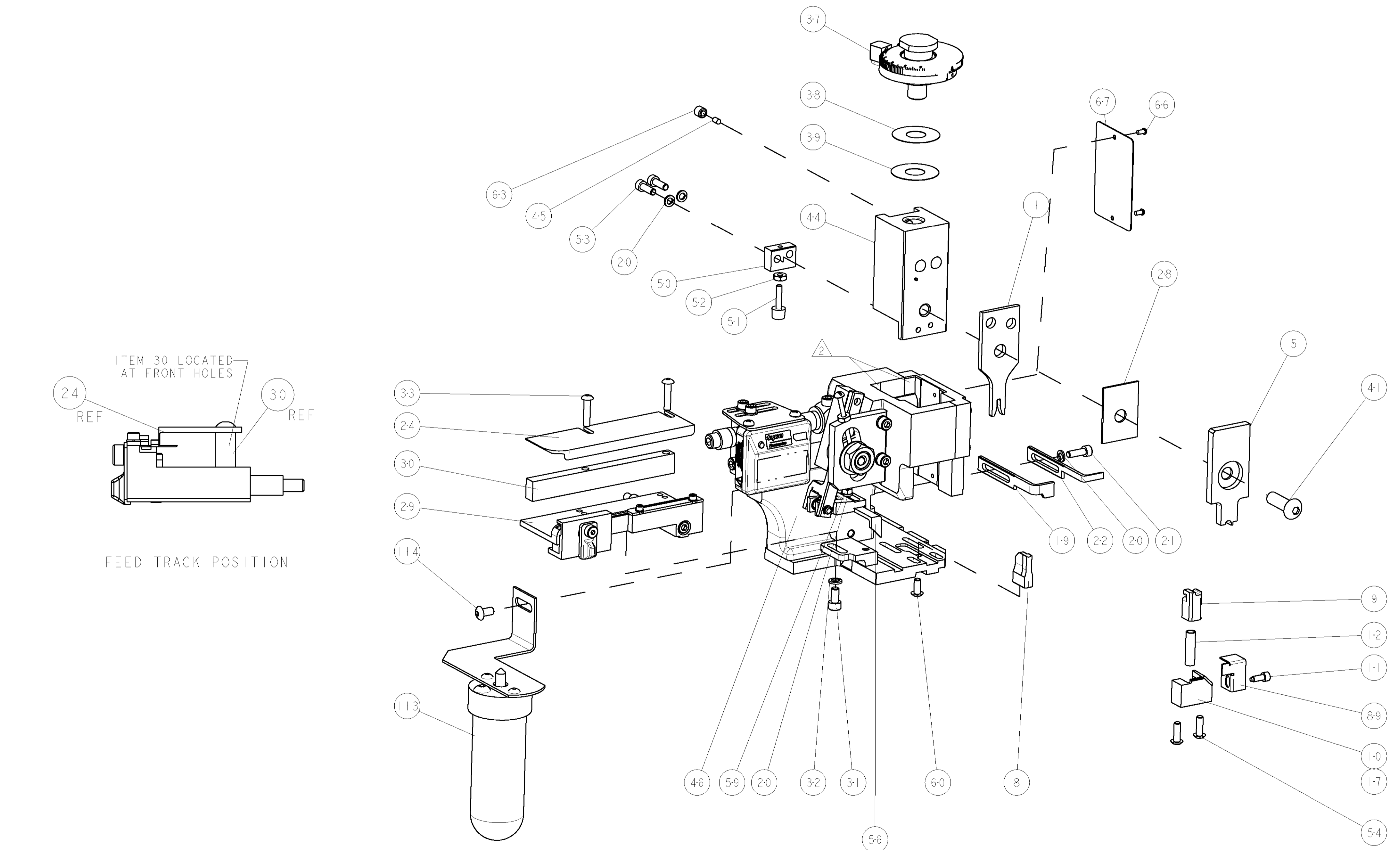

QTY	REF	DESCRIPTION	ITEM NO	
-	-	455749-1	GUARD WINDOW	116
-	-	679532-1	INSERT, GUARD	115
-	-	2-21002-6	SCR, BTN SKT HD CAP 10-32 X .375	114
-	-	1-465184-0	LUBRICATOR ASSY	113
-	-	1-21002-7	SCR, BTN SKT HD CAP 6-32 X .375	91
-	-	318563-1	GUARD, FRONT CHIP	89
-	-	4088040	SF APPL INST 408-8040	72
-	-	217238-1	GENERAL INSTRUCTION PKG	71
-	-	461264-5	PLATE, IDENTIFICATION	67
-	-	21017-2	SCREW, DRIVE	66
-	-	21009-2	SCR, SET, SELF LOCKING 1/4-20 X .250	63
-	-	22733-8	SCR, BHSC, SELF-LOCKING, 8-32 X .375	60
-	-	2-22603-0	SCR, HEX HD CAP 8-32 X .312	59
-	-	458537-2	PAWL, FEED	56
-	-	2-21002-2	SCR, BTN SKT HD CAP 8-32 X .500	54
-	-	2-21000-7	SCR, SKT HD CAP 8-32 X .500	53
-	-	21018-5	NUT, HEX, REG 6-32	52
-	-	811242-2	BUMPER, HOLD DOWN	51
-	-	690753-1	SPACER, TONKER	50
-	-	690602-6	CAM, PRE FEED, 1 5/8	49
-	-	690602-5	CAM, PRE FEED, 1 1/8	48
-	-	690501-4	CAM, POST FEED, 1 5/8	47
-	-	459456-1	APPL. BASIC SUB ASSY (SIDE WISE MOCA)	46
-	-	690191-1	PLUG, NYLON	45
-	-	455673-1	RAM, SIDE FEED	44
-	-	7-21002-9	SCR, BTN SKT HD CAP 5/16-24 X 1.00	41
-	-	690125-1	SHIM SUB-ASSY	39
-	-	469367-1	SHIM	38
-	-	879103-4	FINE ADJUST HEAD SUBASSY	37
-	-	2-21002-4	SCR, BTN SKT HD CAP 8-32 X .750	33
-	-	21024-5	WASHER, SPRG LOCK, REG NO 10	32
-	-	3-21000-4	SCR, SKT HD CAP 10-32 X .375	31
-	-	1320908-2	SPACER, STRIP GUIDE	30
-	-	1633091-1	ASSEMBLY, STRIP GUIDE	29
-	-	1-455888-0	SPACER, CRIMPER	28
-	-	1320928-2	PLATE, STRIP GUIDE	24
-	-	690472-6	STRIPPER	22
-	-	2-21000-7	SCR, SKT HD CAP 8-32 X .500	21
-	-	21024-4	WASHER, SPRG LOCK, REG NO 8	20
-	-	683369-1	STRIPPER	19
-	-	679625-1	SHEAR HOLDER, FRONT (NO CUT)	17
-	-	3-22280-3	SPRING, COMPRESSION	12
-	-	690461-1	STOP, SHEAR	11
-	-	690459-1	SHEAR HOLDER, FRONT	10
-	-	454276-1	FLOATING SHEAR, FRONT	9
-	-	4-690512-8	ANVIL, COMBINATION	8
-	-	1-455889-4	DEPRESSOR, SHEAR	5
-	-	3-456406-0	CRIMPER, WIRE PREMIUM	1

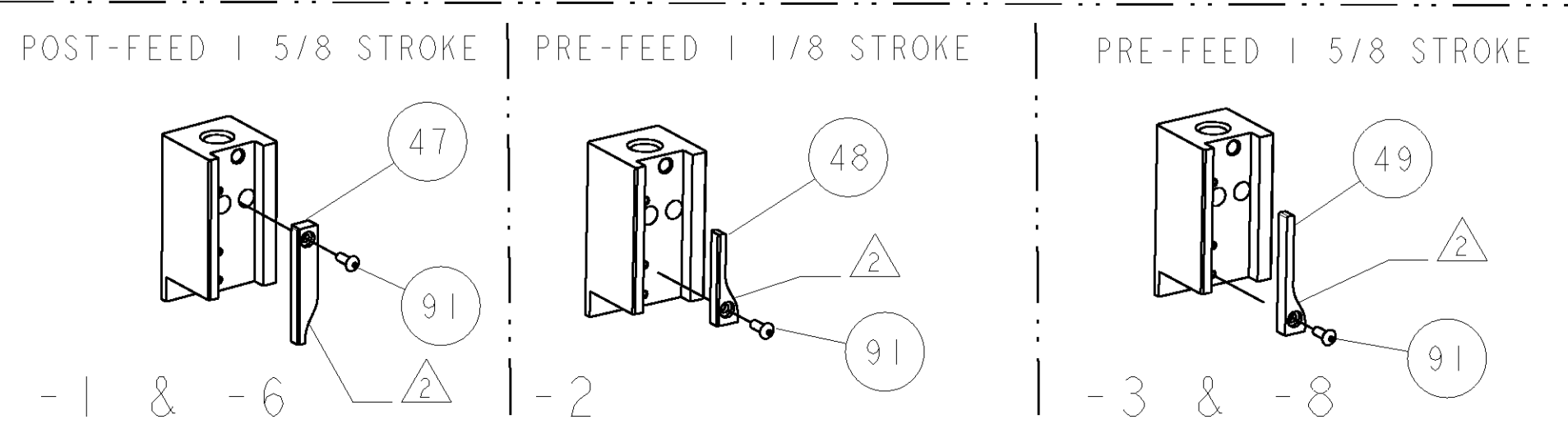

**\* WARNING:**  
ON INSTALLATION SET WIRE DISC TO LARGEST WIRE SIZE SETTING. USE OF SETTINGS BELOW MIN REQUIRED CRIMP HEIGHT SETTING WILL CAUSE DAMAGE TO CRIMP TOOLING.

DIMENSIONS: INCHES		TOLERANCES UNLESS OTHERWISE SPECIFIED:	
0 PLC	±	1 PLC	±0.1
1 PLC	±0.1	2 PLC	±0.01
3 PLC	±0.001	4 PLC	±0.0001
MATERIAL		FINISH	
-		-	
WEIGHT		SCALE 3:5	
-		SHEET 1 OF 1	
CUSTOMER DRAWING		REV A	

CUSTOMER VIEWABLE ASSEMBLY