

Screw Connectors for Printed Circuit Boards

TYPE 146-A-111

0.2 in. spacing - 2 to 24 poles



Series	Download PDF	3D Model	Can plug with	How to order	Color specifications	Print
------------------------	------------------------------	--------------------------	-------------------------------	------------------------------	--------------------------------------	-----------------------

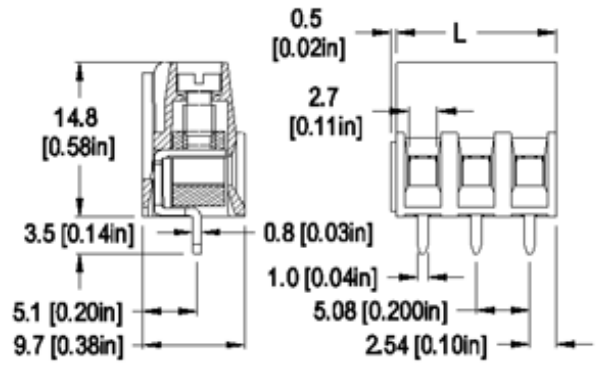
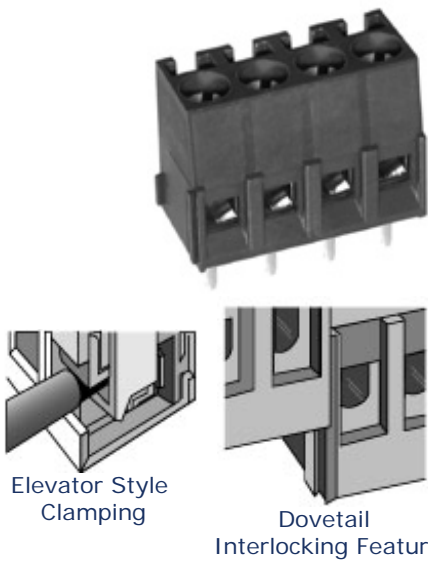

When locating connector, allow 0.5 mm clearance around it for process-induced variations.

Description

- Dovetail version
- Wire entrance parallel to PC Board
- Elevator-style clamping mechanism
- Can be factory, field or distributor assembled to almost any length

Technical Data

Center to Center Spacing: 5.08 mm (0.200 in.)
Nominal Cross Section: 2.5 mm² (3874 mils²)
Wire Stripping Length: 7 mm (0.28 in.)
Recommended Hole Diameter in PC Board: 1.4 mm (0.055 in.)

Approval Information

UL File No.E69841
 CSA File No.LR24322

Rating	Current(A)	Voltage(V)	Application group	AWG
UL	20	300	B,D	26-12
CSA	20	300	B,D,E	26-12

Screw Tightening Torque:

UL: 4.5 lbf·in
 CSA: 0.51 Nm

International Approvals:



Rated Impulse Withstand Voltage: 2500 V

Material

Molding: Polyamide, self extinguishing UL 94, V-0, color grey

Temperature limits:

Short Time: 140°C (284°F)

Continuous: RTI 105°C (221°F)

Low Limit: -40°C (-40°F)

Comparative Tracking Index: CTI > 600

Oxygen Index Rating: 33%

Terminal Body: Nickel plated copper alloy

Solder Pin and Pressure Plate: Tin plated copper alloy

Screw: M3, Slotted head, zinc plated blue passivated, steel substrate

Solder Pin: 1.0 mm x 0.8 mm (0.04 in. x 0.03 in.),

 [Top of page](#)

How to order

Item 146-A-111

Options

CN: Consecutive Numbering (hot stamped numbers)

SM: Special Marking (please provide sketch)

BS: Copper Alloy Screw

G05: Gold Plating (5 micro inches)

G30: Gold Plating (30 micro inches)

S30: Silver Plating (30 micro inches)

Note: Plated components: solder pin and pressure plate

146-A-111/

POLES:
02 to 24

[Request sample](#)

[Request quote](#)

Quantity

Accessories

[BST Self Adhesive Marking Strips.](#)

[Consecutively numbered.](#)

[Jumper, Type 970-J1.](#)

[Add to shopping cart](#)