

1:1

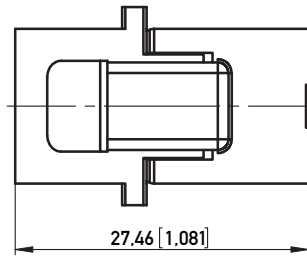

RECOMMENDED PANEL CUTOUT
EMPFOHLENER FRONTPLATTEN-AUSSCHNITT

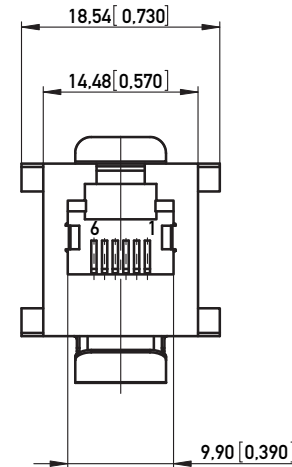
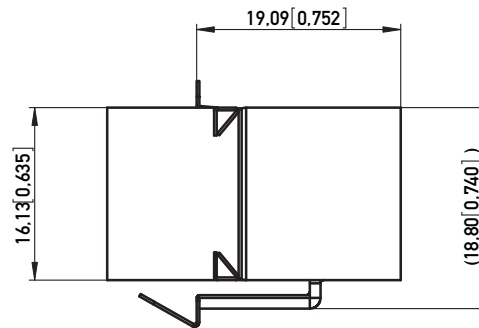
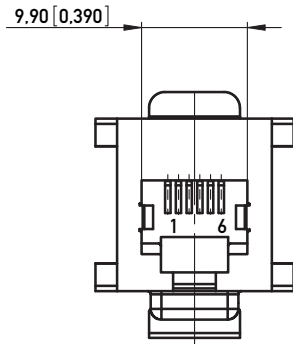
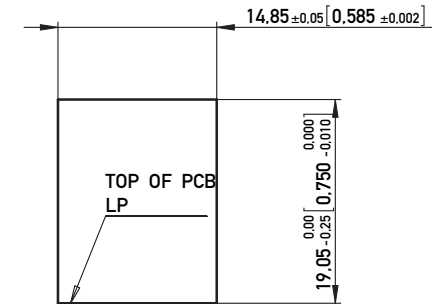

WIRING DIAGRAM

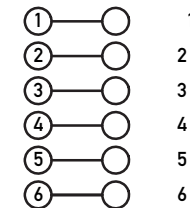

Technical specifications

Materials & Finish	Standard applic.	Value
Insulation body	Standard description	PBT 30%
Contact material	Standard description	C5210 (acc. JIS)
Contact finish, mating zone	Thickness of plating	30 µm Au over 50 µm Ni
Contact finish termination zone	Thickness of plating	N.A.
Shell/shield material	Standard description	SUS301 (acc. JIS)
Shell/shield plating	Thickness of plating	N.A.

Assembly process		
Packaging	Bag	
Solder temperature	N.A.	
Suitable assembly process	N.A.	

Approvals		
UL insulation body	UL 94	V0
UL File No.		E145413
RoHS compliant		Yes

Test Data	Standard applic.	Value
Mechanical properties		
Insertion/withdrawal force	IEC 603-7	max. 20 N
Mechanical operations	IEC 512-5, 9a	min. 1.000
Effectiveness of connector coupling device	IEC 512-8, 15f	50 N

Electrical properties		
Creepage / clearance distances		
a) Contact - contact	IEC 807-3	0.52 mm
b) Contact - shell	IEC 807-3	min. 1.0 mm
Voltage proof (Dielectric Withstand Voltage)		
a) Contact - contact	IEC 512-2, 4a	min. 1.000 V AC/DC
b) Contact - shell/testpanel	IEC 512-2, 4a	min. 1.500 V AC/DC
Current carrying capacity	IEC 512-3, 5b	1.5 A @ 25° C
Contact resistance	IEC 512-2, 2a	max. 30 mOhm
Insulation resistance	IEC 512-2, 3a	min. 500 MOhm

Environmental properties		
Operation temperature		0 - 70° C

NOTE 1 : C-UL APPROVED E145613 AND MEETS FCC REQUIREMENTS
NOTE 2 : RECOMMENDED PANEL THICKNESS 1.6 mm [0.062"]
NOTE 3 : RoHS COMPLIANT

Information:		Tolerances		Scale	2:1
		All Dimensions in mm(in)			
All rights reserved. Only for Information. To insure that this is the latest version of this drawing, please contact one of the ERNI companies before using.		Subject to modification without prior notice. Drawing will not be updated.		Designation	
				MOD JACK - MJC 6P6C, COUPLER, SHIELDED	
		www.ERNI.com		133420	
A	28.06.2007			1 (1/1)	
Index	Date			A3	
				Class	MJ

Copyright by ERNI GmbH
Proprietary notice pursuant to ISO 16016 to be observed.