

LOC	DIST	REVISIONS			
P	LTR	DESCRIPTION	DATE	DWN	APVD
AF	50	1	PROPOSED	-	-

- 1 CONTINUOUS STRIP ON REELS WITH TERMINALS LOCATED ON 6.86±0.08 [.270±.003] CENTERS
- 2 SLOT ACCEPTS 0.36-0.51mm [#27-#24] AWG COPPER MAGNET WIRE. TWO WIRES OF THE SAME SIZE MAX PER SLOT.
- 3 IDENTIFICATION NUMBER 10 FOR THE MAGNET WIRE SLOT SIZE.
- 4 0.25 [.010] MAX CARRIER CUT-OFF
- 5 PRELIMINARY - NOT FOR PRODUCTION

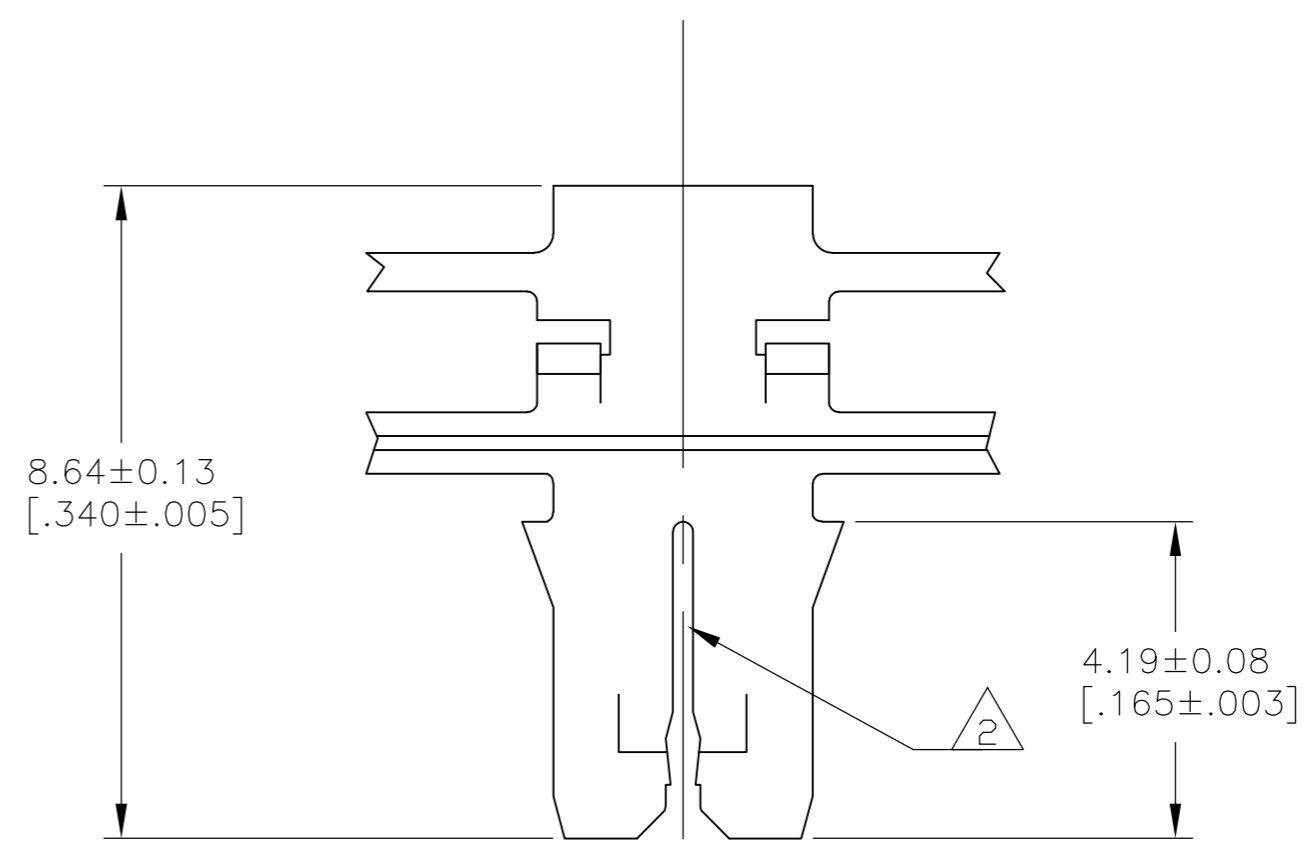
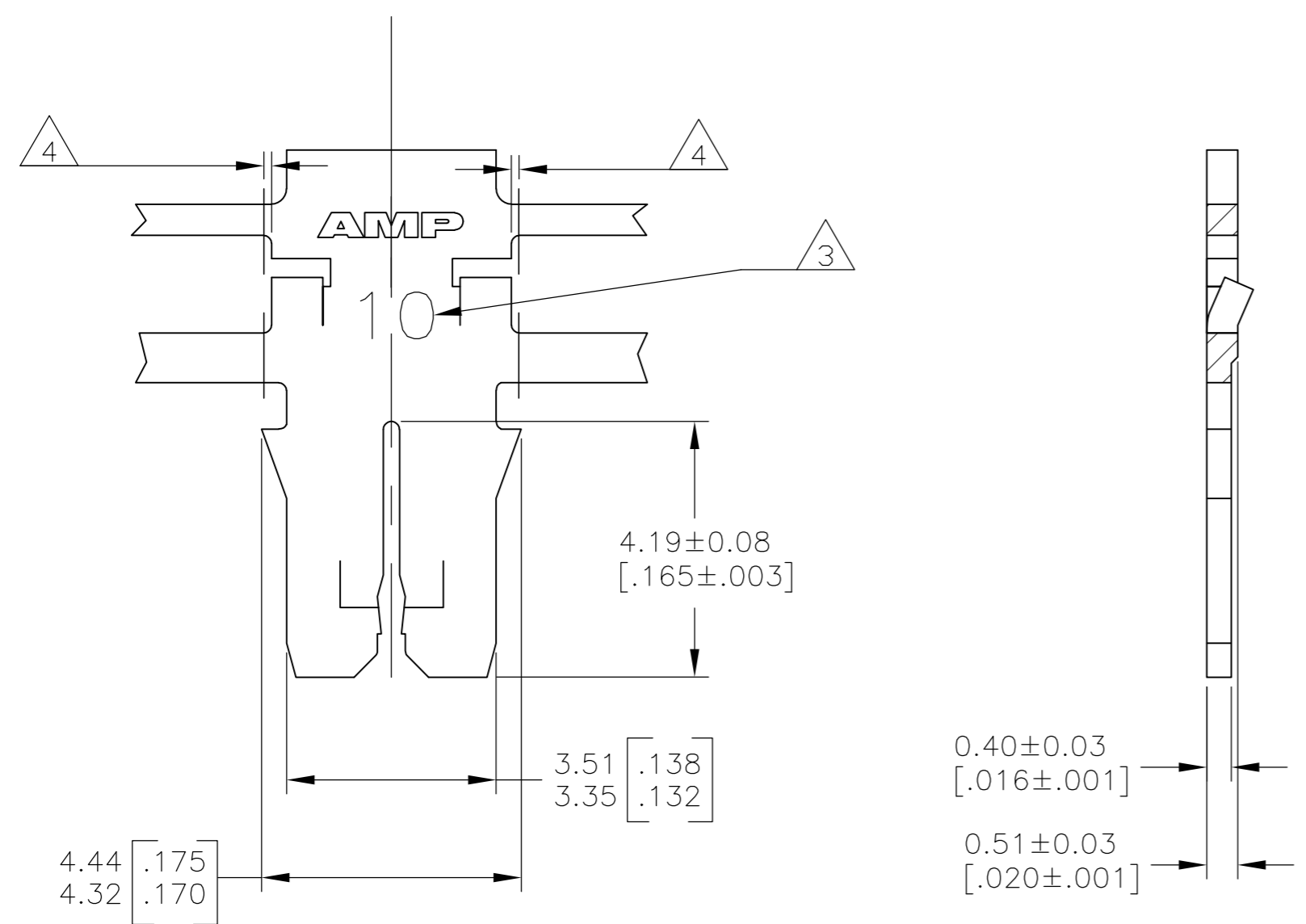

0.002032 [.000080] MIN TIN PLATE	082 PRE-MILLED BRASS	5 1742864-1
FINISH	MATERIAL	PART NO.

THIS DRAWING IS A CONTROLLED DOCUMENT.		DWN JR RUTH 27OCT10	Tyco Electronics Corporation Harrisburg, PA 17105-3608	
DIMENSIONS: MM [INCHES]		CHK KURT RANDOLPH 27OCT10	OBSCLETE NOT the LATEST REVISION	
TOLERANCES UNLESS OTHERWISE SPECIFIED:		APVD KURT RANDOLPH 27OCT10		
0 PLC ± -		PRODUCT SPEC 108-1484		
1 PLC ± -		APPLICATION SPEC 114-2140		
2 PLC ± 0.13 [.005]		WEIGHT -	SIZE A2	CAGE CODE 00779
3 PLC ± -		FINISH SEE TABLE	DRAWING NO. 1742864	RESTRICTED TO
4 PLC ± -		MATERIAL SEE TABLE	SCALE 10:1	SHEET 1 OF 1
ANGLES ± -		CUSTOMER DRAWING	REV 1	