

Please note that the data given here has been taken from the online catalog. For comprehensive information and data, please refer to the user documentation at <http://www.download.phoenixcontact.com>. The General Terms and Conditions of Use apply to Internet downloads.

## ► Extract from the online catalog

Headers, 3.5 mm pitch, color: black, plug-in direction parallel to the PCB



The figure shows a 10-position version of the product

Order No.	1937541
Ord designation	MC 1,5/ 7-G-3,5 THT
EAN	4017918890216
Pack	50 Pcs.
Customs tariff	85366990
Weight/Piece	0.003381 KG
Catalog page information	Page 138 (CC-2007)

## ► Product notes

WEEE/RoHS-compliant since: 01/01/2003



**IMPORTANT :** This date is valid for Customers in Germany only. Date Format is MM/DD/YYYY. Please contact your local in-country Phoenix Contact location or designated business partner for a Logistics Compliant date in your area. In order to guarantee delivery of RoHS-Compliant product, please purchase Phoenix Contact parts from authorized Phoenix Contact representatives and distributors.

MC 1,5/ 7-G-3,5 THT



---

▶ **Technical data**

---

---

**Dimensions / positions**

Pitch	3.5 mm
Dimension a	21 mm
Number of positions	7
Pin dimensions	0,8 x 0,8 mm
Hole diameter	1.4 mm

---

**Technical data**

Insulating material group	IIIa
Rated surge voltage (III/3)	2.5 kV
Rated surge voltage (III/2)	2.5 kV
Rated surge voltage (II/2)	2.5 kV
Rated voltage (III/2)	160 V
Rated voltage (II/2)	320 V
Connection in acc. with standard	EN-VDE
Nominal current $I_N$	8 A
Nominal voltage $U_N$	160 V
Maximum load current	8 A (per position)
Insulating material	PA-F
Inflammability class acc. to UL 94	V0

---

## Drawings

### Application drawing

The Steps for the "PIN-in-Paste" Procedure

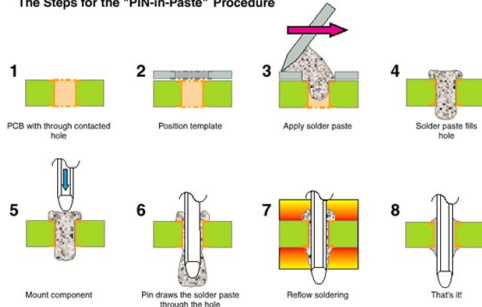

### Tips and Recommendations for Users

#### Hole and Pad Dimensions/Pin Geometries

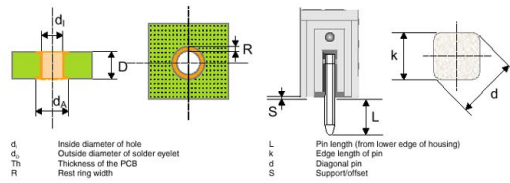

	Actual dimensions	Recommendations
MINI COMBICON	$d = 1,15 \text{ mm}$ $k = 0,8 \text{ mm}$ $S = 0,3 \text{ mm}$	$d_i = 1,3 \text{ mm}^{1)}$ $R = 0,5 \text{ mm}^{2)}$

<sup>1)</sup> Hole diameter acc. to DIN IEC 60 352-5 and taking into account the mounting accuracy of automatic mounting machines.  
<sup>2)</sup> The recommended rest ring width of 0.5 mm refers to case II/2 on the PCB (surge voltage category/contamination class) assuming a rated voltage of 160 V (MC 1,5) for the component. When the rest ring width is determined, the requirements for air and creepage distances acc. to the respective equipment standards must be taken into account; smaller rest ring widths or other pad geometries must be used if necessary.

#### Applying Solder Paste

It is assumed that a conventional template print procedure is used when applying the solder paste.

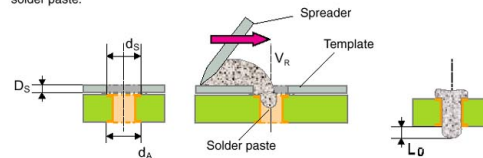

$d_o$  Outside diameter of solder eyelet  
 $d_i$  Inside diameter of hole -0.1 mm  
 $Th$  Template thickness = recommended thickness of template 150  $\mu\text{m}$   
 $V_s$  Spreader speed = 30-150 mm/sec. )  
 $S_s$  Solder paste overhang = up to 1/2 printed circuit board thickness

<sup>1)</sup> Speed of spreader and pressure depend on the type of screen printer and the solder paste; e.g. Sn 62 Pb 36 Ag 2 with 20-40  $\mu\text{m}$  grain ( $V_S$  = approx. 50 mm/sec).

#### Reference Profile for Reflow-Solder Processes

A temperature profile based on EN 61 760-1 is recommended:

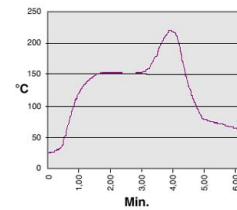

- Parameters/Settings:
- Creating temperature profile: Preferably with forced convection or vapor phase furnace.
  - The use of infra-red radiation should be avoided if possible.
  - Maximum temperature/time ranges: 215 °C for 30 seconds and 230 °C for 15 seconds.
  - Profiles with temperature loads that last considerably longer than 4.5 min. until the peak temperatures are reached should be avoided.
  - The whole profile cycle should take approx. 5 min.
  - Pre-heating to achieve even heating up of the components: 210 to 240 sec.
  - Cooling down phase: min. 4°C/sec.

### Drilling diagram

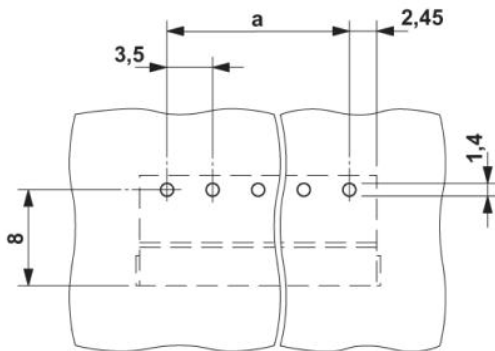

### Dimensioned drawing

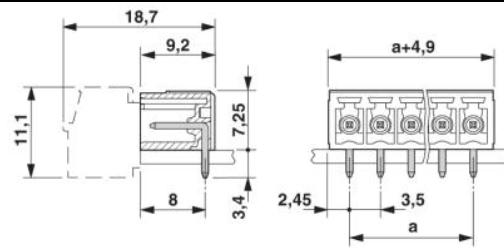
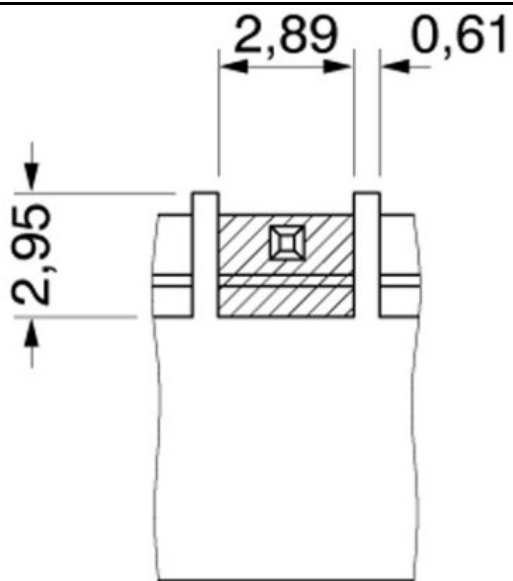

Bottom view, free space for solder paste, 0.3 mm deep



---

## ► Address

---

PHOENIX CONTACT GmbH & Co. KG  
Flachsmarktstr. 8  
32825 Blomberg  
Germany  
Phone +49 5235 3 00  
Fax +49 5235 3 41200  
<http://www.phoenixcontact.de>  
Phoenix Contact  
Technical modifications reserved;