

NOTES:
1. DO NOT SCALE THIS DRAWING

2. MATERIALS OF CONSTRUCTION:
BODY, WASHER & LOCKING SLEEVE = BRASS, NICKEL PLATED (.000100 THICK)
MALE CONTACT = BRASS, GOLD PLATED (.000005 THICK)
OUTER CONTACT: BeCu, GOLD PLATED (.000005 THICK)
INSULATION: PTFE
COIL SPRINGS (2) = STAINLESS STEEL, PASSIVATED
BALLS (3) = INOX, PASSIVATED
FERRULE = SEAMLESS COPPER, NICKEL PLATED (.000100 THICK)

3. ELECTRICAL:
A. IMPEDANCE = 75 OHMS
B. FREQUENCY RANGE = DC - 2 GHz
C. VSWR (RETURN LOSS) = 1.23 (19.7) MAX

4. CRIMP USING TOOL (.178 HEX)
SOLDER CONTACT

102-799-7535		REVISIONS			
DRAWING NO.	REV	DESCRIPTION	DATE	ECO	APPR
THIRD ANGLE PROJ.	A	RELEASE TO MFG	7/17/06	46177	MAH
	B	.000005 THICK GOLD ON CONTACTS WAS .000030 THICK	8/28/06	46219	MAH

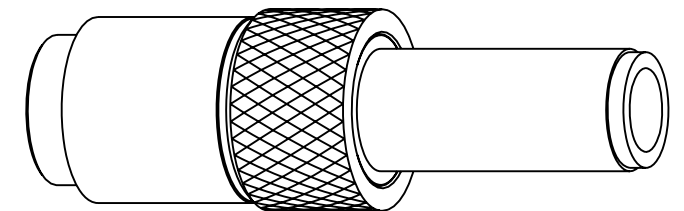

SCALE 3.000

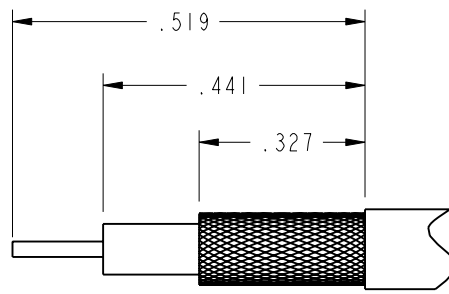
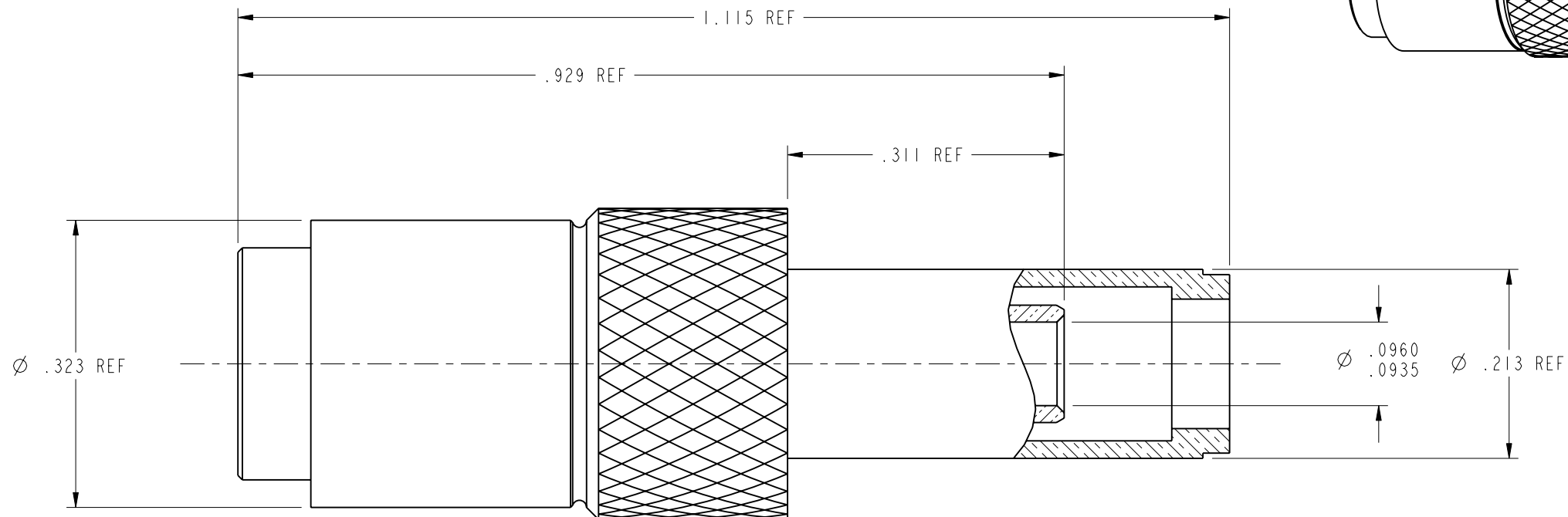

RECOMMENDED CABLE
STRIPPING DIM'S

SCALE 4.000

CUSTOMER OUTLINE DRAWING

ALL OTHER SHEETS ARE FOR INTERNAL USE ONLY

UNLESS OTHERWISE SPECIFIED, DIMENSIONS ARE IN INCHES AND TOLERANCES ARE: 2 PLACE DECIMAL ±.015 (0,381 mm) 3 PLACE DECIMAL ±.005 (0,127 mm) ANGLES ± 1°	MATERIAL	DRAWN MIKE HOYACK	DATE 11-Jul-02	TITLE 1.0/2.3 PUSH PULL PLUG 75 OHM 735A CABLE		Amphenol RF Danbury, CT, USA Tainan, Taiwan Shenzhen, China www.amphenolrf.com
	REFERENCE EAR 637 & 2132 GEN# ASSYM4_1023 615X-1814-100	ENGINEER MIKE HOYACK	DATE 06-Jun-02			
NOTICE - These drawings, specifications, or other data (1) are, and remain the property of Amphenol Corp. (2) must be returned upon request; and (3) are confidential and not to be disclosed to any person other than those to whom they are given by Amphenol Corp. The furnishing of these drawings, specifications, or other data by Amphenol Corp., or to any other person to anyone for any purpose is not to be regarded by implication or otherwise in any manner licensing, granting rights or permitting such holder or any other person to manufacture, use or sell any product, process or design, patented or otherwise, that may in any way be related to or disclosed by said drawings, specifications, or other data.		CAD FILE I:\1023\102-799-7535	CODE ID 74868	DWG SIZE B	DRAWING NO. 102-799-7535	SCALE: 6.0:1
						SHEET 2 OF 2
						REV B

Mouser Electronics

Authorized Distributor

Click to View Pricing, Inventory, Delivery & Lifecycle Information:

[Amphenol:](#)

[102-799-7535](#)