

AT ALL TIMES WATER RESISTANT CONNECTORS NOT IN USE SHOULD BE COVERED WITH A CONEC WATER RESISTANT CAP OR WATER TIGHT HOOD.

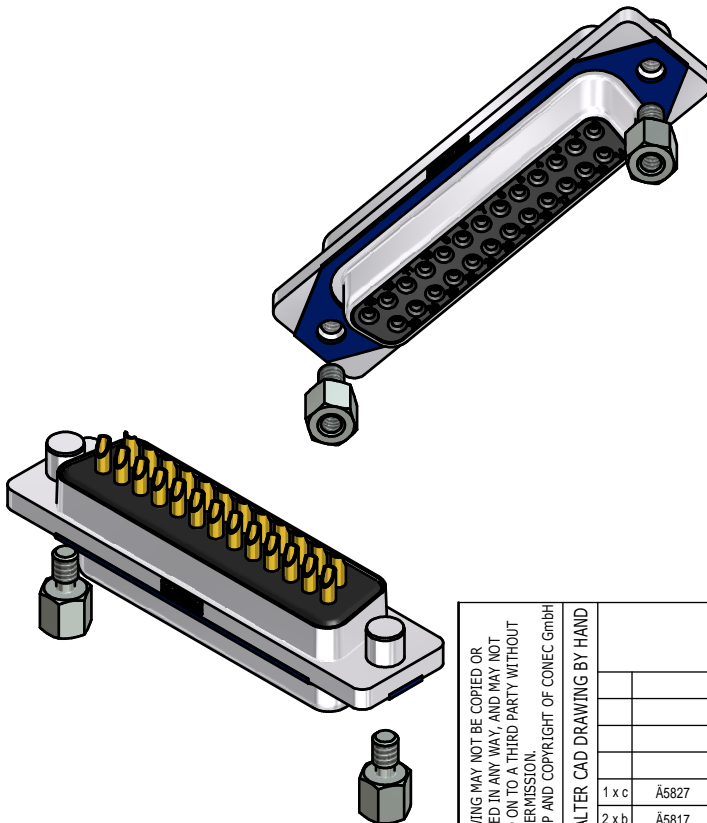
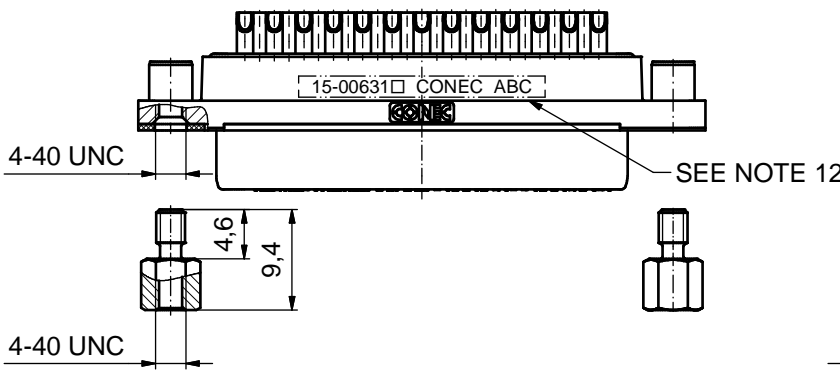
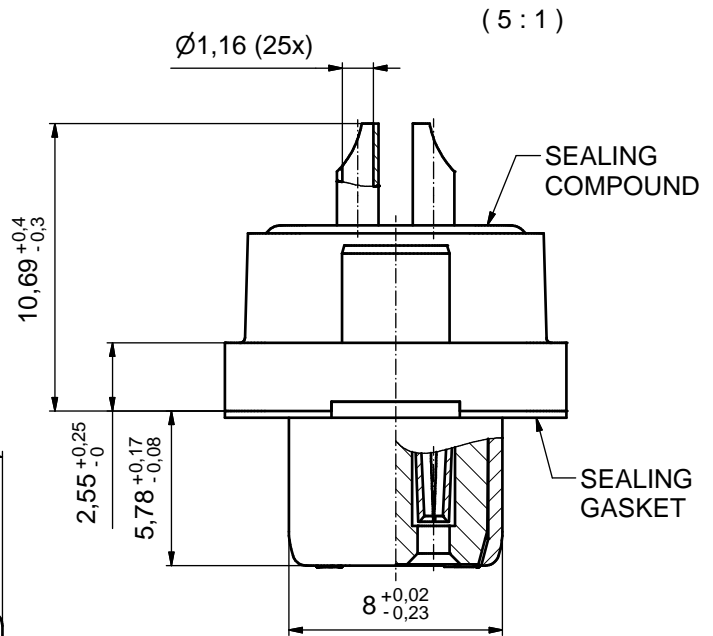
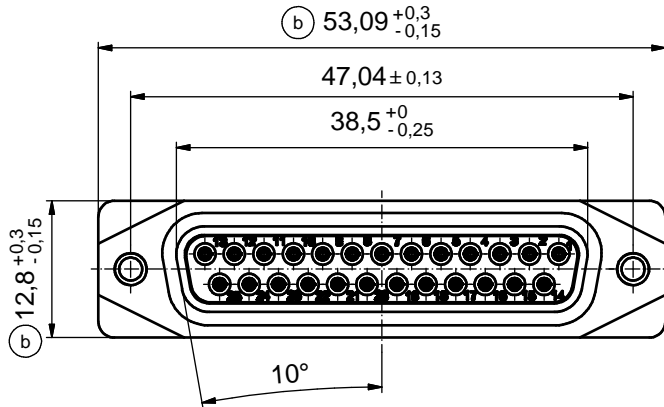

RoHS compliant

NOTES:

1. RECOMMENDED SOLDER INSTRUCTION SEE SHEET 2
2. IP RATING: IP 67
3. SEALED TO WITHSTAND PRESSURE UP TO 1,45 PSI FOR 30 MINUTES AFTER SOLDERING
4. METALSHELL: ZINC DIE CAST; min. 50µm NICKEL PLATING over COPPER
5. INSULATORS: PBT GF UL 94 V-0; BLACK
6. SEALING GASKET: SILICONE; BLUE
7. SEALING COMPOUND: EPOXY RESIN UL 94 V-0; BLACK
8. CONTACTS: COPPER ALLOY; PLATING (SEE PART-NO.):  
 PLEASE ADD 1 for 30µm HARD GOLD over min. 50µm NICKEL  
 PLEASE ADD 3 for GOLD FLASH over NICKEL  
 SOLDER CUP ACCEPTS CABLE AWG 20
9. HEXLOCKING SCREWS: STAINLESS STEEL
10. RECOMMENDED PANEL CUT-OUT ON SHEET 2
11. RECOMMENDED TORQUE FOR MOUNTING SCREW  
 35Ncm (3.1 in.LB) / max. 67Ncm (6 in.LB)
12. CONNECTOR IS PART MARKED: [15-00631] CONEC ABC (see note 8)

THIS DRAWING MAY NOT BE COPIED OR REPRODUCED IN ANY WAY, AND MAY NOT BE PASSED ON TO A THIRD PARTY WITHOUT WRITTEN PERMISSION. OWNERSHIP AND COPYRIGHT OF CONEC GmbH DO NOT ALTER CAD DRAWING BY HAND				tolerance		dim. in mm	scale: 2:1 (5:1)	
				date			material: SEE NOTES	
		drawn 23.09.14		name		title: <b>D-SUB FEMALE</b> 25pos. SOLDER CUP with closed 4-40 UNC thread		
		appd. 26.01.15		Fischer				
		norm						
		d-old						
1 x c	Ä5827	25.09.15	Unkrüer			dwg no:		DIN-A3
2 x b	Ä5817	15.09.15	M.H.			15K1A1538		
a	Original							sh: 1
rev.	description	date	name			part no: 15-00631 (see note 8)		



### © Solder Instruction

1. Cable should be prepared for soldering. The cable/wires must be pretinned.
2. Insert cable/wire into solder cup.
3. Operate the soldering iron at 350°C, 50 Watt max. and use a pencil tip.
4. Apply some solder to the solder tip of the soldering iron.
5. Put tip to wire in solder cup.
6. After 1 second bring in solder.
7. Heat for 3 seconds longer. Do not heat contact more than 4 seconds in total.
8. Remove soldering iron.
9. Wait until solder gets rigid again.
10. Do not solder adjacent contacts consecutively, alternate position within the connector to minimize heat build up.

### RECOMMENDED PANEL CUT-OUT

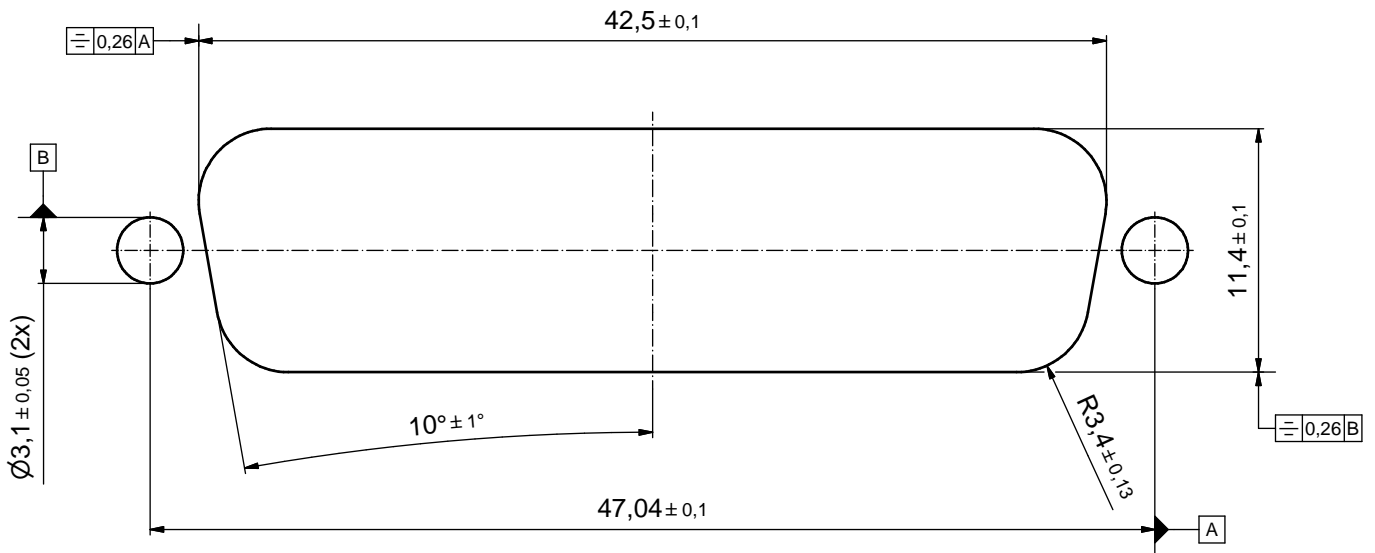

THIS DRAWING MAY NOT BE COPIED OR REPRODUCED IN ANY WAY, AND MAY NOT BE PASSED ON TO A THIRD PARTY WITHOUT WRITTEN PERMISSION. OWNERSHIP AND COPYRIGHT OF CONEC GmbH DO NOT ALTER CAD DRAWING BY HAND				tolerance		scale: 4:1
				date	name	material: SEE SHEET 1
				drawn	23.09.14	Lehmenkühler
				appd.	26.01.15	Fischer
				norm		
			d-old			
1 x c	Ä5827	25.09.15	Unkrüer	<b>RECOMMENDED PANEL CUT-OUT</b> D-SUB FEMALE 25pos. SOLDER CUP with closed 4-40 UNC thread		
a	Original					
			<b>CONEC®</b>		dwg no:	DIN-A3
rev.	description	date			name	15K1A1538
					part no:	SEE SHEET 1

# Mouser Electronics

Authorized Distributor

Click to View Pricing, Inventory, Delivery & Lifecycle Information:

[CONEC:](#)

[15-006313](#)