

## Our Products

[7/16](#)  
[BNC](#)  
[D-Sub](#)  
[FME](#)  
[MCX](#)  
[MMCX](#)  
[SMA](#)  
[SMB](#)  
[SMC](#)  
[TNC](#)  
[Twin BNC](#)  
[Type F](#)  
[Type N](#)  
[UHF](#)

[Between-Series Adapters](#)  
[Shielded Terminations](#)  
[Strain-Relief Boots](#)  
[Tools](#)

[View All Products](#)

**Search Results for:** Straight Crimp Jack - Miniature And Semi-Rigid Cable

*Please note: Images are for reference only*



**Part Number:** 112529  
**Family/Series:** BNC Coaxial Connectors  
**Product Type:** JACK CRIMP ATTACHMENTS FOR FLEXIBLE CABLE  
**Description:** Straight Crimp Jack - Miniature And Semi-Rigid Cable  
**Cable:** 316/U DOUBLE BRAIDED \*\*

**Cable Group:** 05A  
**Finish:** Nickel  
**Insulation:** Teflon  
**Impedance:** 50 ohms  
**Crimp Tool:** [B](#)  
**Remark:** With teflon sleeve, Hex crimp size .178"

[Add to Cart](#) | [Product Specs](#) | [Customer Drawing](#)

REV.	DATE	DESCRIPTION
A	10/28/99	MODIFY FERRULE PLATING

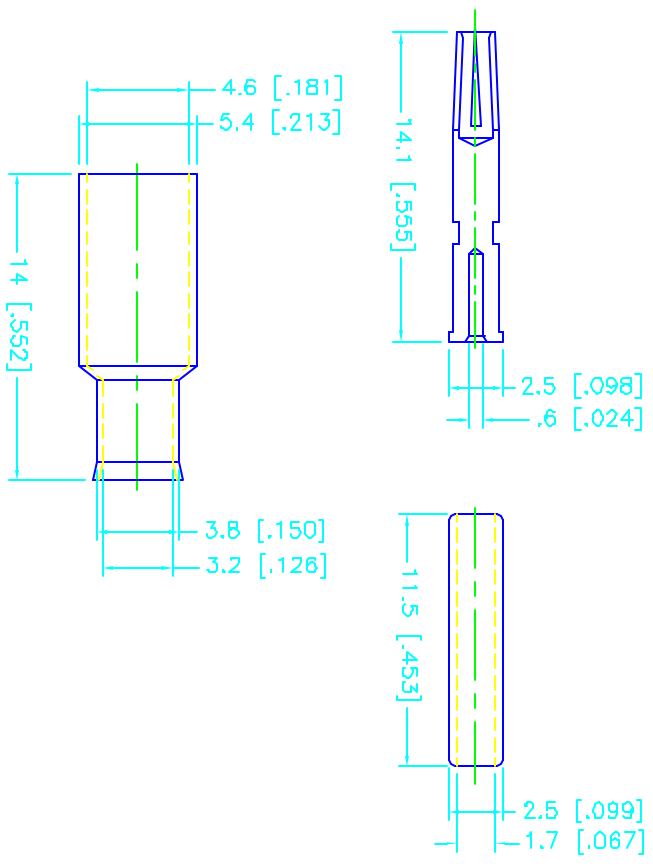
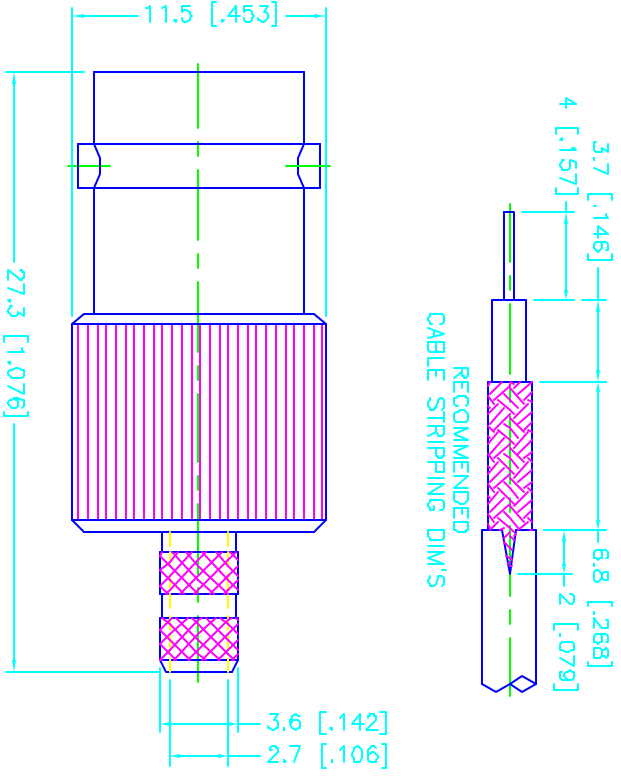

DESCRIPTION	MATERIAL	FINISH	UNLESS OTHERWISE SPECIFIED DIMENSIONS ARE IN MILLIMETERS FOR CUSTOMER REFERENCE ONLY	APPROVALS	DATE	TITLE	SCALE	PART NO.	SHEET
1 BODY	BRASS	NICKEL	UNLESS OTHERWISE SPECIFIED TOLERANCES FOR MILLIMETERS ARE: 0.5-6 ± 0.2 6-30 ± 0.4 30-120 ± 0.6 120-315 ± 1 315-1000 ± 1.6 1000-2000 ± 2.4	DRAWN	10/25/99	BNC STRAIGHT GRIMP JACK (FOR RG-316/U DOUBLE BRAID CABLE)	NA	99001	1 OF 1
2 INSULATOR	DELIRIN	NATURAL		CHECKED					
3 CONTACT PIN	PHOS. BRONZE	GOLD		ISSUED					
4 SLEEVE	DELIRIN	NATURAL							
5 FERRULE	BRASS	NICKEL							
6									
7									
8				DO NOT SCALE DRAWING					



Comnet Connector Corporation  
BNC STRAIGHT GRIMP JACK  
(FOR RG-316/U DOUBLE BRAID CABLE)

## Our Products

[7/16](#)  
[BNC](#)  
[D-Sub](#)  
[FME](#)  
[MCX](#)  
[MMCX](#)  
[SMA](#)  
[SMB](#)  
[SMC](#)  
[TNC](#)  
[Twin BNC](#)  
[Type F](#)  
[Type N](#)  
[UHF](#)

[Between-Series Adapters](#)  
[Shielded Terminations](#)  
[Strain-Relief Boots](#)  
[Tools](#)

[View All Products](#)

## BNC connector series

[Features & Benefits](#) | [Applications](#) | [50 Ω BNC Specs](#) | [75 Ω BNC Specs](#) | [Reverse Polarity Specs](#) | [Assembly Instructions](#)

Developed in the late 1940's as a miniature version of the Type C connector, BNC stands for Bayonet Neill Concelman and is named after Amphenol engineer Carl Concelman. The BNC product line is a miniature quick connect/disconnect RF connector. It features two bayonet lugs on the female connector; mating is achieved with only a quarter turn of the coupling nut. BNC's are ideally suited for cable termination for miniature to subminiature coaxial cable (RG-58, 59, to RG-179, RG-316, etc.)

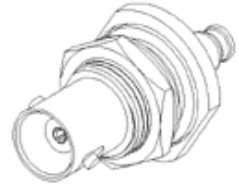

Amphenol 50 Ω BNC connectors are miniature, lightweight units designed to operate up to 11 GHz and typically yield low reflection through 4 GHz. Designed to accommodate a large variety of RG and industry standard cables, BNC connectors are available in crimp/crimp, clamp/solder, SURETWIST®, and field serviceable termination styles. A full line of printed circuit board receptacles, bulkhead receptacles, resistor terminations, and other accessories complement the product offering.

A variety of our 50 Ω BNC connectors are recognized under the Component program of Underwriter's Laboratories, Inc. These connectors are ideal for use with medical equipment and test instrumentation where safety cannot be compromised.

Amphenol also offers a full line of 75 Ω BNC connectors to meet the needs for higher performance impedance-matched cable interconnections. These connectors can be used in a variety of applications where true 75 Ω performance is needed to insure low signal distortion. Designed for the most popular 75 Ω cables used in broadcast and CATV applications as well as for plenum and other cables, these connectors feature crimp-crimp cable affixment for quick and reliable installation.

Two distinct types of 75 Ω BNCs are available, and both mate with each other and with 50 Ω BNCs. Type 1 is designated 75 Ω BNC-T1 and provides constant 75 Ω performance with low VSWR DC – 4 GHz. Type 2 is designated 75 Ω BNC-T2 and is usable with low reflection DC - 1 GHz. For applications above 1 GHz, Type 1 is recommended.

Part numbers that are listed with the appropriate M39012 number are military grade connectors produced in accordance with and actively qualified to the military specification MIL-C-39012. Connectors not listed with the M39012 number constitute the industrial grade product offering. These connectors provide comparable performance and generally feature nickel-plated brass bodies, Teflon insulators, and either gold or silver-plated center contacts. Amphenol's commercial grade connector offering carries the part number designation "RFX" for easy recognition. These low-cost connectors typically utilize die cast and molded components. While performance will not be equal to the industrial or military grade products, these connectors are ideal for use on a variety of commercial applications.

Reverse Polarity BNCs are also available. Reverse polarity is a keying system accomplished with a reverse interface, and ensures that reverse polarity interface connectors do not mate with standard interface connectors. Amphenol accomplishes this by inserting female contacts into plugs and male contacts into jacks. Other manufacturers may use reverse threading to accomplish reverse polarity keying.

### BNC Coaxial Connectors

#### PLUG CRIMP ATTACHMENTS FOR FLEXIBLE CABLE

[Straight Crimp Plug - Captive Contact - Standard Cable](#)  
[Straight Solder Plug - Semi-Rigid Cable](#)  
[Straight Crimp Plug - Captive Contact - Miniature Cable](#)  
[Straight Crimp Plug - Captive Contact - Plenum Cable](#)  
[Straight Crimp Plug - Pin-In-Pin - Miniature Cable](#)  
[Straight Crimp Plug - Miniature Cable](#)  
[Straight Crimp Plug - Single Crimp](#)

#### RIGHT ANGLE PLUG CRIMP ATTACHMENTS FOR FLEXIBLE CABLE

[Right Angle Crimp/Solder Plug - Standard Cable](#)  
[Right Angle Crimp/Solder Plug - Plenum Cable](#)  
[Right Angle Crimp/Solder Plug - Miniature Cable](#)

- [Straight PCB Mount Jack - Three Legs](#)
- [Straight PCB Mount Jack](#)
- [Straight PCB Mount Jack](#)
- [Straight PCB Mount Jack](#)
- [Straight PCB Edge Mount Jack - End Launch](#)
- [Bulkhead Vertical PCB Receptacle - End Launch](#)
- [Commercial Straight PCB Mount Jack](#)
- [Commercial Straight PCB Mount Jack — Metal Body](#)
- [Commercial Right Angle PCB Mount Jack](#)
- [Commercial Right Angle PCB Mount Jack — Metal Body](#)

---

## BULKHEAD FEEDTHROUGH ADAPTERS

- [Jack-To-Jack Bulkhead Adapter](#)
- [Jack-To-Jack Bulkhead Adapter](#)
- [Jack-To-Jack Bulkhead Adapter](#)
- [Jack-To-Plug Bulkhead Adapter - Push-On](#)

---

## BULKHEAD ISOLATED GROUND ADAPTERS

- [Jack-To-Jack Bulkhead - Isolated Adapter](#)
- [Jack-To-Jack Bulkhead - Isolated Adapter](#)

---

## ADAPTERS

- [Jack-To-Jack Adapter](#)
- [Plug-To-Plug Adapter](#)
- [Right Angle Adapter - Plug-To-Jack](#)

---

## TEE ADAPTERS

- [Tee Adapter - Jack-To-Jack-To-Jack](#)
- [Tee Adapter - Jack-To-Plug-To-Jack](#)
- [Tee Adapter - Jack-To-Plug-To-Jack](#)
- [Tee Adapter - Jack-To-Jack-To-Plug](#)

---

## TERMINATORS

- [BNC Terminator Plug](#)
- [BNC Terminator Jack](#)

---

## ACCESSORIES

- [BNC Male Cap & Chain](#)
- [BNC Male Shorting Cap](#)

## Features & Benefits

- Bayonet coupling mechanism provides quick mating and unmating
- 50  $\Omega$  and 75  $\Omega$  impedance designs allow customers to match impedance to system requirements
- 50  $\Omega$  and 75  $\Omega$  connectors are intermateable to ensure non-destructive mating
- Three grades of connectors are available for military, industrial and commercial applications

## Applications

- |                            |                     |                    |
|----------------------------|---------------------|--------------------|
| ■ Antennas                 | ■ Automotive        | ■ Base Stations    |
| ■ Broadcast (75 $\Omega$ ) | ■ Cable Assemblies  | ■ Cable Modems     |
| ■ Components               | ■ Computers/LANs    | ■ Instrumentation  |
| ■ Oscilloscopes            | ■ Medical Equipment | ■ Mil-Aero         |
| ■ Radios                   | ■ Satcom            | ■ Surge Protection |
| ■ Telecom                  |                     |                    |

## 50 $\Omega$ BNC Specifications

<b>Electrical</b>	
Impedance	50 $\Omega$ nominal
Frequency Range	0-4 GHz with low reflection
Voltage Rating	500 volts peak

Dielectric Withstanding Voltage	1,500 volts rms
VSWR	M39012 straight connectors: 1.3 max 0-4 GHz M39012 right angle connectores: 1.35 max 0-4 GHz
MIL-C-39012 Contact Resistance	Center contact: 1.5 mΩ; Outer contact: 0.2 mΩ
MIL-C-39012 Insulation Resistance	5,000 MΩ
MIL-C 39012 Braid to Body	0.1 milliohm
MIL-C-39012 RF Leakage	-55 dB min at 3 GHz
MIL-C-39012 Insertion Loss	0.2 dB min at 3 GHz
<b>Mechanical</b>	
Mating	2-stud bayonet coupling per M39012
Braid/Jacket Cable Affixment	All crimps are hex braid; clamps are screw-thread nut and braid clamp
Center Conductor Cable Affixment	Crimps are crimp or solder; all other are solder only
Captivated Contacts	All crimps unless specified otherwise
Cable Retention	Crimps: 20-100 lbs; All others: 30-70 lbs
<b>Material</b>	
Male Contact	Brass
Female Contact	Beryllium copper or phosphorous bronze, silver or gold-plated
Other Metal Parts	Brass, nickel finish; M39012 is silver finish
Insulator	TFE, copolymer of styrene, glass-TFE (hermetically sealed)
Crimp Ferrule	Copper/brass
<b>Environmental</b>	
Temperature Range	TFE insulators: - 65°C to + 165 °C Copolymer of Styrene: - 55°C to + 85°C
Weatherproof	Clamps with clamp gaskets; crimps with heat-shrink tubing
Mermetic Seals	Pass helium leak test of $2 \times 10^{-8}$ cc/second
Shock	MIL-STD-202 method 202
Vibration	MIL-STD-202 method 202, test condition D
Moisture Resistance	MIL-STD-202 method 106
Corrosion	MIL-STD-202 method 101, test condition B
Temperature Cycling	MIL-STD-202 method 102, test condition D
Altitude	MIL-STD-202 method 105, test condition C
<b>Military</b>	
MIL-C-39012	Where applicable

Note: These characteristics are typical but may not apply to all connectors.

### 75 Ω BNC Specifications

<b>Electrical</b>	
Impedance	75Ω nominal
Frequency Range	0-4 GHz
Voltage Rating	500 volts rms
Dielectric Withstanding Voltage	1,500 volts rms
VSWR	Type 1: 1.5+0.1 f(GHz) DC to 4 GHz Type 2: 1.00+0.25 f(GHz) DC to 1 GHz
<b>Mechanical</b>	
Mating	2-stud bayonet lock
Cable Affixment	Crimp-crimp
<b>Material</b>	
Body, Coupling Sleeve, Male Contact	Brass
Female Contact	Beryllium copper or phosphorous bronze
Crimp Ferrule	Copper alloy
Contact Plating	Gold
Insulator	TFE, copolymer of styrene, glass-TFE (hermetically sealed)

Other Metal Parts Plating	Nickel
<b>Environmental</b>	
Temperature Range	TFE insulators: - 65°C to + 165 °C Copolymer of Styrene: - 55°C to + 85°C
Weatherproof	Clamps with clamp gaskets; crimps with heat-shrink tubing
Mermetic Seals	Pass helium leak test of $2 \times 10^{-8}$ cc/second
Shock	MIL-STD-202 method 202
Vibration	MIL-STD-202 method 204, test condition D
Moisture Resistance	MIL-STD-202 method 106
Corrosion	MIL-STD-202 method 101, test condition B
Temperature Cycling	MIL-STD-202 method 102, test condition D
Altitude	MIL-STD-202 method 105, test condition C

Note: These characteristics are typical but may not apply to all connectors.

### Reverse Polarity BNC Specifications

<b>Electrical</b>	
Impedance	50 $\Omega$
Frequency Range	0-4 GHz
Voltage Rating	500 volts peak
Dielectric Withstanding Voltage	1,500 volts rms
VSWR	M39012 straight connectors: 1.3 max @ 0-4 GHz M39012 right angle connectors: 1.35 max @ 0-4 GHz
Insertion Loss	0.18 dB @ 9 GHz
Insulation Resistance	$\geq 5,000$ M $\Omega$
<b>Mechanical</b>	
Mating	Bayonet coupling
Braid/Jacket Cable Affixment	Hex crimp
Center Conductor Cable Affixment	Hex crimp or solder
Captivated Contact	Except as noted
Cable Retention	20-100 lbs depending on cable
<b>Material</b>	
Male Cetner Contact	Brass, gold plated
Female Center Contact	Beryllium copper or phosphorous bronze, gold plated
Other Metal Parts	Brass with bright nickel finish
Insulators	TFE
Weatherproof Gaskets	Silicone rubber
<b>Environmental</b>	
Temperature Range	- 65°C to + 165 °C
Weatherproof	When mated with other Amphenol RP-BNC connectors
Corrosion	MIL-STD-202, method 101, test condition B

Note: These characteristics are typical but may not apply to all connectors.

 [back to top](#)